



## Global Power Electronics Company

**AD** **Advanced Drive Technology**  
motor control & power conversion

[www.adtech21.com](http://www.adtech21.com)

56 Beolmal-ro, Dongan-gu, Anyang-si, Gyeonggi-do, 14059, Korea

TEL : 82-31-459-5051 FAX : 82-31-459-5053

Specifications of the product are subject to change without notice for quality improvement.

Printed in Korea



# **iMASTER A1**

High Performance and Various applications  
Standard Drive





# iMASTER A1

High Performance and Various applications  
Standard Drive

## User Friendly Interface

LCD operator  
Schedule Operation  
Fieldbus Options

## Improved Performance and Torque

V/F Control  
Sensorless Vector Control  
Vector Control

## High Reliability

EMC Filter  
DC Choke  
Safety Function  
Certification

## Contents

Features	03
Product Type and Model Name	09
Specification	10
Connection Diagram	13
Main Terminal	14
Control Terminal	16
Operator Instruction	18
Peripheral Devices	21
Options	24
Dimension	25
Protective Functions	26
Applications	27

# Features

## ■ Strong torque performance

Stronger than or equal to competitors in terms of strong low-speed torque performance, high torque performance in all areas.

- ▶ Auto torque boost 200% 3Hz
- ▶ Sensorless vector control 200% 1Hz

### ● Auto Torque Boost (T-N Curve)

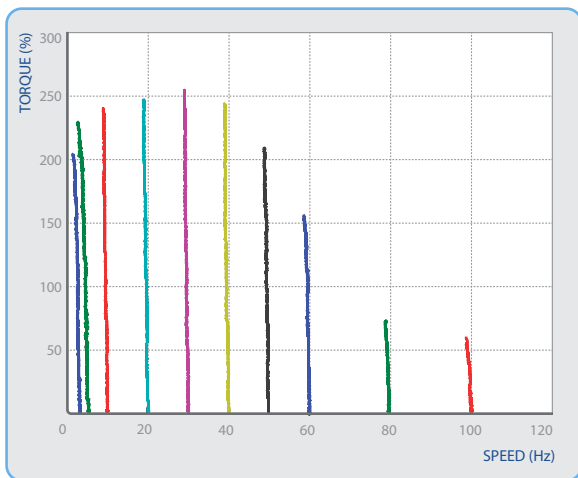

### ● Sensorless Vector Control (T-N Curve)

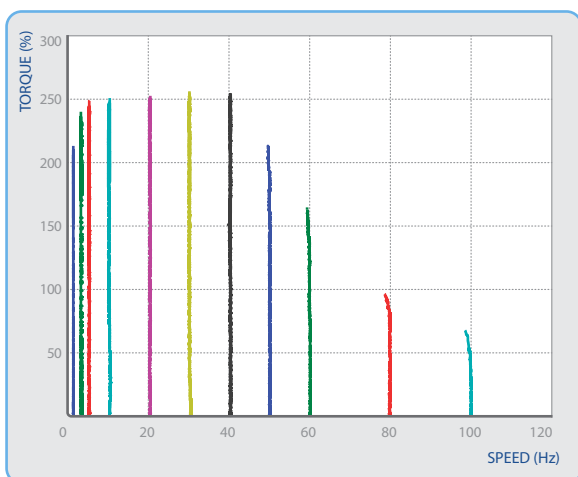

## ■ Instantaneous Interruption Energy Buffering Operation

When instantaneous interruption occurs, regeneration energy induced by load inertia is used to keep DC link voltage and go down motor speed. In this way, normal operation is made possible when power is on again.

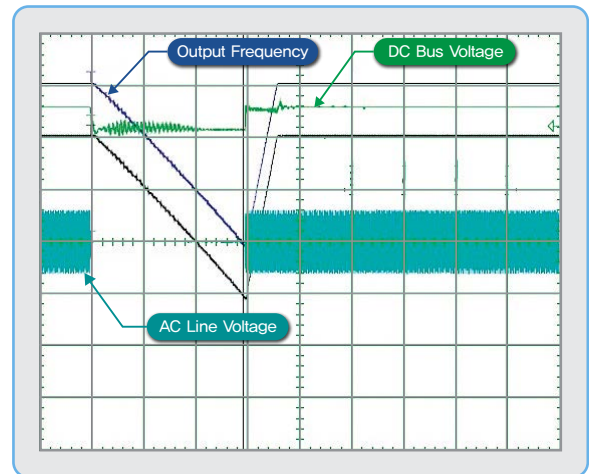

## ■ Droop Control

To drive the same load, the product responds to the torque change in each of multiple motors to control a speed and to enable each motor to keep an even load.

- Load balancing by droop control

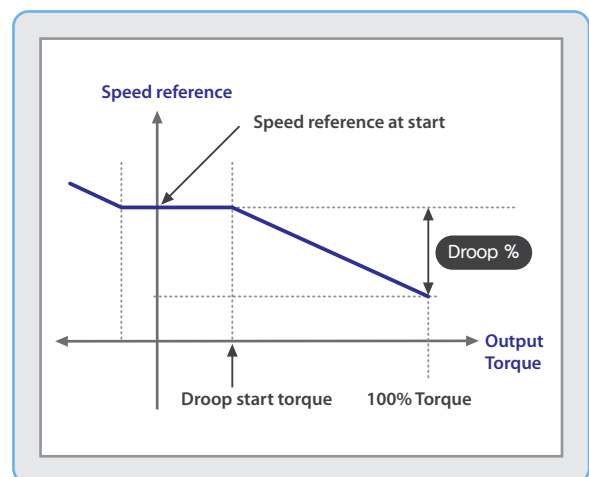

### Overcurrent Limit Performance

Even in the case of step load, it is possible to control output current smoothly and keep output frequency constantly.

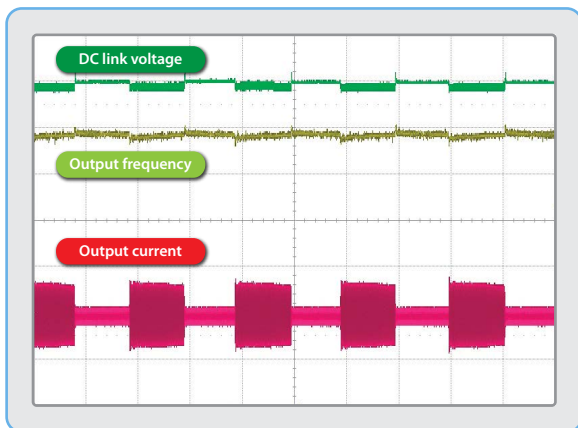

### PLC Function

PLC program runs for repeated operation from beginning step to last step in accordance with work procedure. Through simple input/output sequence control, it is possible to run without any external device.

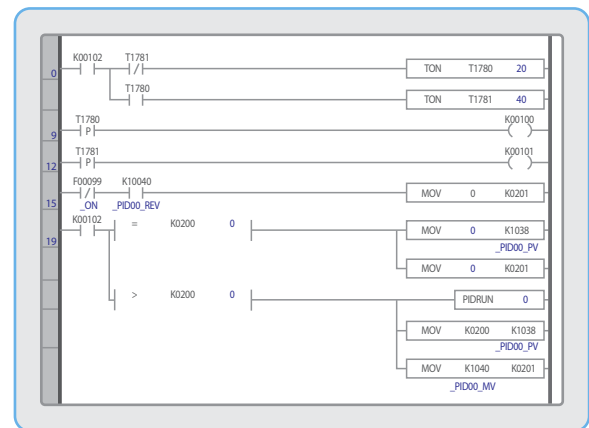

### Overvoltage Limit Performance (regeneration avoidance)

In the case of regular occurrence of regeneration load, it is possible to increase the output frequency of motor in regeneration zone and control DC link voltage rise.

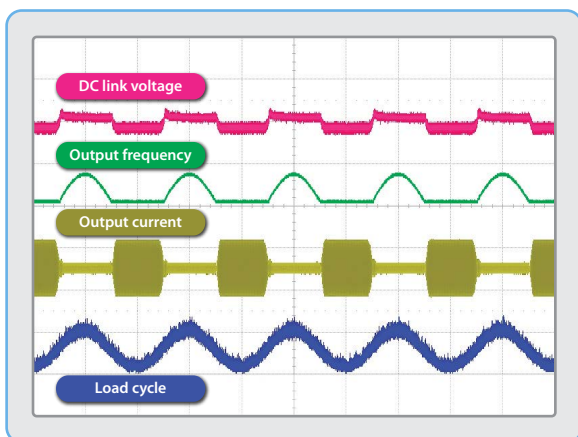

### PID Control

The automatic control function 'PID control' makes it possible to adjust proportional, integral, and differential gains so as to implement flexible and precise control. It is applied to compressor, hydraulic pump, and other feedback systems.

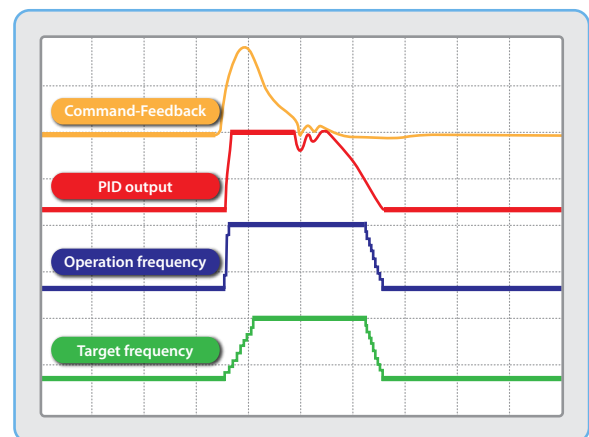

# Features

## ■ LCD Operator

Graphic LCD supports various information display on the screen and easy to use the button for operation.

- Multi-language support
- Schedule operation through timer (RTC)
- Connect to PC by USB port

\* LED Operator (Option)



LCD (English)



LCD (Korean)



LED

Symbol	Name	Function
← / PRG	Multi-function	Move to previous screen / Cancel at setting mode
→ / SET	Setting	Select parameters / Save the value of parameter
⬅️ ➡️ ⬆️ ⬇️	4 way key	Move to display or group / Move the position of cursor
L/R	Local / Remote	Change local or remote mode
DIR	Direction	Switch rotating direction of motor
STOP / RESET	Stop / Reset	Stop drive at local mode / Fault reset
RUN	Start	Start drive at local mode

Fieldbus Option

- Built in RS-485 1 port
- Ethernet Type– Modbus-TCP, Ethernet/IP, Profinet-IO
- Serial Type - Profibus DP, DeviceNet

Ethernet Type



Serial (Profibus DP)



Serial (DeviceNet)



Extended I/O

- Extended Input/Output
- Analog Input 2ea, Digital Input 2ea
- Analog Output 2ea, Digital Output 2ea

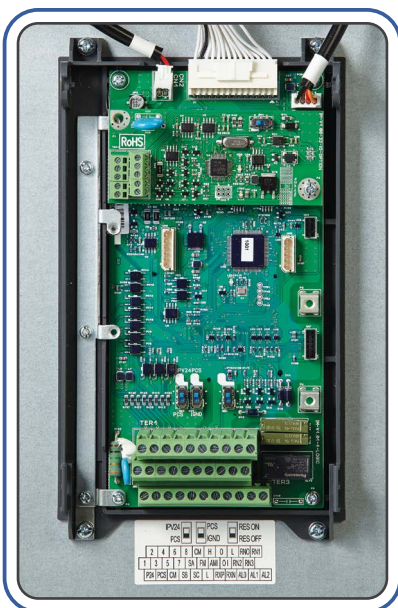

Encoder Option

- Encoder I/F (Vector Control)
- Open Collector/Line Drive Type
- Supply Voltage 5/12V

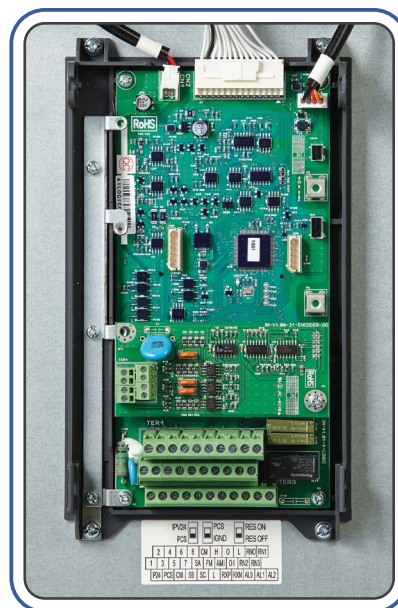



# Features

## ■ DC Choke

- Built-in DC Choke for 30~132kW drives
- Improve the operation reliability of connected external devices by reducing harmonics
- Connect the power source without AC reactor by improving the power factor

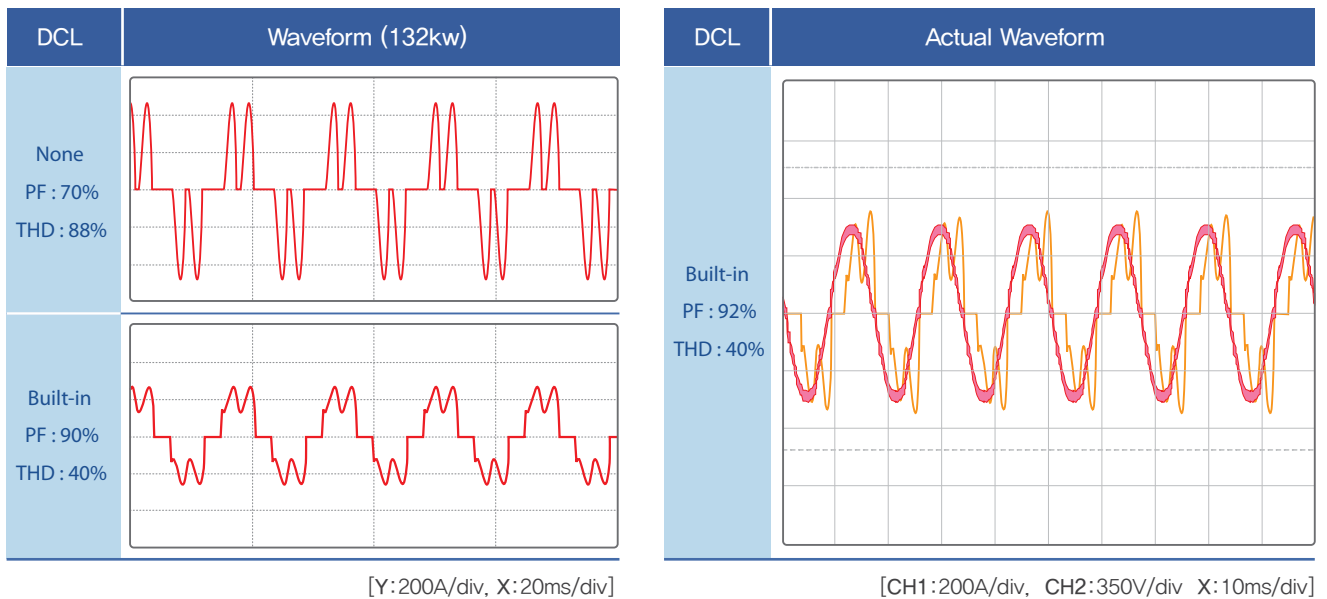

## ■ Built-in EMC Filter

- Built-in EMC filter to reduce the noise
- Standard 61800-3 C3 (Class A) – Conform CE certification

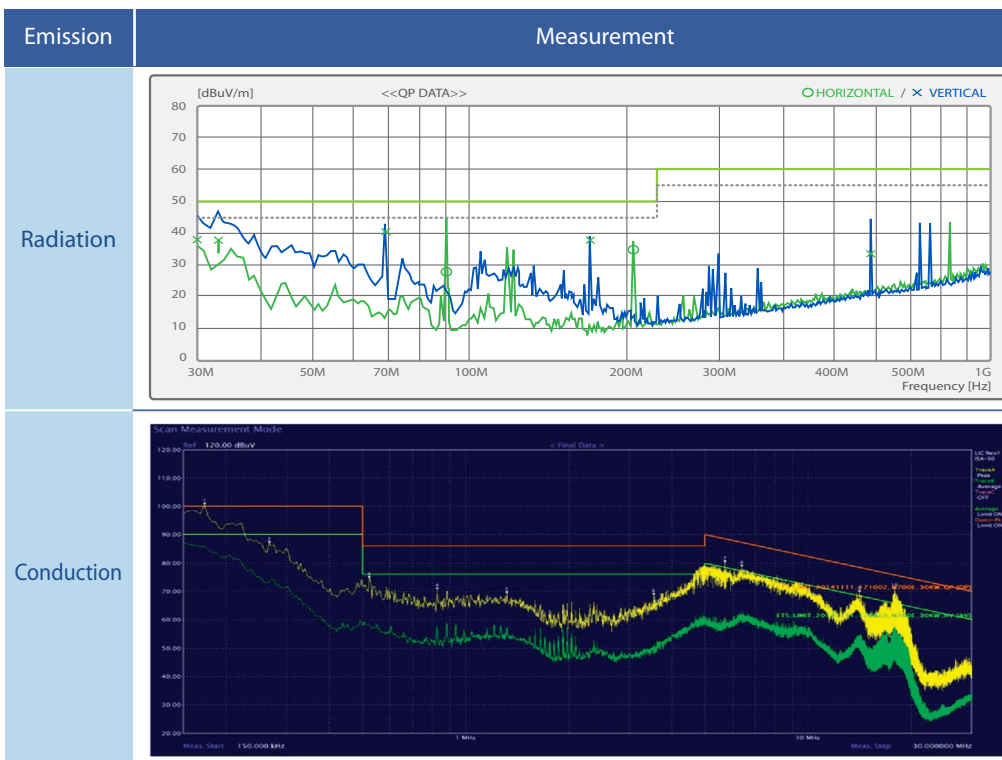

### ■ Safety Function

- Embedded safety function meets safety standards.
- Easy to fit the safety standard of system level by built-in safety function with conforms EN ISO 13849-1 PLd and EN 61508 SIL2 (EN60204-1)
- Safety function provides reliable protection, space-saving and cost reduction by removing external protection device.

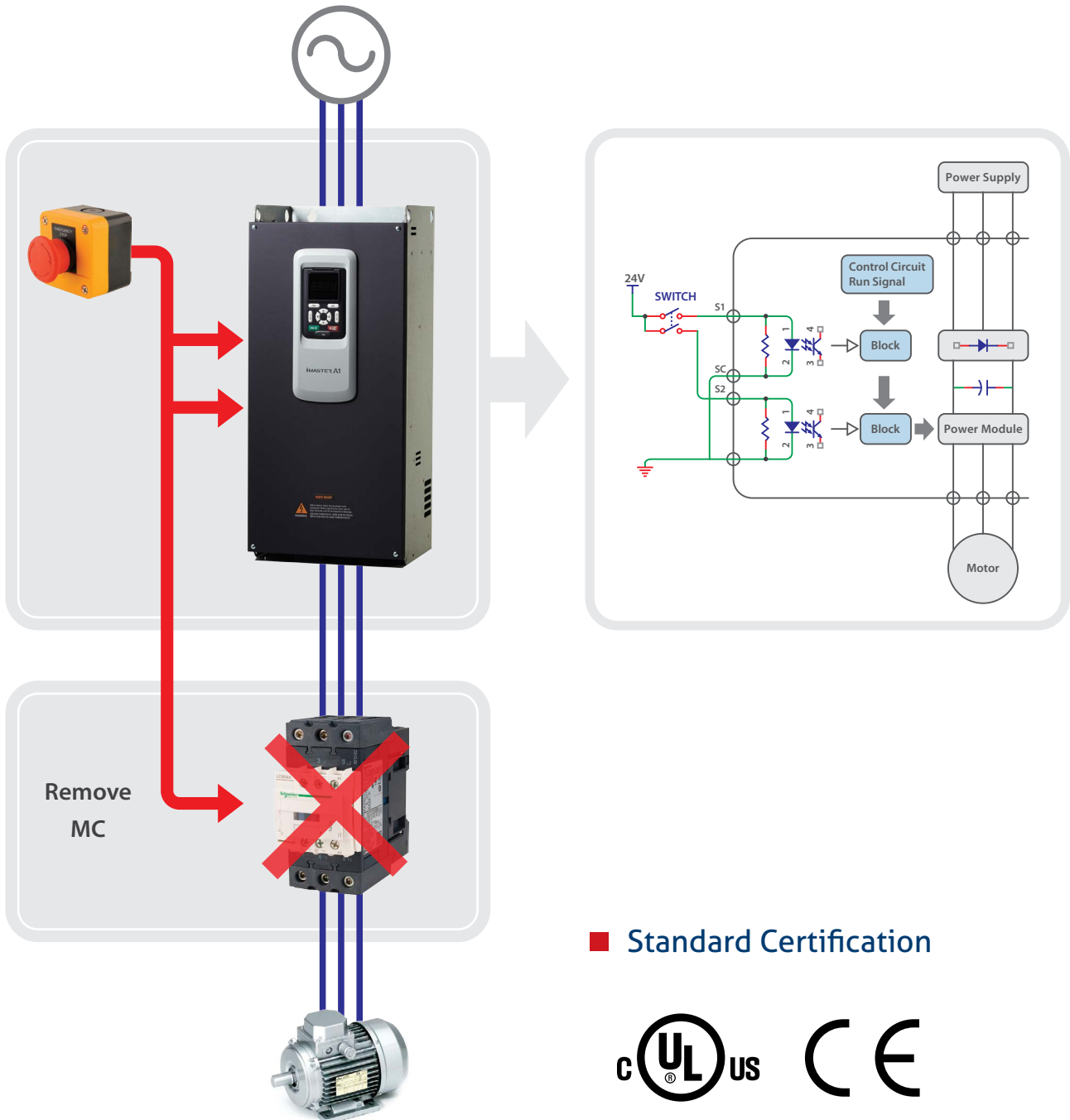

### ■ Standard Certification



# Product Type and Model Name

## ■ Product Type

Motor Capacity (kW)	3 Phase 200V				3 Phase 400V			
	Normal Duty		Heavy Duty		Normal Duty		Heavy Duty	
	Model	FLA	Model	FLA	Model	FLA	Model	FLA
5.5			A1-032A-□	24A			A1-016A-□	12A
7.5	A1-032A-□	32A	A1-045A-□	32A	A1-016A-□	16A	A1-023A-□	16A
11	A1-045A-□	45A	A1-064A-□	45A	A1-023A-□	23A	A1-032A-□	23A
15	A1-064A-□	64A	A1-076A-□	64A	A1-032A-□	32A	A1-038A-□	32A
18.5	A1-076A-□	76A	A1-090A-□	76A	A1-038A-□	38A	A1-045A-□	38A
22	A1-090A-□	90A	A1-114A-□	90A	A1-045A-□	45A	A1-058A-□	45A
30	A1-114A-□	114A	A1-140A-□	114A	A1-058A-□	58A	A1-075A-□	58A
37	A1-140A-□	140A	A1-170A-□	140A	A1-075A-□	75A	A1-090A-□	75A
45	A1-170A-□	170A	A1-205A-□	170A	A1-090A-□	90A	A1-110A-□	90A
55	A1-205A-□	205A	A1-261A-□	211A	A1-110A-□	110A	A1-149A-□	110A
75	A1-261A-□	261A	A1-310A-□	261A	A1-149A-□	149A	A1-176A-□	149A
90	A1-310A-□	310A			A1-176A-□	176A	A1-217A-□	176A
110					A1-217A-□	217A	A1-260A-□	217A
132					A1-260A-□	260A	A1-296A-□	260A
160					A1-296A-□	296A		

## ■ Model Name

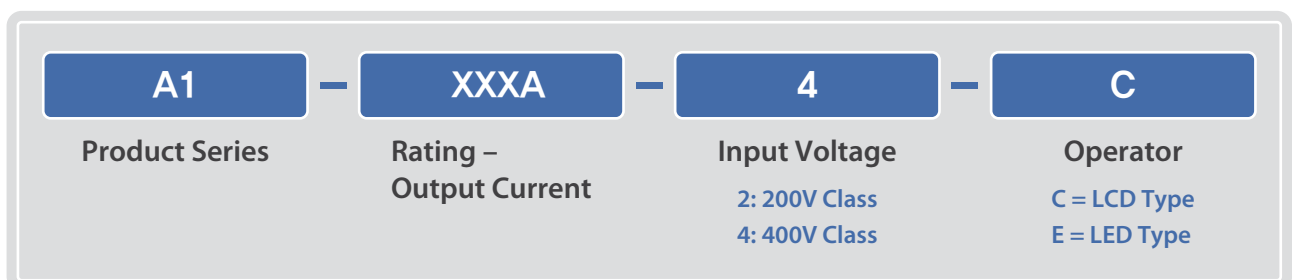

■ Input Voltage 200V Class

Model Name (A1-□ □ □ A-2)		032	045	064	076	090	114		
Applicable Motor *1) [HP]	HD	7.5	10	15	20	25	30		
	ND	10	15	20	25	30	40		
Applicable Motor *1) [kW]	HD	5.5	7.5	11	15	18.5	22		
	ND	7.5	11	15	18.5	22	30		
Rated Output	Current [A]		HD	24	32	45	64	76	90
			ND	32	45	64	76	90	114
	Capacity [kVA]	HD	200V	8	11	16	22	26	31
			240V	10	13	19	27	32	37
		ND	200V	11	16	22	26	31	39
			240V	13	19	27	32	37	47
Frequency [Hz]		0~400 Hz							
Voltage *2) [V]		3Φ 200~240V							
Rated Input	Available Voltage [V]		3Φ 200~240V (±10%)						
	Frequency [Hz]		50/ 60Hz (±5%)						
	Current *3) [A]	HD	20	28	40	55	68	81	
		ND	28	40	55	68	81	110	
	Power Loss [kW]	HD	0.11	0.15	0.22	0.3	0.37	0.44	
		ND	0.15	0.22	0.3	0.37	0.44	0.6	
FRAME		F1	F1	F1	F2	F2	F3		

- \*1) Motor capacity(kW,HP) is based on standard 220V 4 pole 60Hz motor.  
Drive's output current should be bigger than the rated current of motor or same as that of motor.
- \*2) Maximum output voltage dose not go over the supplied power voltage.
- \*3) Rated input current is based on 220V input voltage.

■ Input Voltage 200V Class

Model Name (A1-□ □ □ A-2)		140	170	205	261	310		
Applicable Motor *1) [HP]	HD	40	50	60	75	100		
	ND	50	60	75	100	125		
Applicable Motor *1) [kW]	HD	30	37	45	55	75		
	ND	37	45	55	75	90		
Rated Output	Current [A]		HD	114	140	170	211	261
			ND	140	170	205	261	310
	Capacity [kVA]	HD	200V	39	48	59	71	90
			240V	47	58	71	88	108
		ND	200V	48	59	71	90	107
			240V	58	71	85	108	129
Frequency [Hz]		0~400 Hz						
Voltage *2) [V]		3Φ 200~240V						
Rated Input	Available Voltage [V]		3Φ 200~240V (±10%)					
	Frequency [Hz]		50/ 60Hz (±5%)					
	Current *3) [A]	HD	102	126	154	187	257	
		ND	126	154	188	257	308	
	Power Loss [kW]	HD	0.60	0.74	0.90	1.10	1.50	
		ND	0.74	0.90	1.10	1.50	1.80	
FRAME		F3	F4	F4	F5	F5		

- \*1) Motor capacity(kW,HP) is based on standard 220V 4 pole 60Hz motor.  
Drive's output current should be bigger than the rated current of motor or same as that of motor.
- \*2) Maximum output voltage dose not go over the supplied power voltage.
- \*3) Rated input current is based on 220V input voltage.

# Specification

## Input Voltage 400V Class

Model Name (A1-□ □ □ A-4)		016	023	032	038	045	058		
Applicable Motor *1) [HP]	HD	7.5	10	15	20	25	30		
	ND	10	15	20	25	30	40		
Applicable Motor *1) [kW]	HD	5.5	7.5	11	15	18.5	22		
	ND	7.5	11	15	18.5	22	30		
Rated Output	Current [A]		HD	12	16	23	32	38	45
			ND	16	23	32	38	45	58
	Capacity [kVA]	HD	380V	8	11	15	21	25	30
			480V	10	13	19	27	32	37
		ND	380V	11	15	21	25	30	38
			480V	13	19	27	32	37	48
Frequency [Hz]		0~400 Hz							
Voltage *2) [V]		3Φ 380~480V							
Rated Input	Available Voltage [V]		3Φ 380~480V (±10%)						
	Frequency [Hz]		50/ 60Hz (±5%)						
	Current *3) [A]	HD	10	14	20	28	34	40	
		ND	14	20	28	34	40	55	
	Power Loss [kW]	HD	0.11	0.15	0.22	0.3	0.37	0.44	
		ND	0.15	0.22	0.3	0.37	0.44	0.6	
FRAME		F1	F1	F1	F2	F2	F2		

\*1) Motor capacity(kW,HP) is based on standard 440V 4 pole 60Hz motor.

Drive's output current should be bigger than the rated current of motor or same as that of motor.

\*2) Maximum output voltage dose not go over the supplied power voltage.

\*3) Rated input current is based on 440V input voltage.

## Input Voltage 400V Class

Model Name (A1-□ □ □ A-4)		075	090	110	149	176	217	260	296		
Applicable Motor *1) [HP]	HD	40	50	60	75	100	125	150	200		
	ND	50	60	75	100	125	150	200	250		
Applicable Motor *1) [kW]	HD	30	37	45	55	75	90	110	132		
	ND	37	45	55	75	90	110	132	160		
Rated Output	Current [A]		HD	58	75	90	110	149	176	217	260
			ND	75	90	110	149	176	217	260	296
	Capacity [kVA]	HD	380V	38	49	59	72	98	116	143	171
			480V	48	62	75	91	124	146	180	216
		ND	380V	49	59	72	98	116	143	171	195
			480V	62	75	91	124	146	180	216	246
Frequency [Hz]		0~400 Hz									
Voltage *2) [V]		3Φ 380~480V									
Rated Input	Available Voltage [V]		3Φ 380~480V (±10%)								
	Frequency [Hz]		50/ 60Hz (±5%)								
	Current *3) [A]	HD	59	73	89	109	149	178	218	262	
		ND	73	89	109	149	178	218	262	317	
	Power Loss [kW]	HD	0.60	0.74	0.90	1.10	1.50	1.80	2.20	2.64	
		ND	0.74	0.90	1.10	1.50	1.80	2.20	2.64	3.20	
FRAME		F3	F4	F4	F5	F5	F6	F6			

\*1) Motor capacity(kW,HP) is based on standard 440V 4 pole 60Hz motor.

Drive's output current should be bigger than the rated current of motor or same as that of motor.

\*2) Maximum output voltage dose not go over the supplied power voltage.

\*3) Rated input current is based on 440V input voltage.

■ Control

Item	Specification
Control Mode	V/f Control, Sensorless Vector Control, Vector Control
Frequency Setting Range	0.01 to 400Hz
Frequency Tolerance	Digital Reference : $\pm 0.01\%$ Analog Reference : $\pm 0.1\%$
Frequency Setting Resolution	Digital Command : 0.01 Hz Analog Command : 0.03 Hz / 60 Hz
Output Frequency Resolution	0.01 Hz
Frequency Setting	0~10 [V], 4~20 [mA], Operator
Carrier Frequency	1~10kHz (default ND:3kHz, HD:5kHz)
ACC/DEC Time	0.1~3000sec (linear, S curve, U curve)
Starting Torque	100% / 3 Hz (V/f) 200% / 1 Hz (SLV) 200% / 0 r/min (CLV)

Item	Specification	
Protective Function	Overcurrent	Exceeds internal over current trip level
	Overload	150%(HD) ,120%(ND) 60s
	Overvoltage	200V Class:410 V / 400V Class:820 V
	Low voltage	200V Class:190 V / 400V Class:380 V
	Heat sink overheat	NTC on IGBT
	Stall Prevention	Stall prevention during acceleration
	Ground Fault	Protection by electric circuit
Environment	Area of Use	Indoor
	Ambient Temperature	HD : -10 to 50°C / ND : -10 to 40°C
	Humidity	95% RH or less (no condensation)
	Storage Temperature	-20 to 60°C
	Altitude	Up to 1000 m
	Vibration	10Hz~20Hz 1G, 20Hz~55Hz 0.6G
Standard	UL 508C, EN61800-3 C3(2004/108/EC) EN61800-5-2, IEC6158:SIL 3	
Protective Design	Open IP00, NEMA Type 1 Enclosure	

# Connection Diagram

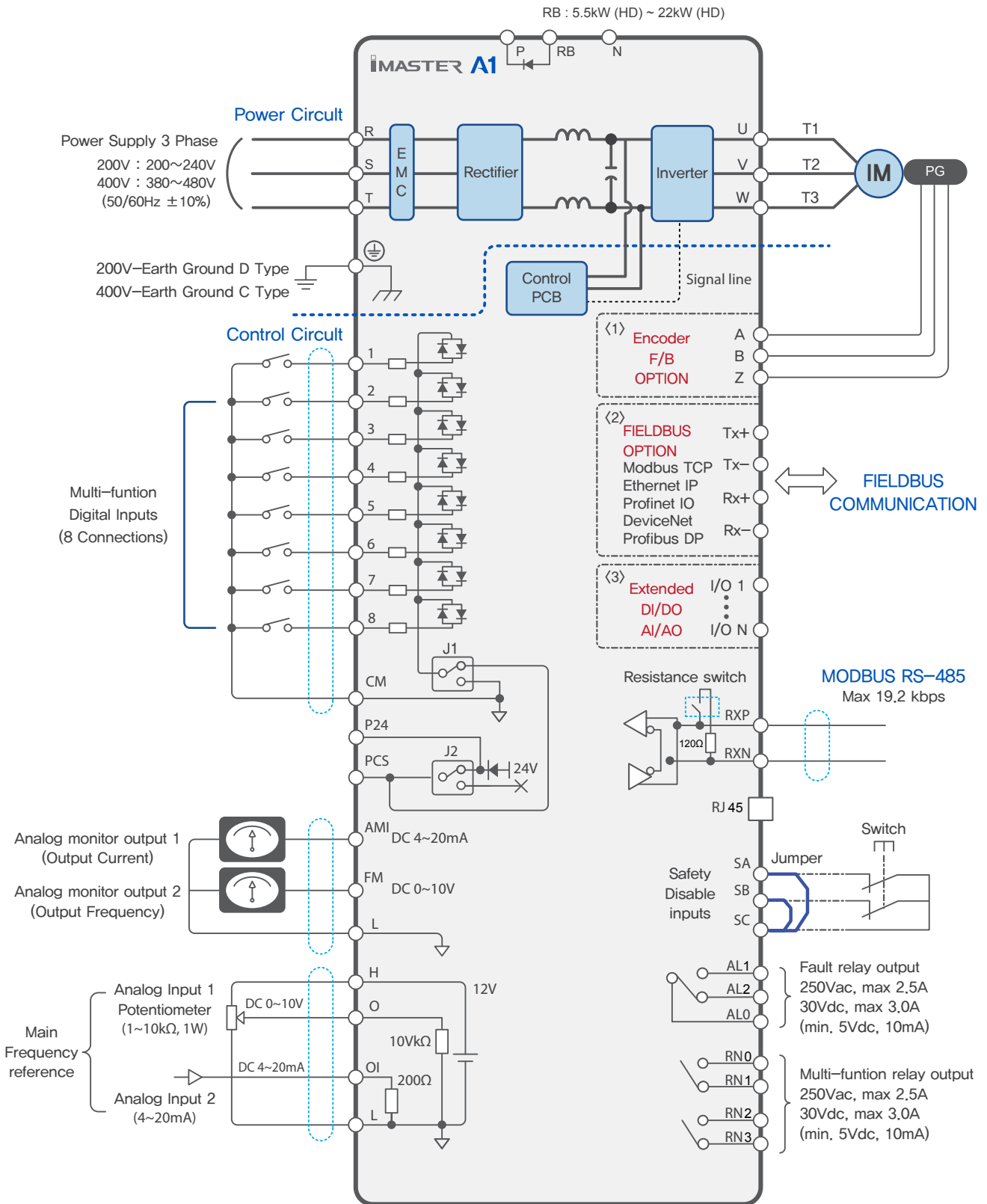

■ Using Dynamic Braking Unit(DBU)

P(+) terminal of drive connect to P(+) of DBU and N(-) terminal of drive connect to N(-) of DBU for use the DBU.

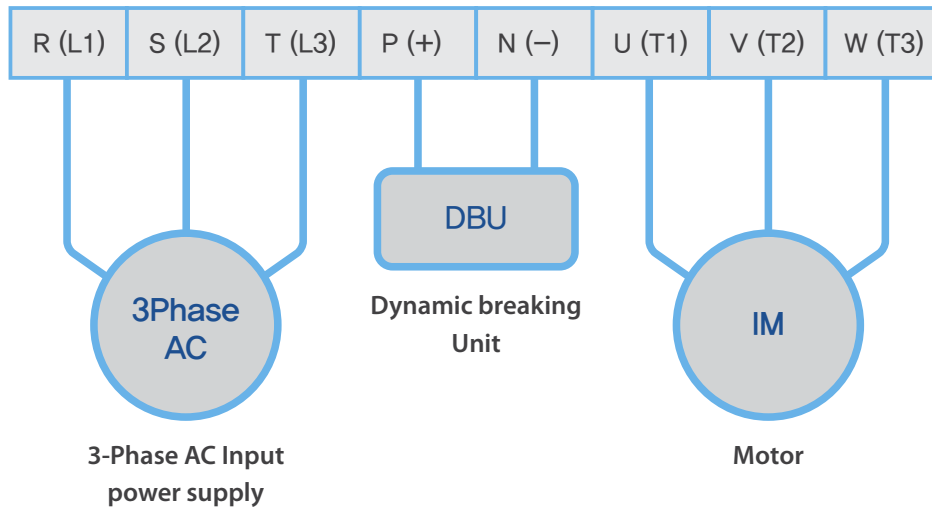

● 5.5~22kW Main Circuit Terminal

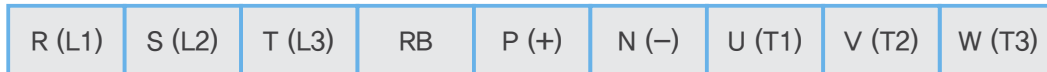

Terminal Name	In/Out	Functional Description	Specification
<b>Main Circuit Connection</b>			
R,S,T (L1, L2, L3) U,V,W (T1,T2,T3)	In Out	3 Phase 50/60 Hz / AC input power supply. 3 Phase PWM output power for motor	200 ~240V ±10% 380 ~480V ±10%
P,N		Optional External Braking Unit Connector. Recommend to use for 30~132 kW (40 ~ 250 HP) models	
RB		Braking Resistor connection for 5.5~22kW	
G		Ground Terminal	



# Main Terminal

## ■ Wiring Specification

Class	Motor Output (kW)	VFD Model	Power lines R,S,T, U,V,W,P,N			Screw Size of Terminal	Torque N·m (lb·in)	FUSE [A]
			AWG	kcmil	Lug width (mm/inch)			
200V Class	37	A1-140A-2	3*2P	(52.6)*2P	22/0.87	M8	0.80~1.20 (7.08~10.6)	FWH-350A
	45	A1-170A-2	2*2P	(66.4)*2P	22/0.87	M8	0.80~1.20 (7.08~10.6)	FWH-400A
	55	A1-205A-2	1*2P	(83.7)*2P	22/0.87	M8	0.80~1.20 (7.08~10.6)	FWH-400A
	75	A1-261A-2	2/0*2P	(133.1)*2P	27/1.06	M10	0.80~1.80 (7.08~15.9)	FWH-600A
	90	A1-310A-2	3/0*2P	(167.8)*2P	27/1.06	M10	0.80~1.80 (7.08~15.9)	FWH-700A
400V Class	37	A1-075A-4	2	66.4	16/0.63	M6	0.80~1.00 (7.08~8.85)	FWH-250A
	45	A1-090A-4	2	66.4	16/0.63	M6	0.80~1.00 (7.08~8.85)	FWH-250A
	55	A1-110A-4	1/0 or 4*2P	105.5 or (41.7)*2P	22/0.87	M8	0.80~1.20 (7.08~10.6)	FWH-250A
	75	A1-149A-4	3*2P	(52.6)*3P	22/0.87	M8	0.80~1.20 (7.08~10.6)	FWH-350A
	90	A1-176A-4	2*2P	(66.4)*2P	22/0.87	M8	0.80~1.20 (7.08~10.6)	FWH-400A
	110	A1-217A-4	1/0*2P	(105.5)*2P	22/0.87	M8	0.80~1.20 (7.08~10.6)	FWH-500A
	132	A1-260A-4	2/0*2P	(133.1)*2P	24/0.94	M10	0.80~1.80 (7.08~15.9)	FWH-600A
	160	A1-296A-4	3/0*2P	(167.8)*2P	27/1.06	M10	0.80~1.80 (7.08~15.9)	FWH-700A

Note 1) Bolt for terminal should be used to standard torque. If not tighten a screw, it is caused of malfunction

In case of using circuit breaker, the circuit breaker current select 1.5~2 times of drive rated current.

Fuse specification is 600V class and UL certification product, maker is Bussmann.

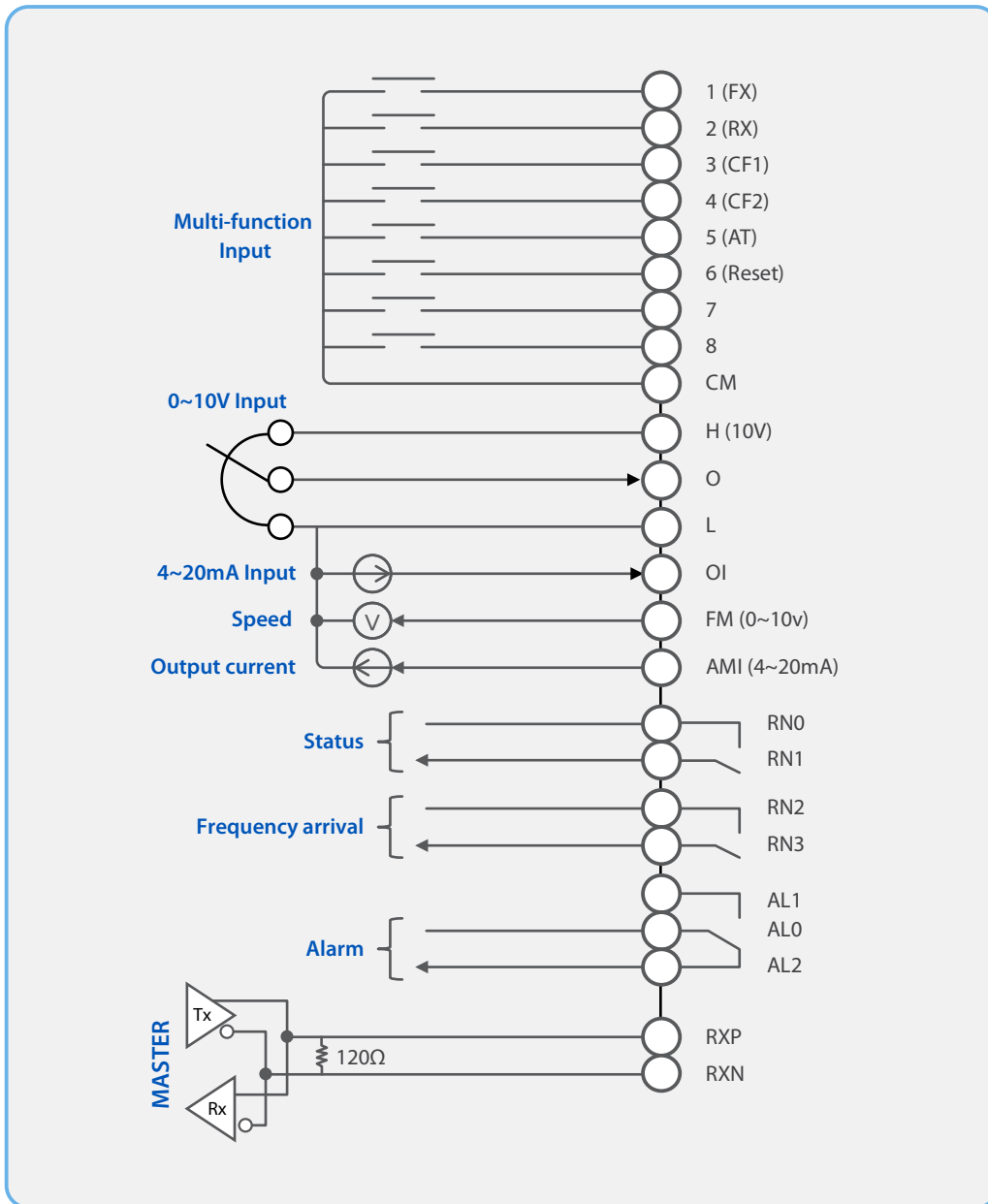

# Control Terminal

## ■ Control Terminal Description

Terminal Name	In/Out	Functional Description	Value
P24	OUT	Power Supply for external device (Always ON)	24VDC $\pm$ 7% P24+PCS = 300mA
PCS	OUT	Power Supply for external device such as PLC (Variable ON - OFF)	VDC $\pm$ 7%, P24+PCS = 300mA
<b>Multi function digital Input[1:8]</b>	IN	8 Bit Intelligent input terminal. By programming the respective terminal, can be used as command	Contact Closed : ON Contact Open : OFF Min ON Time : 12 ms
CM	IN/OUT	Common Terminal for Intelligent Input and Monitor Output	
AMI	OUT	Analog Current (4~20mA) Output	
FM	OUT	Analog Voltage (0~10V) Output	
L	OUT	DC Power Supply Common	
H (P12)	OUT	Power Supply for Potentiometer	12VDC
O	IN	Analog Voltage for Frequency Setpoint	0 ~ 10 VDC, Input Impedance 10 k $\Omega$
OI	IN	Analog Current for Frequency Setpoint	4~ 20mA, Input Impedance 200 $\Omega$
<b>ALO,AL1,AL2</b>	OUT	Intelligent output terminal: OUTPUT RELAY 1, 2 Run status signal(RUN), Frequency arrival signal(FA1), Set frequency arrival signal(FA2), Overload advance notice signal(OL), PID error deviation signal(OD), Alarm signal(AL)	AC 250V / 2.5A (resistor load) 0.2A (inductor load)  DC 30V / 3.0A (resistor load) 0.7A (resistor load)
<b>RN0,RN1 RN2,RN3</b>	OUT	Intelligent output terminal OUTPUT RELAY 3	
SA	IN	Safety Input terminal: One or both open: Drive output disabled	
SB		Both closed: Normal operation	
SC		Common terminal for Safety Input	
<b>Communication Connector</b>			
RXP	IN/OUT	RS 485 Positive Communication Terminal	
RXN	IN/OUT	RS 485 Negative Communication Terminal	



Symbol	Name	Function
—	Multi-function 1	Move to previous screen Cancel at setting mode Move to trip history view
—	Multi-function 2	Select parameters Save the value of parameter
◀ ▶ ▲ ▼	4 way key	Move to display or group Move the position of cursor
L/R	Local / Remote	Change local or remote mode
DIR	Direction	Change rotating direction of motor
STOP/RESET	Stop / Reset	Stop drive at local mode Fault reset
RUN	Start	Start drive at local mode

# Operator Instruction

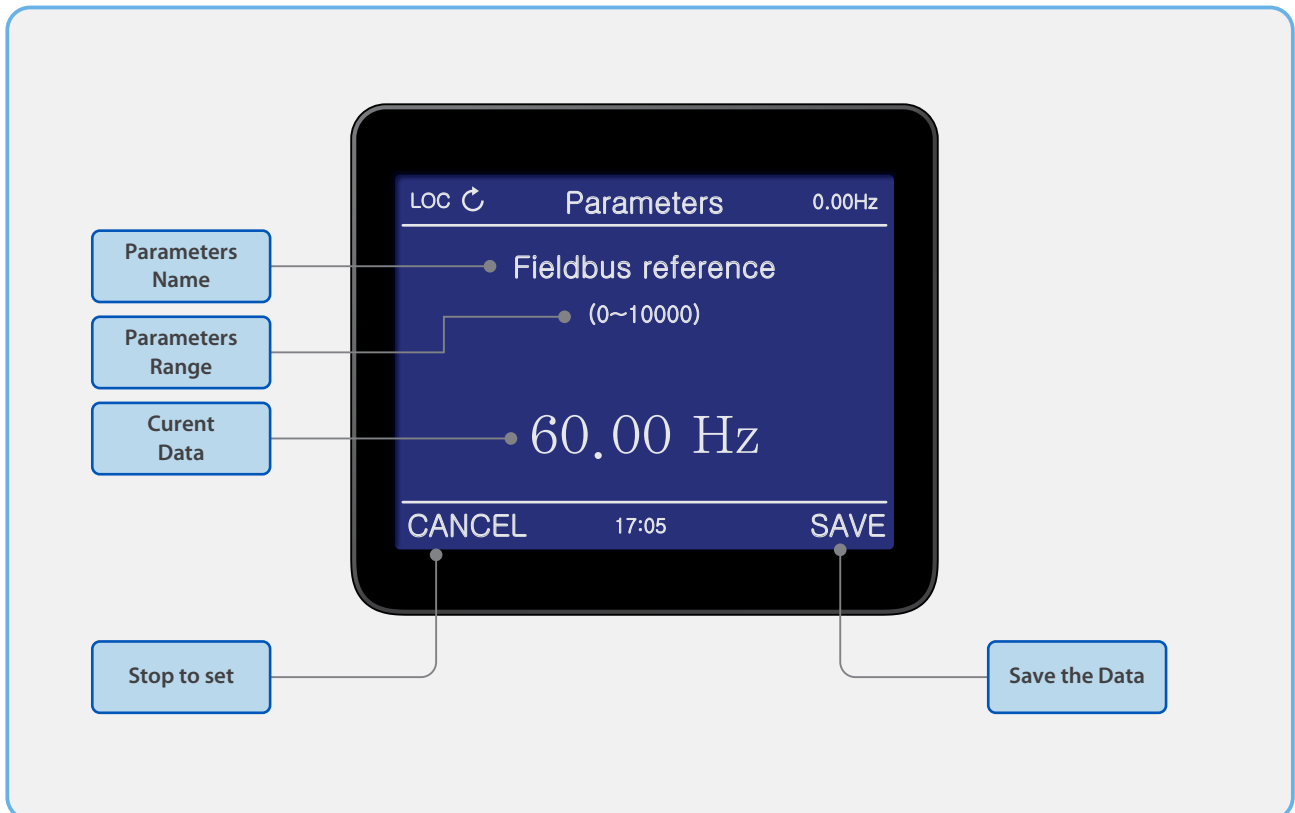
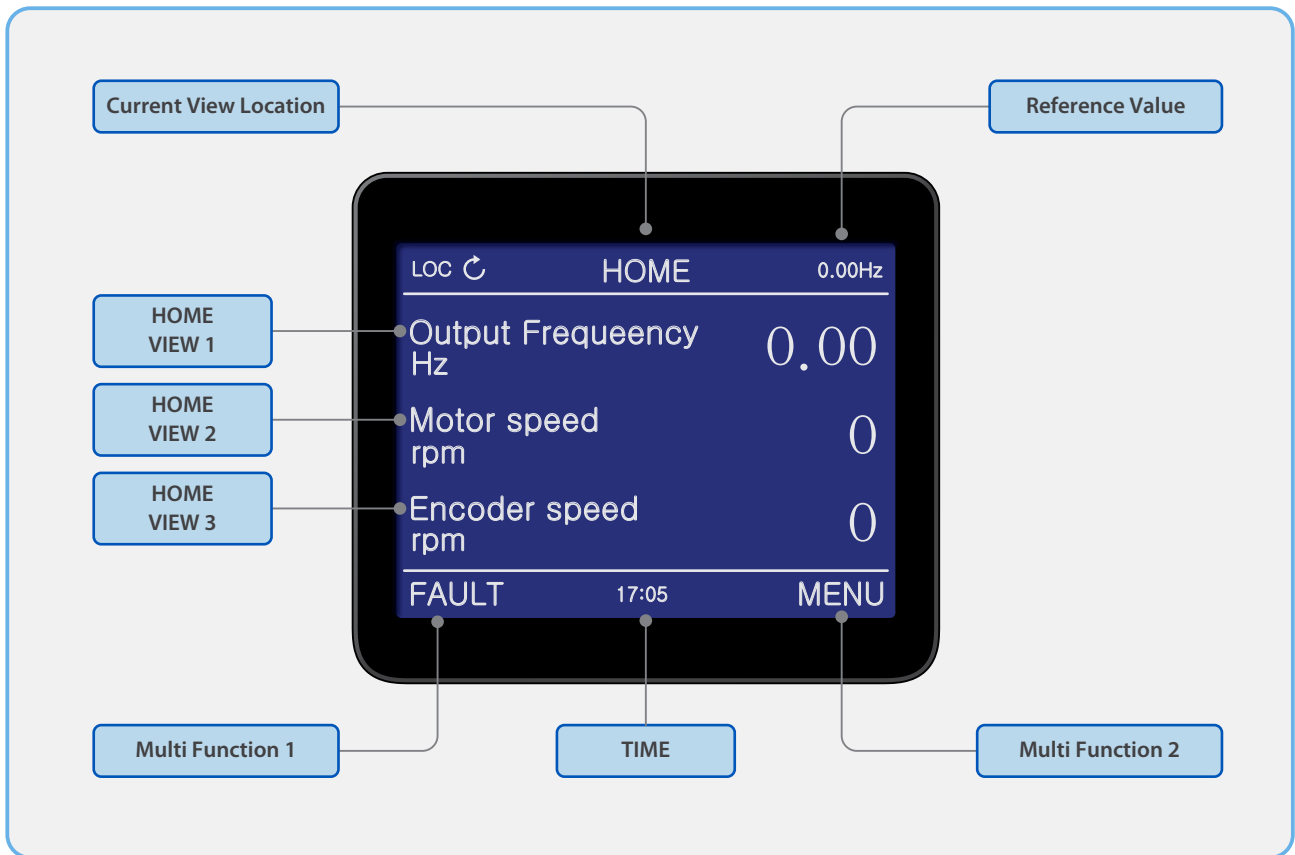

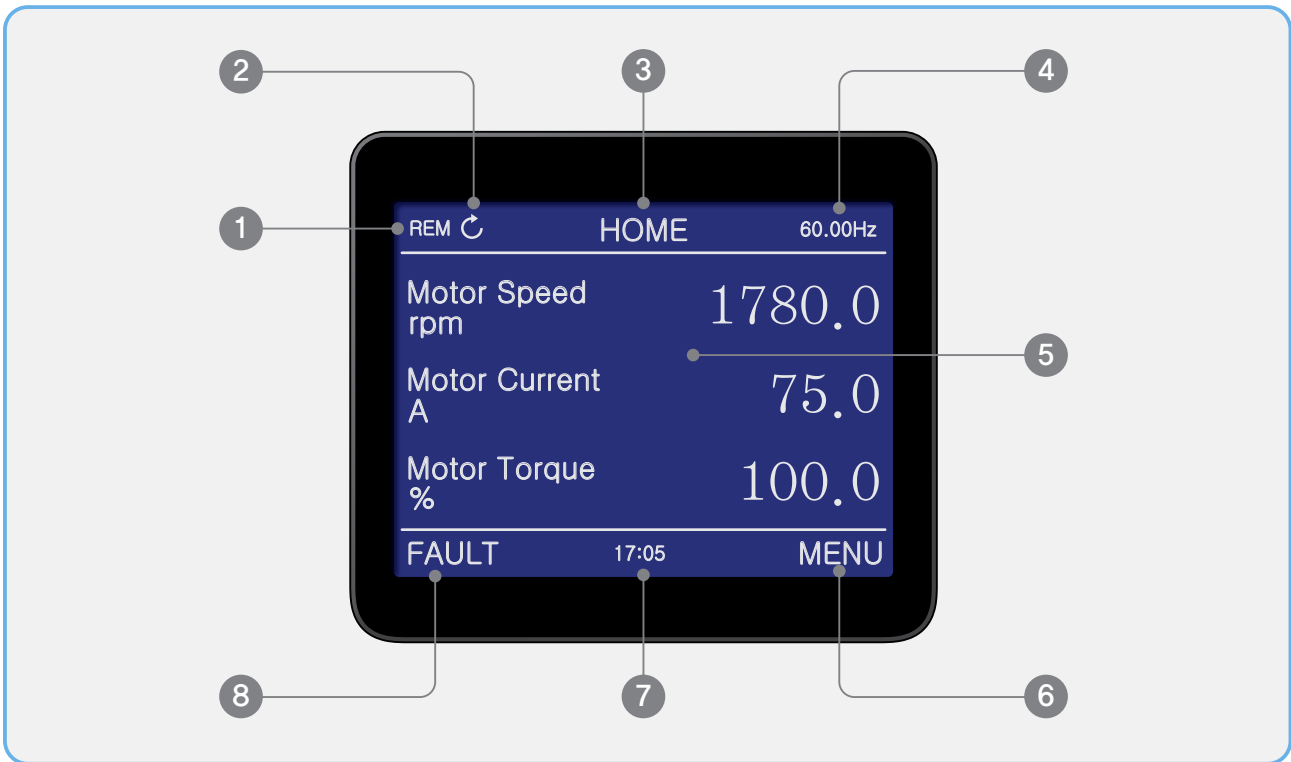

No	Function	Display	Description
1	Control location	LOC	VFD is controlled by VFD Keypad
		REM	VFD is controlled by terminal block
2	Running Status	↻ Rotation	VFD is stop
		↻ Rotation	VFD is running to forward
		↻ Rotation	VFD is running to reverse
		↻ Flickering	VFD is stopping from forward
		↻ Flickering	VFD is stopping from reverse
3	Current Status	Home	Home mode
		Menu	Menu mode
		Fault	Fault status
4	Reference Value	00.00Hz	Display referenced value
5	Current View	-	Display selected item
6	Multi Right Key	Menu	Move to menu view
		Select	Select the item
		Save	Save the parameter data
		Read	Read all parameters for copy
		Write	Write all parameters for copy
7	Time	00:00	Display the current time
8	Multi Left Key	Back	Move to previous view
		Cancel	Cancel at parameter view
		Fault	Move to fault view

# Peripheral Devices

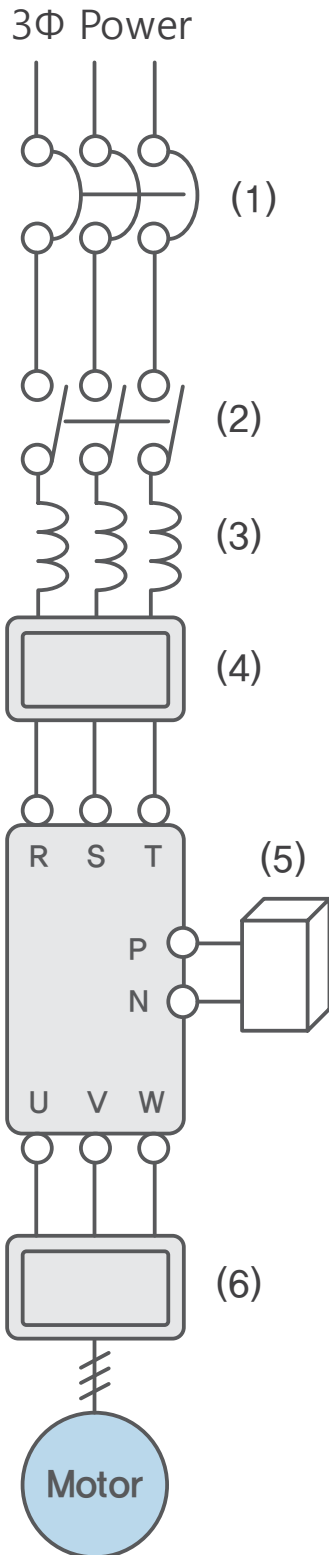

	Name	Function
1	<b>Molded case circuit breaker, or earth leakage circuit breaker</b>	When inverter is powered on, big inrush current flows. Therefore, be careful to choose circuit breaker.
2	<b>Electromagnetic contactor</b>	It is not always required to be installed. With this electromagnetic contactor, do not run or stop inverter frequently. Otherwise, inverter lifespan is shortened.
3	<b>AC reactor</b>	In the case of power factor improvement, or of the installation in the place with big input power capacity (more than 500kVA, more than 10-fold of inverter capacity, more than 3% of voltage unbalance, within 10m of wiring), it is required to apply the reactor. Be careful to choose one.
4	<b>Input noise filter</b>	This device reduces the noise emitted by input power line.
5	<b>Braking unit</b>	This device is used to increase inverter braking torque, or to turn ON/OFF highly frequently, or to operate big inertia moment (GD2) load.
6	<b>Output noise filter</b>	This device is installed in between inverter and motor, reducing the noise emitted by wire. In addition, it alleviates radio or TV signal troubles or prevents malfunction of sensors or measuring instruments.

■ AC Reactor

Voltage	Drive Model	Heavy Duty			Normal Duty		
		kW	mH	A	kW	mH	A
3Φ 200V	A1-032A-2	5.5	0.34	30	7.5	0.25	40
	A1-045A-2	7.5	0.25	40	11	0.17	59
	A1-064A-2	11	0.17	59	15	0.13	75
	A1-076A-2	15	0.13	75	18.5	0.11	96
	A1-090A-2	18.5	0.11	96	22	0.09	112
	A1-114A-2	22	0.09	112	30	0.06	160
	A1-140A-2	30	0.07	160	37	0.05	200
	A1-170A-2	37	0.05	200	45	0.044	240
	A1-205A-2	45	0.044	240	55	0.038	280
	A1-261A-2	55	0.038	280	75	0.026	360
A1-310A-2	75	0.026	360	90	0.02	500	
3Φ 400V	A1-016A-4	5.5	1.35	15	7.5	1.01	20
	A1-023A-4	7.5	1.01	20	11	0.67	30
	A1-032A-4	11	0.67	30	15	0.53	38
	A1-038A-4	15	0.53	38	18.5	0.40	50
	A1-045A-4	18.5	0.40	50	22	0.35	58
	A1-058A-4	22	0.35	58	30	0.25	80
	A1-075A-4	30	0.287	80	37	0.232	98
	A1-090A-4	37	0.232	98	45	0.195	118
	A1-110A-4	45	0.195	118	55	0.157	142
	A1-149A-4	55	0.157	142	75	0.122	196
	A1-176A-4	75	0.122	196	90	0.096	237
	A1-217A-4	90	0.096	237	110	0.081	289
	A1-260A-4	110	0.081	289	132	0.069	341
	A1-296A-4	132	0.069	341	160	0.057	420



# Peripheral Devices

## ■ Braking Resistor

200V Drive		150% Torque, 5% ED		400V Drive		150% Torque, 5% ED	
Model Name	kW	$\Omega$	W	Model Name	kW	$\Omega$	W
A1-032A-2	5.5	20	800	A1-016A-4	5.5	85	800
A1-045A-2	7.5	15	1200	A1-023A-4	7.5	60	1200
A1-064A-2	11	10	2400	A1-032A-4	11	40	2400
A1-076A-2	15	8	2400	A1-038A-4	15	30	2400
A1-090A-2	18.5	5	3600	A1-045A-4	18.5	20	3600
A1-114A-2	22	5	3600	A1-058A-4	22	20	3600

## ■ Dynamic Braking Unit

Voltage	Drive Model	kW	DBU Type	R [ $\Omega$ ]	Wattage [kW]	Specification
3 $\Phi$ 200V	A1-140A-2	30	FBU100-037-2	4.5	10	150% Braking Torque10% ED
	A1-170A-2	37		4.5	10	
	A1-205A-2	45	FBU100-075-2	2.5	10	
	A1-261A-2	55		2.5	20	
	A1-310A-2	75		2.5	20	
3 $\Phi$ 400V	A1-075A-4	30	FBU100-037-4	12	10	
	A1-090A-4	37		12	10	
	A1-110A-4	45	FBU100-075-4	6	10	
	A1-149A-4	55		6	20	
	A1-176A-4	75		6	20	
	A1-217A-4	90	FBU100-090-4	5	26	
	A1-260A-4	110	FBU100-132-4	3.4	40	
	A1-296A-4	132		3.4	40	

Device	Model	Specification
Encoder	A1-ENOC	Open Collector Type : 3 track(A,B,Z pulse) Voltage output for PG 12V 200mA
	A1-ENLD	Line Drive Type : 3 track(A,B,Z pulse) Voltage output for PG 5 or 12V 200mA
Extended I/O	A1-EIO	Extended Input/Output
LED Operator	A1-LEDOP	7 Segment Display Set speed, acceleration and parameters in drive.
LCD Operator	A1-LCDOP	GRAPIC LCD Display Set speed, acceleration and parameters in drive.
Fieldbus	A1-FB□	Fieldbus option □: Modbus TCP-T Ethernet/IP-E Profinet IO-P DeviceNet- D Profibus DP-B

# Dimension

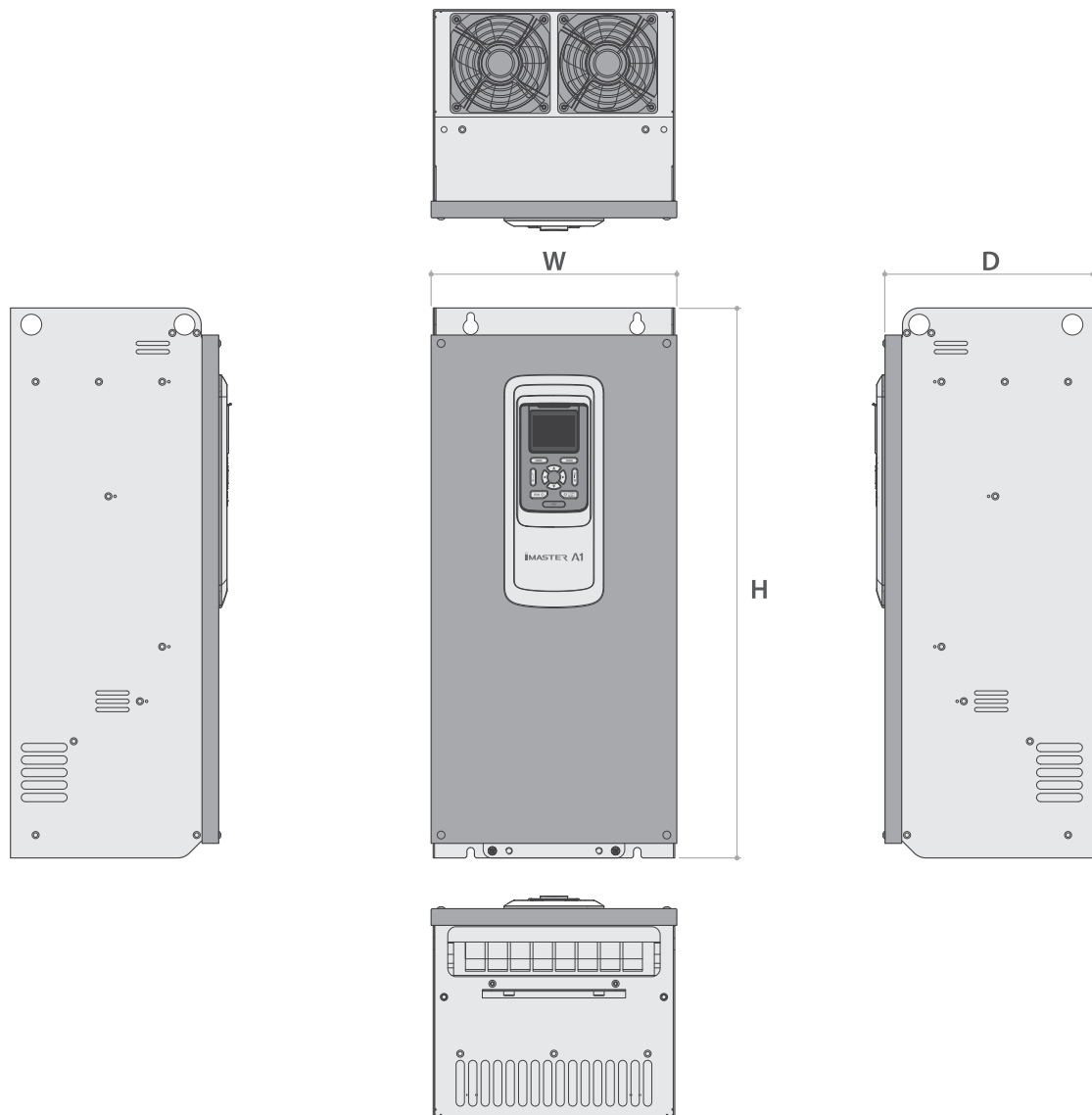

FRAME	Model	Dimension (mm)		
		W	H	D
F1	A1-032A-2 ~ A1-064A-2 A1-016A-4 ~ A1-032A-4	180	360	235
F2	A1-076A-2, A1-090A-2 A1-038A-4 ~ A1-058A-4	220	440	235
F3	A1-114A-2, A1-140A-2 A1-075A-4, A1-090A-4	270	550	265
F4	A1-170A-2, A1-205A-2 A1-110A-4, A1-149A-4	295	660	265
F5	A1-261A-2, A1-310A-2 A1-176A-4, A1-217A-4	345	760	275
F6	A1-260A-4, A1-296A-4	385	800	275

Type	Description	Sign
<b>Overcurrent</b>	If inverter output has short-circuit, or if motor stalls, overcurrent goes to inverter. As a result, protection circuit works and inverter output is blocked.	oC
<b>Output Short Circuit</b>	If inverter output has short-circuit, overcurrent occurs in inverter. As a result, protection circuit works and inverter output is blocked.	oC or SC
<b>Motor Overload</b>	If the motor output current detected is determined to be motor overload, the digital thermal device built in inverter detects it and blocks inverter output.	EtH
<b>Inverter Overload</b>	This is the function for protecting inverter overheat. In the case of basic carrier frequency, 150% and 1 minute on the basis of inverter rated current; depending on operation conditions, operation time changes. Operation time is different depending on inverter capacity.	IoLt
<b>Overvoltage</b>	If regeneration energy and receiving voltage from motor are high, or if load falls sharply in overload limitation, the voltage of converter part goes higher than a specific voltage. As a result, inverter output is blocked.	ov
<b>Low Voltage</b>	If input voltage goes down to less than a specific voltage, inverter works abnormally. Therefore, it goes down to the low voltage detection level, inverter output is blocked.	Lv
<b>EEPROM</b>	If external noise and temperature rise lead to abnormality of inverter built-in EEPROM (memory), output is blocked. Check setting data again, if error occurs. Alarm signal may not go out accurately. If alarm is not released by error in power-on state, power OFF. 10 minutes later, in the full discharge state, power ON.	E2PE
<b>Communication Error</b>	If communication problem occurs between inverter and operator, or between external communication devices, this error is displayed. (this error also occurs if Reset signal remains over 4 seconds.)	CE
<b>IGBT Over Temperature</b>	If the temperature of inverter module goes up more than a specific value, the internal temperature sensor detects it, and inverter output is blocked.	ot
<b>Input Phase Fail</b>	Inverter damage is prevented when one of input R, S, or T has phase fail.	PF
<b>Ground-fault</b>	Ground-fault of inverter output and motor is detected in operation, and thus inverter is protected.	GF
<b>USP Error</b>	If inverter is powered on in its RUN state in terminal mode, this error is displayed (in the case of USP function selection)	USP
<b>Cooling Fan Failure</b>	If cooling fan fails and does not rotate, inverter output is blocked.	FF
<b>OVS Control Failure</b>	If OVS(over voltage stress) operation frequency exceeds maximum OVS frequency and OVS operation time, inverter output is blocked.	ovSF
<b>External Event</b>	If any abnormality is found in external devices, inverter receives its signal and blocks output. (intelligent input terminal setting is required.)	EE1~EE5
<b>Safe Input Error</b>	If safe input terminal is opened, inverter output is blocked.	SAFE

# Applications

## ■ HVAC / Extruder

Diagram describe the speed reference by analog input, start and stop by terminal input, speed display by analog output, Status monitoring by RN output and alarm.

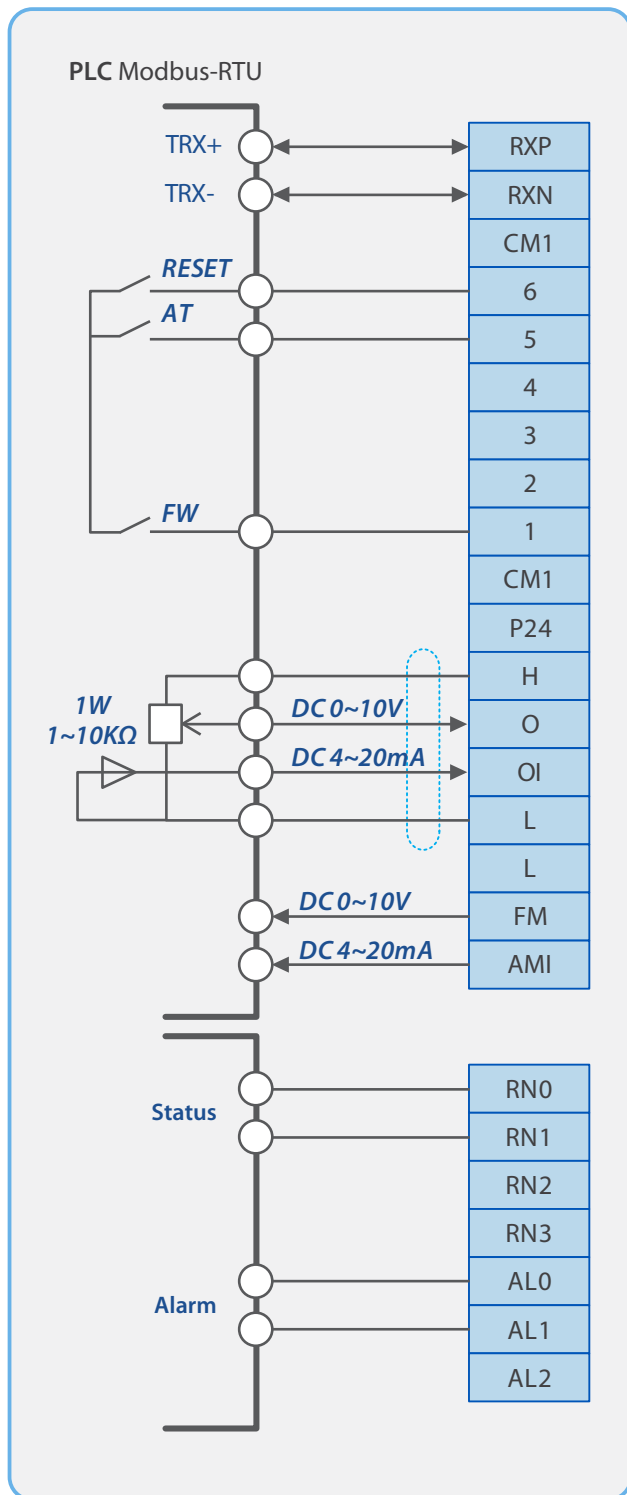

## ■ PID Compressor

Diagram describes the speed reference by analog input, the start and stop of drive by terminal input. PID control by feedback of current input from the pressure sensor.

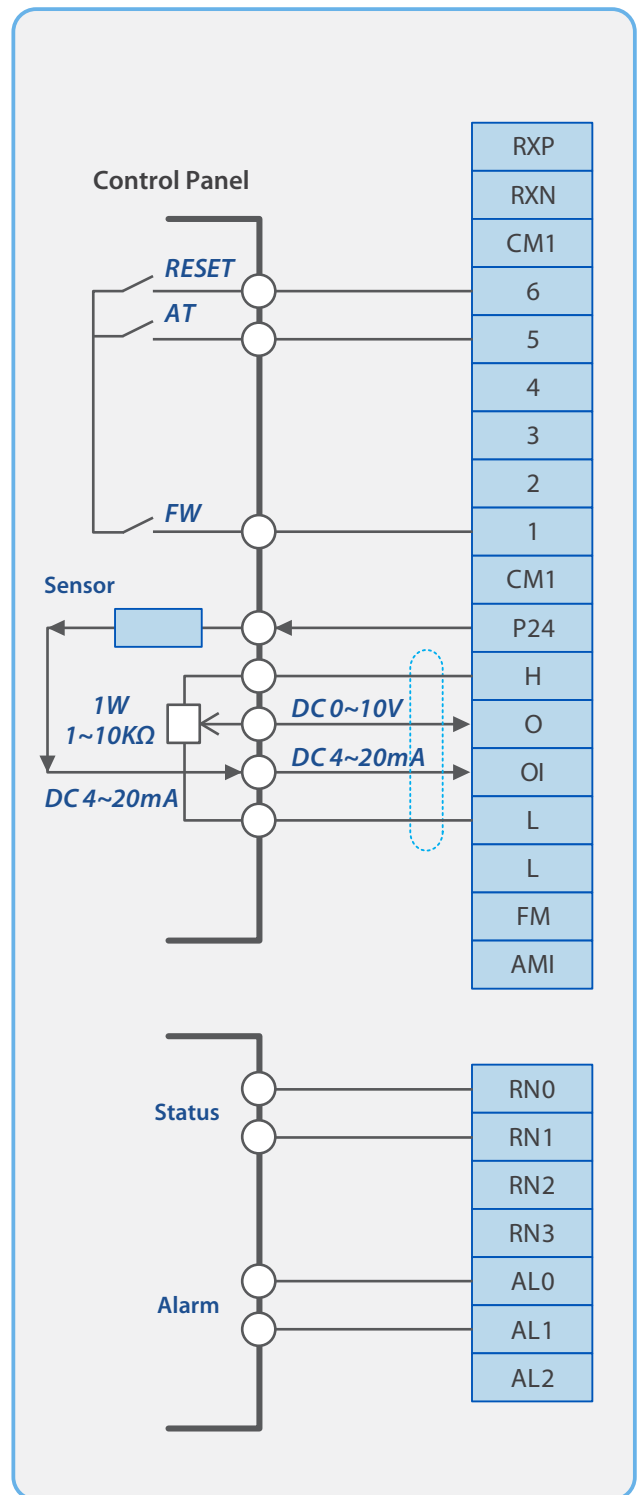

## ■ Washing Machine/Mixer

The connection diagram describes the speed control by multi-speed input and the change rotating direction of motor by FW, RV terminal input. Operating speed change from 1 step to 8 step by combination of CF1~CF3 input. RN signal represents operating status and AL signal is the fault signal. Mixer is controlled by CF1,CF2 terminal.

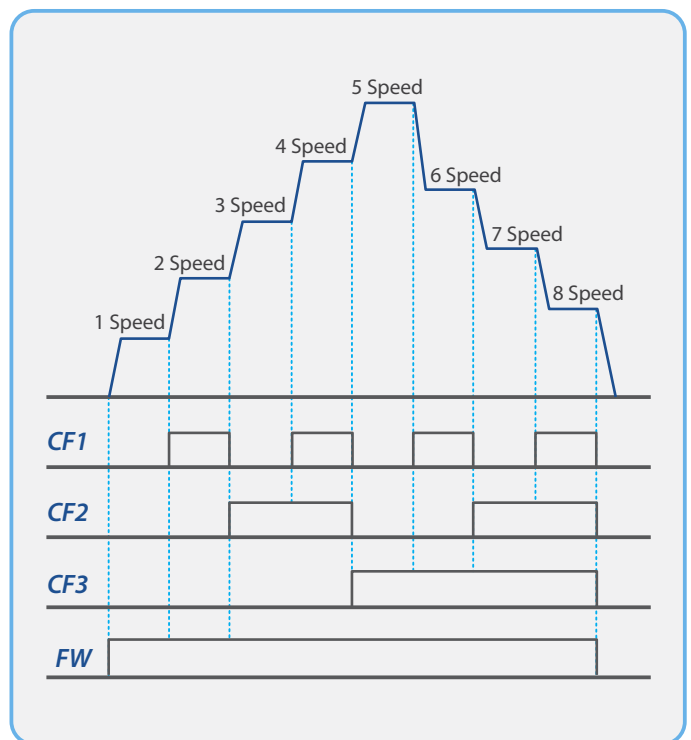
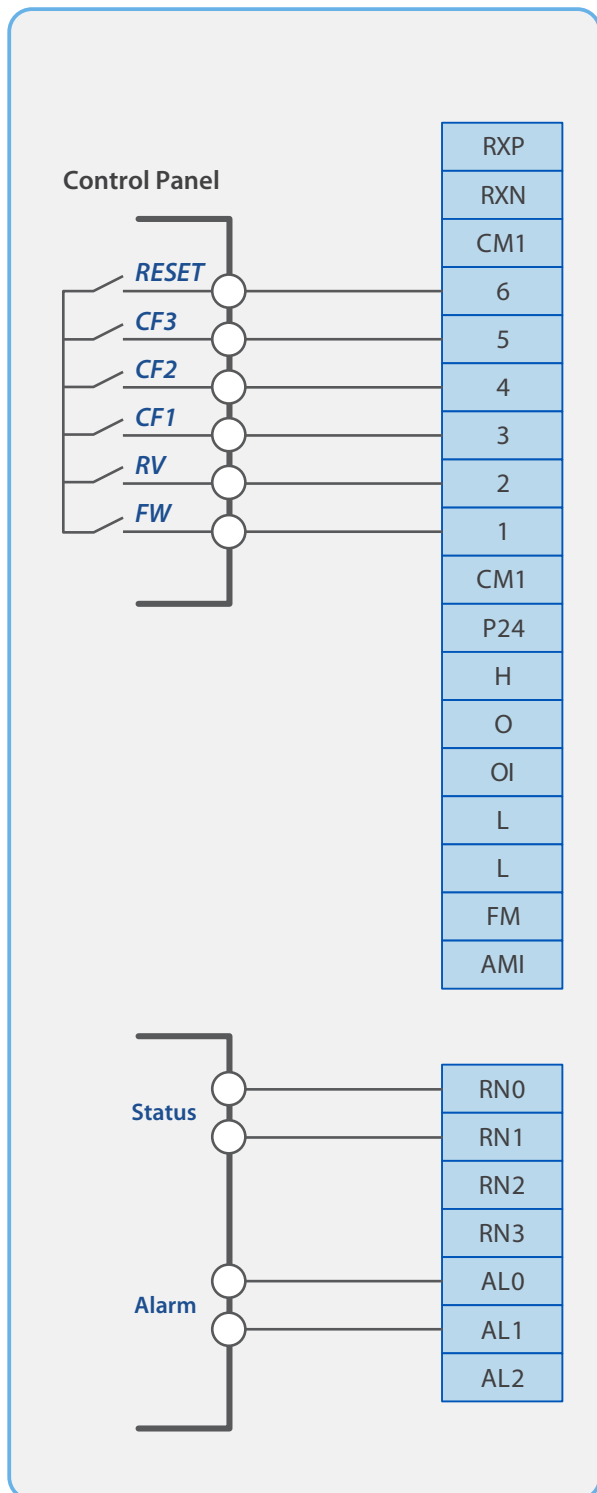

Multi-speed function diagram

# iMaster Series

■ iMaster Series is consists of full range of capacity from Micro to Standard.

HD Rating

0.4kW (0.5HP)    3.7kW (5HP)    7.5kW (10HP)    22kW (30HP)    55kW (75HP)    132kW (200HP)    350kW (450HP)

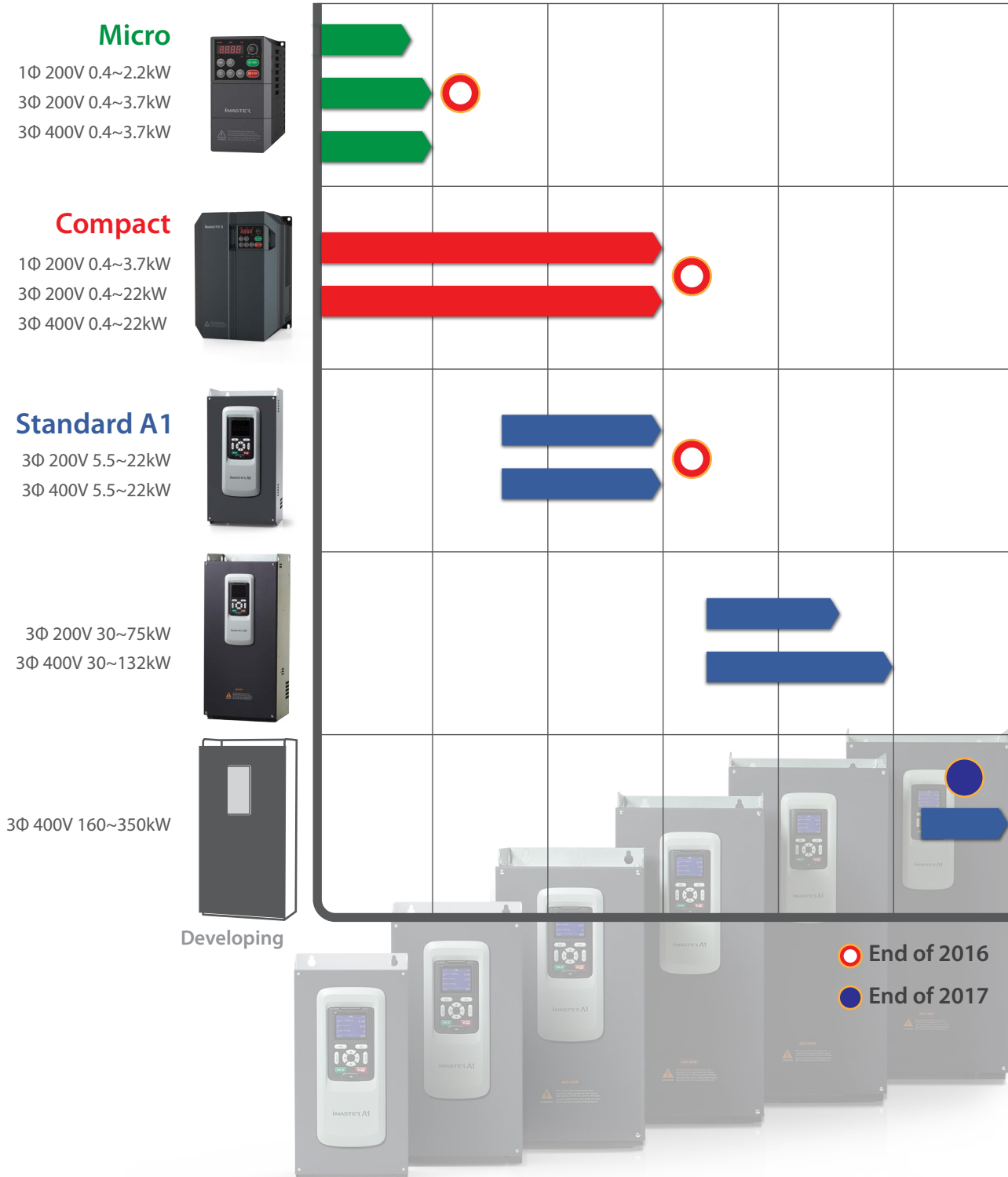

ADT is Motor control and Power conversion solution provider. We are continuously trying to satisfy customers with high technology and best quality

- Founded in November 1999
- Global Power Electronics Company

