

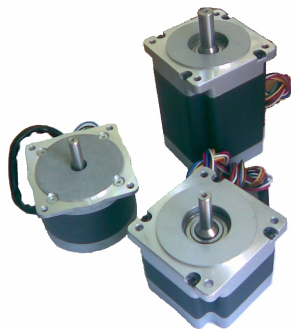

86HS Series Hybrid Stepping Motors



General Specifications

Step Angle Degree	1.8°
Step Angle Accuracy	±5%(full step, no load)
Temperature Rise	80°CMax
Ambient Temperature	-10°C — +50°C
Insulation Resistance	100MΩmin.500VDC
Dielectric Strength	500VAC for one minute
Shaft Radial Play	0.06 Max.(450g-load)
Shaft Axial Play	0.08 max.(450g-load)

Electrical Specifications

Model Number	Connection	Motor Length L inch (mm)	Holding Torque Oz-in (Nm)	Number of Leads	Phase Current (Amps)	Phase Resistance (Ohm)	Phase Inductance (mH)	Rotor Inertia Oz-in-sec ² (g.cm ²)	Detent Torque Oz-in (g.cm)	Weight Oz (kg)
86HS24	Bipolar (Parallel)	2.48 (63)	283.2 (2.0)	8	4.3	0.45±10%	2.5±20%	0.007952 (560)	8.4 (600)	52.91 (1.5)
	Bipolar (Series)		283.2 (2.0)		2.2	1.8±10%	10±20%			
	Unipolar		199.66 (1.41)		3.1	0.9±10%	2.5±20%			
86HS26	Bipolar (Parallel)	2.48 (63)	453.12 (3.2)	8	6.0	0.27±10%	2±20%	0.007952 (560)	8.4 (600)	52.91 (1.5)
	Bipolar (Series)		453.12 (3.2)		3.0	1.1±10%	8±20%			
	Unipolar		328.57 (2.3)		4.3	0.55±10%	2±20%			
86HS38	Bipolar (Parallel)	3.58 (91)	651.36 (4.6)	8	6.0	0.3±10%	2.7±20%	0.01704 (1200)	11.2 (800)	91.71 (2.6)
	Bipolar (Series)		651.36 (4.6)		3.0	1.2±10%	10.8±20%			
	Unipolar		467.28 (3.3)		4.3	0.6±10%	2.7±20%			
86HS35	Bipolar (Parallel)	2.56 (65)	495.6 (3.5)	8	4.0	0.7±10%	3.9±20%	0.0142 (1000)	11.2 (800)	59.97 (1.7)
	Bipolar (Series)		495.6 (3.5)		2.0	2.8±10%	15.6±20%			
	Unipolar		311.52 (2.2)		2.8	1.4±10%	3.9±20%			
86HS45	Bipolar (Parallel)	3.13 (80)	637.2 (4.5)	8	6.0	0.375±10%	3.4±20%	0.01988 (1400)	18.2 (1300)	81.1 (2.3)
	Bipolar (Series)		637.2 (4.5)		3.0	1.5±10%	14±20%			
	Unipolar		453.12 (3.2)		4.2	0.75±10%	3.4±20%			
86HS85	Bipolar (Parallel)	4.65 (118)	1203.6 (8.5)	8	6.8	0.45±10%	6±20%	0.03834 (2700)	35 (2500)	134.04 (3.8)
	Bipolar (Series)		1203.6 (8.5)		3.4	1.8±10%	24±20%			
	Unipolar		849.6 (6.0)		4.9	0.9±10%	6±20%			

* Above motors are our typical models, and if you need a customization motor, please contact us.

Mechanical Specifications (Unit=mm, 1 inch=25.4mm)

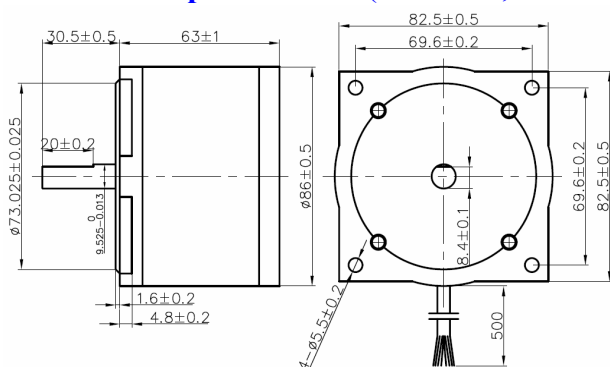

Figure 1: Mechanical specification of the 86HS24

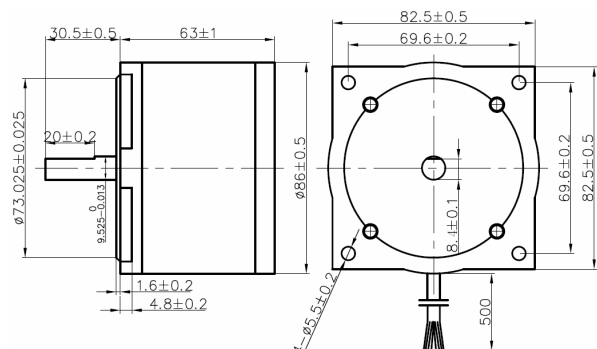

Figure 2: Mechanical specification of the 86HS26

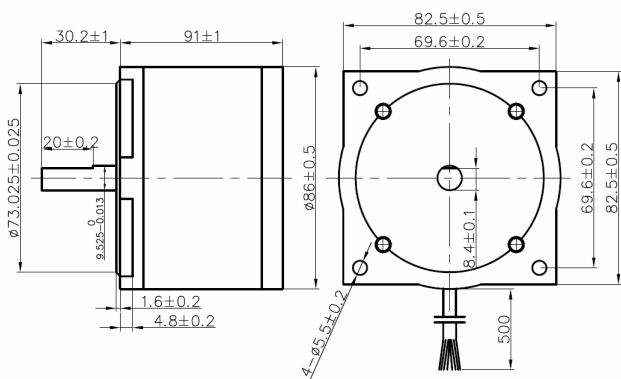

Figure 3: Mechanical specification of the 86HS38

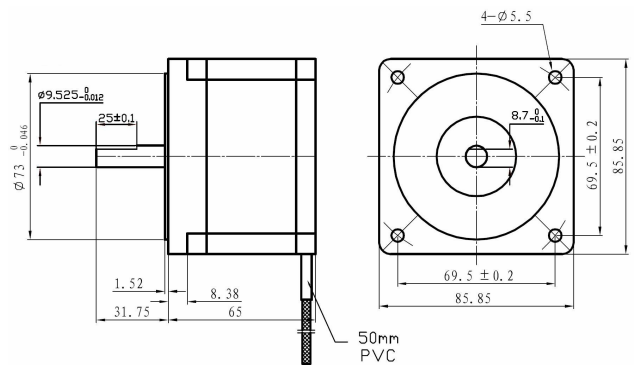

Figure 4: Mechanical specification of the 86HS35

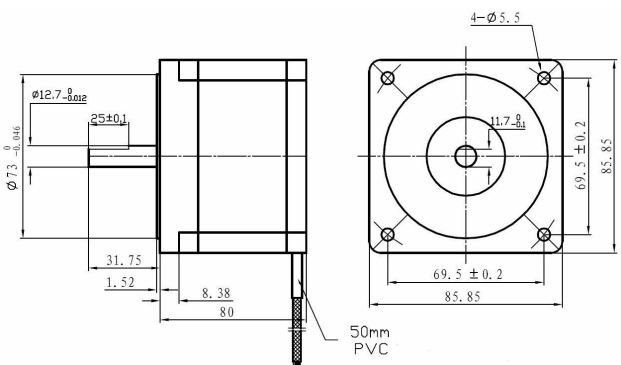

Figure 5: Mechanical specification of the 86HS45

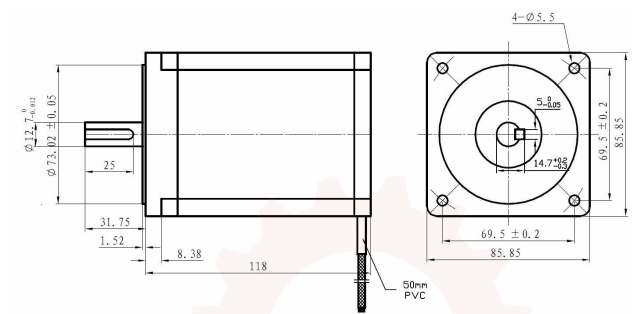
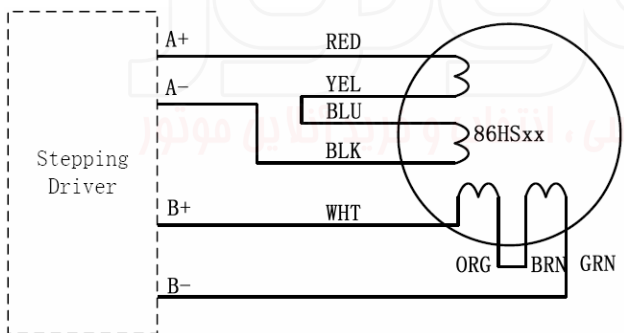
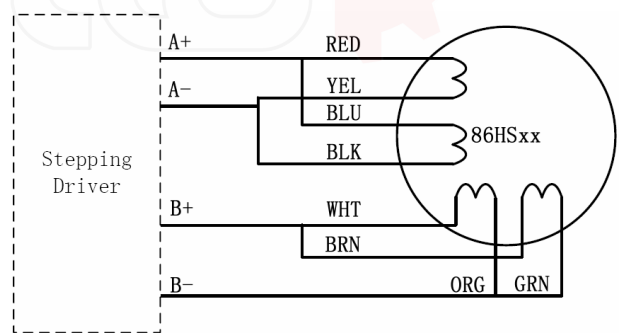

Figure 6: Mechanical specification of the 86HS85

Wiring Diagrams



(a) 86HSxx series connection (8 leads)



(b) 86HSxx parallel connection (8 leads)

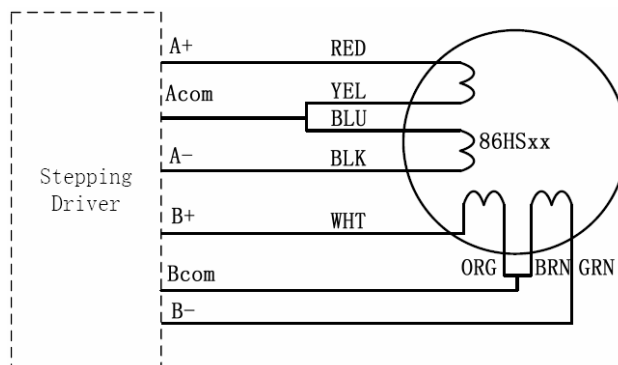

(c) 86HSxx unipolar connection (8 leads)

Figure 7: Wiring diagrams



Speed-Torque Characteristics

Unipolar and bipolar half coil, because we're using less turns, doesn't give us great low speed torque, but because of the low inductance, holds the torque out to high speeds. Bipolar series uses the full coil so it gives very good low speed torque. But because of the high inductance, the torque drops off rapidly. Bipolar parallel also uses the full coil so it gives good low speed performance. And its low inductance allows the torque to be held out to high speeds. But remember, we must increase current by 40% to get those advantages. Speed-torque curves show the maximum torques that can be output at a given speed. When selecting a motor, make sure the required torque falls within the particular curve.

• 86HS24

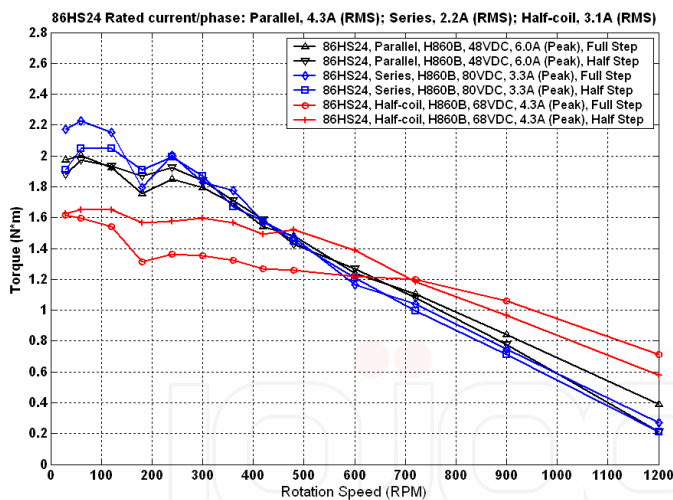

Figure 7: Speed-torque curves of the 86HS24

• 86HS26

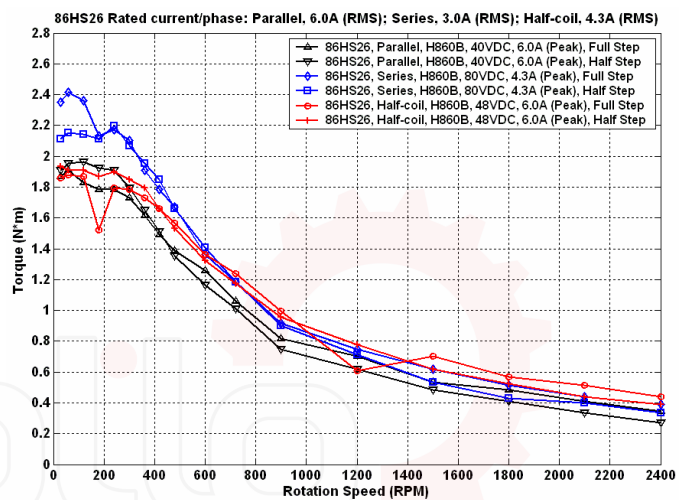

Figure 8: Speed-torque curves of the 86HS26

• 86HS38

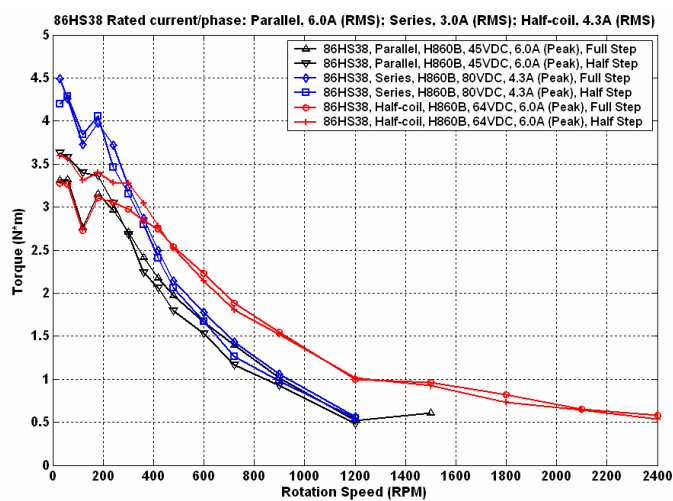

Figure 9: Speed-torque curves of the 86HS38

• 86HS35

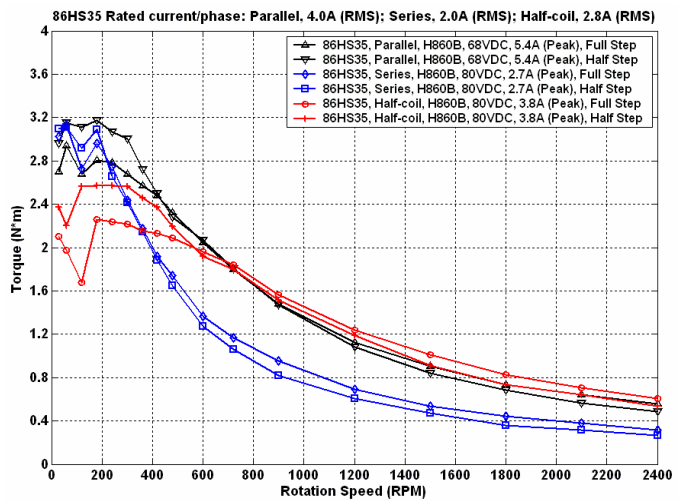

Figure 10: Speed-torque curves of the 86HS35



• 86HS45

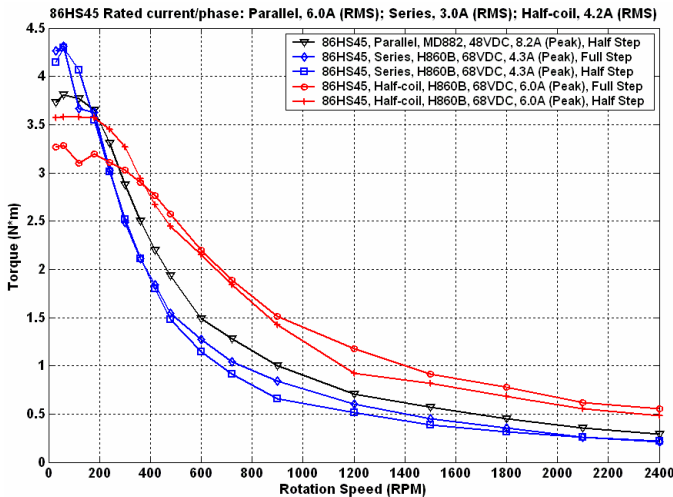

Figure 11: Speed-torque curves of the 86HS45

• 86HS85

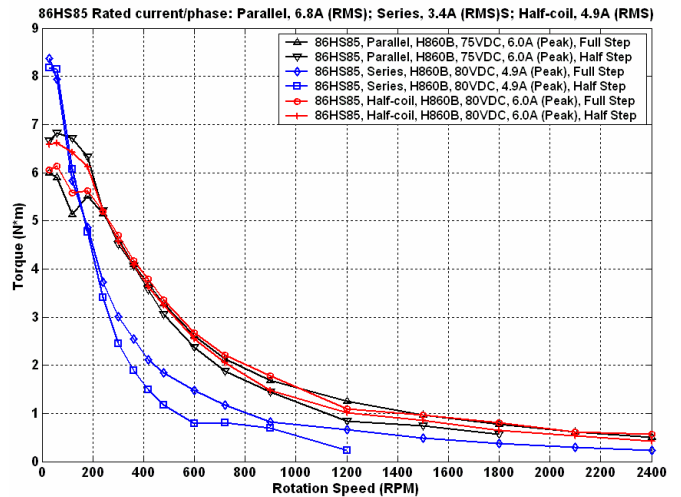

Figure 12: Speed-torque curves of the 86HS85

Remarks:

1. Title "86HS24 Rated current/phase: Parallel, 4.3A (RMS); Series, 2.2A (RMS); Half-coil, 3.1A (RMS)" means "When the 86HS24 used in parallel mode, its current/phase is 4.3A (RMS); When the 86HS24 used in series mode, its current/phase is 2.2A (RMS); When the 86HS24 used in half-coil or unipolar mode, its current/phase is 3.1A (RMS)".
2. Legend "86HS24, Parallel, H860B, 48VDC, 6.0A (Peak), Half Step" means "This speed-torque curve of the 86HS24 (connected in parallel mode) was done with the H860B driver. The settings of the H860B are 6.0A (Peak), Half Step and use 48VDC power supply".
3. The actual characteristics will vary depending on the driver used. Please use these curves only for reference purposes when selecting a motor. You must also conduct a thorough evaluation with the actual driver to be used. Please consult "Leadshine Motor and Driver Packages" for more information about this issue.