

# STANDARD TYPE S9D SERIES [40W]

## MOTOR DIMENSION

UNIT : mm[inch]

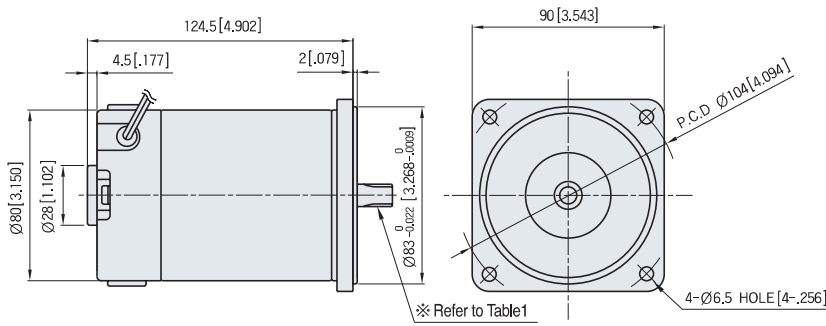

## CHARACTERISTIC CURVE

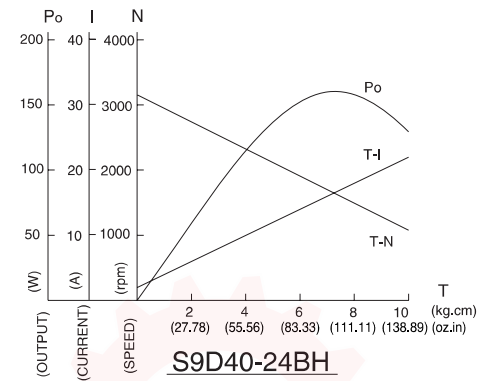

### ▼ SPEC for output shaft of motor-(Table 1)

MODEL	GEARED TYPE	STRAIGHT TYPE	D-CUT TYPE	KEY TYPE
	S9D40-□BH	S9D40-□S	S9D40-□D	S9D40-□K
TYPE OF OUTPUT SHAFT				

## CIRCUIT DIAGRAM

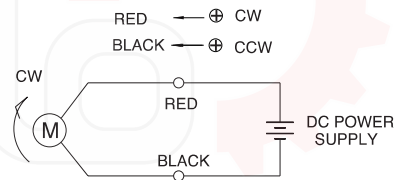

The direction of motor rotation is as viewed from the front shaft end of the motor

## MOTOR SPECIFICATION

( Voltage : DC 24V )

Type	Voltage V	Output W	No Load		At Rated Lod			Run Duty Hr	Weight Kg	
			Speed RPM	Current(MAX.) A	Speed RPM	Torque	Current A			
S9D40-12□	12	40	3100	2.5	2800	0.137	N-m	6.0	2000	1.8
						19.4	oz-in			
						1.40	kgf·cm			
S9D40-24□	24	40	3100	1.5	2900	0.132	N-m	3.0	2000	1.8
						18.7	oz-in			
						1.35	kgf·cm			
S9D40-90□	90	40	3200	0.3	3000	0.127	N-m	0.7	2000	1.8
						18.0	oz-in			
						1.30	kgf·cm			

※ Run duty is valued at rated Voltage and No load

## GEARED MOTOR SPECIFICATION

UNIT : mm[inch]

▼ GEARED MOTOR ※ MOTOR MODEL : S9□40-□□□  
 ※ HEAD MODEL : S9□B3□□~S9□B200□□

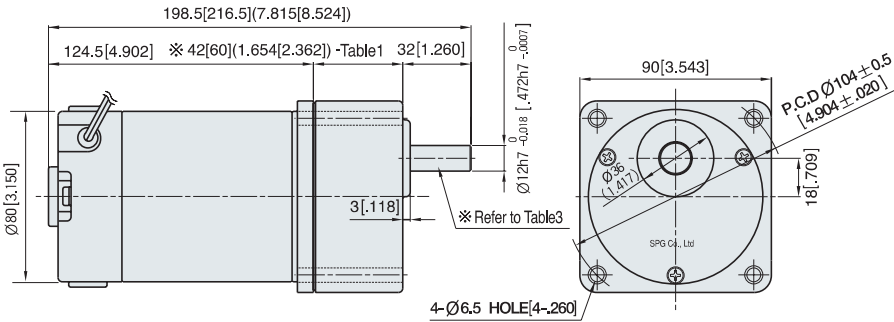

▼ INTER-DECIMAL GEAR HEAD  
 ※ MODEL : S9GX10B(H,L)

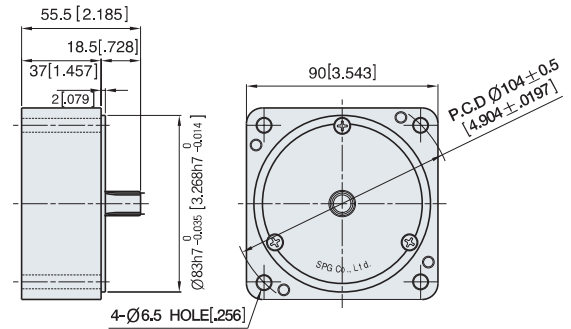

▼ ※30(40) – (Table1)

GEAR RATIO	SIZE:mm[inch]
S9 □ B3□□ ~S9 □ B18 □□	42[1.654]
S9 □ B20 □□ ~S9 □ B200 □□	60[2.362]

▼ WEIGHT – (Table2)

PART	WEIGHT:kg[oz]	
MOTOR	0.6/0.7	
DECIMAL GEAR HEAD	0.60(21.2)	
GEAR HEAD	S9 □ B3 □□ ~ S9 □ B18 □□	0.73(25.7)
	S9 □ B20 □□ ~ S9 □ B40 □□	1.03(36.3)
	S9 □ B50 □□ ~ S9 □ B200 □□	1.13(39.9)

▼ SPEC for output shaft of gearhead-(Table3)

MODEL	TYPES OF OUTPUT SHAFT
S9SB3 □□ ~S9SB200 □□	STRAIGHT TYPE 
	D-CUT TYPE 
S9DB3 □□ ~S9DB200 □□	KEY TYPE 

▼ KEY SPEC

GEAR HEAD	MOTOR

## GEAR HEAD RATED LOAD

S9D40-24BH

MODEL	GEAR RATIO	3	3.6	5	6	7.5	9	10	12.5	15	18	20	25	30	36	40	50	60	75	90	100	120	150	180	200
	No Load rpm		1033	861	620	517	413	344	310	248	207	172	155	124	103	86	78	62	52	41	34	31	26	21	17
S9KB□□	N-m	0.32	0.39	0.54	0.64	0.80	0.96	1.07	1.34	1.61	1.93	1.93	2.41	2.89	3.47	3.86	4.34	5.21	6.51	7.81	8.68	9.80	9.80	9.80	9.80
	oz-in	45.5	54.6	75.9	91.0	113.8	136.6	151.7	189.7	227.6	273.1	273.1	341.4	409.7	491.6	546.3	614.6	737.5	921.8	1106.2	1229.1	1387.7	1387.7	1387.7	1387.7
	kgf · cm	3.3	3.9	5.5	6.6	8.2	9.8	10.9	13.7	16.4	19.7	19.7	24.6	29.5	35.4	39.4	44.3	53.1	66.4	79.7	88.6	100.0	100.0	100.0	100.0

- The code in ■ of gearhead model is for gear ratio
- It is the permissible torque of the assembled motor and gearhead  
 The permissible torque of the combination of the regular gearhead and the inter-decimal gearhead is 30kgf · cm.
- ■ color indicates that the output shaft of the geared motor rotates in the same direction as the output shaft of the motor.  
 Others indicate rotation in the opposite direction.
- No Load rpm equals Motor no load rpm divided by gear ratio. The actual rotation speed is less 2-20% than the displayed value according to the load
- There is no marked the 'L' code for it is an exclusive use.