





CONTENT

CHAPTER 1 INSTALLATION.....	7
CHAPTER 2 BASIC CONFIGURATION	8
CHAPTER 3 WIRING.....	11
CHAPTER 4 KEYBOARD.....	14
CHAPTER 5 COMMON BASIC PARAMETERS.....	18
CHAPTER 6 FUNCTION PARAMETERS	24
CHAPTER 7 APPLICATION MACRO EXAMPLES	107
CHAPTER 8 RS485 COMMUNICATION	152
CHAPTER 9 FAULT RESOLUTION AND REPAIR	159
CHAPTER 10 TECHNICAL NOTES	162
CHAPTER 11 SELECTION OF BRAKING RESISTOR.....	163
CHAPTER 12 DIMENSIONS	167
CHAPTER 13 QUICK PARAMETER CONFIGURATION TABLE.....	168
CHAPTER 14 STANDARD CARD (H10001) INSTRUCTIONS FOR USE	170

Safety Precautions

- Always observe safety precautions to prevent accidents and potential hazards.
- In this manual, the safety information is classified as below:
 -  **WARNING** Fault operation may result in serious personal injury or death
 -  **CAUTION** Fault operation may result personal injury or property damage from minor to moderate class.
- In this manual, the following signs are used as safety precautions::
 -  Under certain conditions, identify dangers that cause personal injury.
 - 1) Since dangerous voltages may exist, special attention should be paid.
-  Under certain conditions, identify potential hazards.
Read the information carefully and follow the instructions.
For convenience, please save it nearby.
- Read this manual carefully to optimize the performance of H1 series inverter and ensure safe use.

Warning

Do not open the casing in case of electric shock when the power supply has been supplied or the inverter is in the running state,
Do not operate the inverter when the front-cover of the inverter is opening. In case of shocked by high voltage or exposed charging capacitors.
Do not open the inverter's casing except for periodic inspection or wiring,, even if the inverter is not connected to input voltage. In case of get an electric shock from the charging circuit. □
Wiring and periodic maintain should be performed after removing the input power and using the instrument to discharge the DC voltage (below DC 30V) for at least 10 minutes. In case of electric shock.
Start the switch with dry hands in case of get an electric shock.
Do not use cables with damaged insulation in case of an electric shock.
Do not make the cable to scratches, pinch, overvoltage or overload in case of an electric shock.

Notes

The inverter should be installed on a non-flammable surface, and do not place flammable materials nearby. Otherwise, a fire may occur.
If the inverter is damaged, immediately disconnect the input power in case of cause secondary damage to the equipment or fire.
After the input power is disconnected, the residual heat of the inverter will remain for several minutes. Do not touch it. Otherwise, you may be physically injured (for example: skin burns or injuries).
Do not power on the inverter that is damaged or missing parts, even if the installation has been completed. Otherwise, electric shock may occur.
Burlap, paper dust, wood dust, dust, metal fragments or other miscellaneous objects are not allowed to enter the inverter. Otherwise, fire or accident may occur.

Operational precautions

- (1) Maintenance and installation
- □ Handle according to the weight of the product.
 - □ The number of stacked inverter packaging boxes should not exceed the specified number.
 - □ Installation according to the instructions in this manual.
 - □ Do not open the casing during delivery.
 - □ Do not place heavy objects on the inverter.
 - □ Check if the inverter's packing direction is correct.
 - □ Do not drop or squeeze the inverter.
 - □ For 200V inverters, use category 3 grounding method (grounding resistance <100Ω), for 400V inverters (grounding resistance <10Ω)
 - □ H1 series contains ESD (electrostatic discharge) sensitive parts. When inspecting or installing, be

- careful to take protective measures (electrostatic discharge) before touching the printed circuit board.
- □Use the inverter under the following environmental conditions.

Table 0-1: Environmental conditions

Envi ron men t	Temperature	-10°C~+40°C. Ambient temperature is 40 °C~ 50 °C(please use derating)
	Humidity	5%~95%RH, No condensation
	Storage temperature	-40°C~+70°C
	Installation site	Indoor, no direct sunlight, no dust, corrosive gas, flammable gas, oil mist, water vapor, dripping water or salt etc.
	Altitude	For derating above 1000 meters, derate 10% for every 1000 meters
	Vibration	Less than 5.9 m / s 2 (0.6g)

(2) Wiring

Do not install power capacitors, surge suppressors, or RFI filters on the output side of the inverter. The connection method of the output cables (U, V, W) connected to the motor will affect the rotation direction of the motor.

Incorrect terminal wiring may cause damage to the device.

If the positive and negative poles of the terminals are reversed, the inverter may be damaged.

Only personnel who are familiar with the H1 inverter can wire and inspect the inverter.

Install the inverter before wiring, otherwise, you may get an electric shock or personal injury.

(3) Trial operation

Check all parameters before operation and modify the parameter values according to the load type.

Always use within the voltage range in this manual, otherwise the inverter may be damaged.

(4) Operation prevention

When the automatic restart function is selected, since the motor will restart suddenly after the fault stops, it should be away from the device.

The "STOP" key on the operation keyboard is only effective when the corresponding function settings have been set, and special circumstances should be prepared for emergency stop switch.

If the fault reset is set using external terminals, a sudden start will occur. Please check in advance whether the external terminal signal is in the off position, in case of an accident may occur.

Do not modify or change anything inside the inverter.

The electronic thermal protection function of the inverter may not protect the motor.

Do not use electromagnetic AC contactor as the switch for frequent start and stop of the inverter on the input side of the inverter.

Use a noise filter to reduce the influence of electromagnetic interference generated by the inverter, in case of nearby electronic equipment may be interfered.

If the input voltage is unbalanced, an AC reactor needs to be installed. The potential higher harmonics from the inverter may cause the power capacitor and generator to become hot or damaged.

After the parameters are initialized, the parameter values are restored to the factory settings, and the parameters need to be set again before running.

The inverter can be easily set to high-speed operation. Check the capacity of the motor or mechanical equipment before operation.

When the DC braking function is used, there will be no stopping torque. When it is necessary to stop the torque, install a separate device.

When driving 400V inverters and motors, use insulated rectifiers and take measures to suppress surge voltage.

The surge voltage caused by the wiring constant problem at the motor terminals may damage the insulation and damage the motor.

(5) Accident prevention

Prepare a safety device, such as an emergency braking device, to prevent the use of machinery and equipment in a more dangerous environment if the inverter has problems.

(6) Maintenance, inspection and parts replacement

Do not test the control circuit of the inverter (insulation resistance measurement) with a high resistance meter. Regular inspection.

(7) Disposal

Disposal as industrial waste after broken.

(8) General notes

Most charts or drawings in this manual indicate that if the inverter is not equipped with a circuit breaker, enclosure or partial open circuit, the inverter must never be operated. When operating the inverter, always install the enclosure and circuit breaker, and observe the regulations in the installation manual.

H1series nameplate

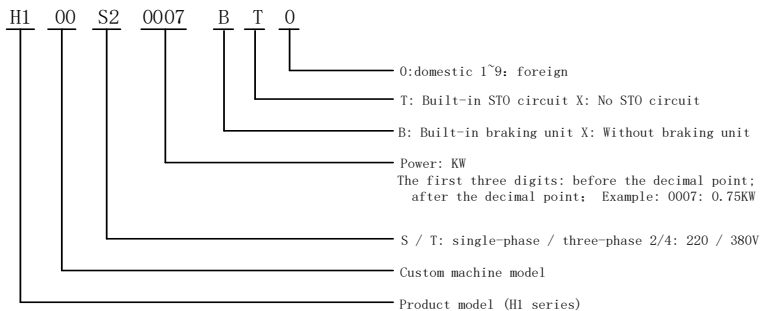

H1series specification

Frame NO.	Model	Input voltage	Input current (A)	Rated power (KW)	Output current (A)	Motor (KW)
F1	H100S20007 BX0	Single-phase 220V	8.2	0.75	5.0	0.75

F100 series vector control inverter manual V1.0

	H100S20015 BX0	Single-phase 220V	14.0	1.5	7.0	1.5
F2	H100T20022 BX0	Single-phase 220V	23.0	2.2	12.5	2.2
		Three phase 220V	13.5			
F3	H100T20037 BX0	Single-phase 220V	38.6	3.7	15.2	3.7
		Three phase 220V	16.5			
	H100T20055 BX0	Three phase 220V	24	5.5	23	5.5
F4	H100T20075 BX0	Three phase 220V	37	7.5	31	7.5
	H100T20110 BX0	Three phase 220V	52	11	45	11
F1	H100T40007 BX0	Three phase 380V	4.0	0.75	3.0	0.75
	H100T40015 BX0	Three phase 380V	5.8	1.5	4.5	1.5
	H100T40022 BX0	Three phase 380V	6.5	2.2	5.6	2.2
F2	H100T40040 BX0	Three phase 380V	12.6	4.0	10.5	4.0
F3	H100T40055 BX0	Three phase 380V	16	5.5	14	5.5
	H100T40075 BX0	Three phase 380V	21	7.5	19	7.5
F4	H100T40110 BX0	Three phase 380V	28	11	26	11
	H100T40150 BX0	Three phase 380V	36	15	33	15
F5	H100T40185 BX0	Three phase 380V	42	18.5	40	18.5

F100 series vector control inverter manual V1.0

	H100T40220 BX0	Three phase 380V	48	22	46	22
--	-------------------	------------------------	----	----	----	----

Chapter 1 Installation

1.1 Installation prevention



Warning

- The inverter uses plastic parts, so be careful not to damage it. Do not grab the front keyboard to move the inverter in case of fall.
- The inverter is installed without vibration (5.9 m/s^2 or less).
- Install the inverter within the allowable temperature range ($-10 \sim 50\text{C}$).
- The temperature of the inverter during operation is very high, and the inverter needs to be installed on a non-flammable surface.
- Install the inverter on smooth, vertical and horizontal surfaces. The direction of the inverter must be vertical for heat dissipation. At the same time, leave enough space around the inverter.

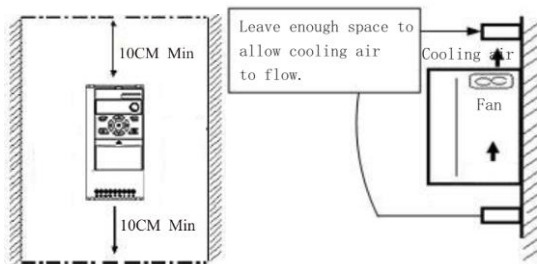

Chart 1-1 Installation instructions

- [Avoid moisture and direct sunlight.
- [Do not install the inverter in places with oil gas, flammable gas and dust. Install the inverter in a clean place or in a closed plate that isolates foreign materials.
- [When two or more inverters are installed on one space, the inverter or cooling fan must be installed in a suitable location to ensure that the surrounding temperature is within the allowable range.
- [When installing the inverter, use screws for fixing to ensure that the inverter is firmly installed.

Chapter 2 Basic Configuration

2.1 Outside equipment connection

The following equipment is required to operate the inverter. Select appropriate outside equipment and connect it correctly to ensure normal operation. Fault application or installation of the inverter may cause system failure or reduce product life and damage components. Before proceeding, you must read and fully understand the manual.

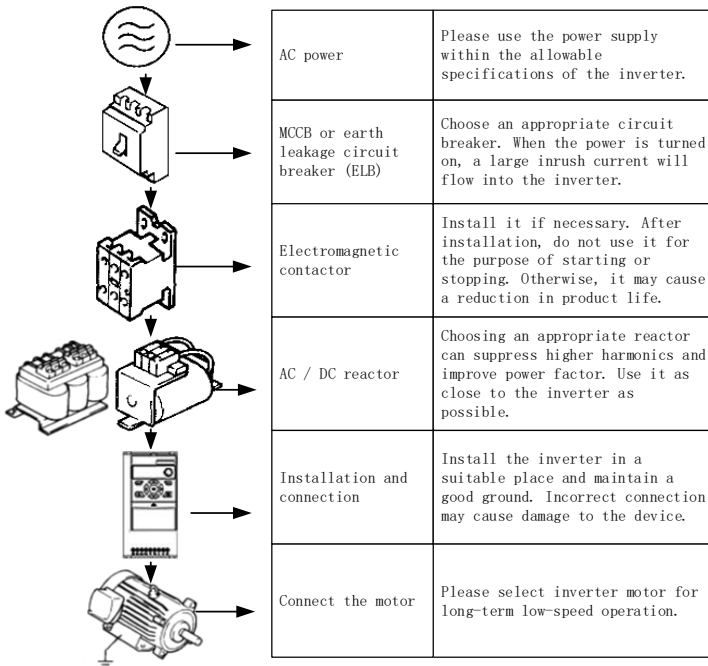

Chart 2-1 Diagram connection of outside equipments and inverter

2.2 List of main circuit applicable devices and their electrical specifications

Voltage class (V)	Inverter rated power (KW)	Motor (KW)	Inverter input		Recommended wiring size (mm ²)			
			Air-switch model	Contactor model	Power line (input / output line)	DC reactor	Braking circuit	Control signal wire (external wiring)
220	0.75	0.75	DZ20-100(16A)	CJ20-16	2	4	2.5	0.5~0.75
	1.5	1.5			5			
	2.2	2.2	DZ20-100(32A)	CJ20-40	4	6	4	
	3.7	3.7						
	5.5	5.5	DZ20-100(32A)	CJ20-40	4	6	4	
	7.5	7.5	DZ20-100(50A)	CJ20-40	6	6	4	
	11	11	DZ20-100(63A)	CJ20-63	8	8	6	
	0.75	0.75	DZ20-100(16A)	CJ20-16	1.5	4	1.5	
	1.5	1.5			2.5		2.5	
	2.2	2.2						
	4.0	4.0						

38 0	5.5	5.5	DZ20-100(3 2A)	CJ20-2	4	6	4
	7.5	7.5		5			
	11	11	DZ20-100(5 0A)	CJ20-4	6	8	6
	15	15			8		
	18.5	18.5		0			
	22	22	DZ20-100(6 3A)	CJ20-6	10	16	
			3				

Chapter 3 Wiring

3.1 Main circuit and function card

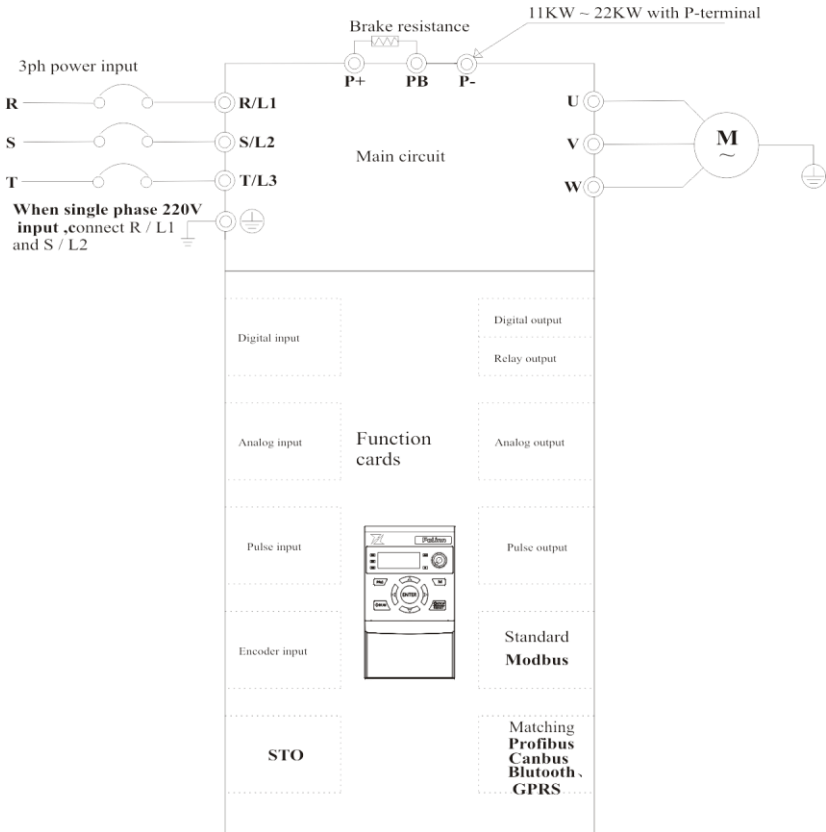

Chart 3-1 Main circuit and function card

Note: Different function cards connect to different terminals. In addition to standard function cards, any type of card can be customized.

When using different function cards, the parameters need to be reset.



Warning: It is strictly forbidden to plug and unplug the function card with power on!

3.2 Power terminal wiring instructions



Warning

For 220V class inverter, use class 3 grounding method (grounding resistance: less than 100).

For 380V class inverter, use class 3 grounding method (grounding resistance: less than 10).

Use special grounding terminal for grounding. Do not use screws for grounding in the box.

Note: Grounding steps

(1) Determine the location of the ground terminal.

(2) Connect the ground-wire to the ground terminal and make sure that the screws are tight.

3.3 Main circuit terminal description

Terminal symbol	Terminal name	Function description
	Ground terminal	Inverter safety ground
R/L1、S/L2、T/L3	Main circuit power input terminal	Connect three-phase power, single-phase power to R / L1, S / L2
P+、PB	Brake terminal	Connect external braking resistor
P+、P-	DC bus terminal	when two or more inverters share a DC bus (11KW ~ 22KW have P-terminal)
U、V、W	Inverter output terminal	Connect a three-phase motor

Please implement the wiring in accordance with the regulations of electrician regulations to ensure safety. When selection of the wire diameter specification,

It is best to use isolated wires or conduits for power wiring, and ground the isolation layer or conduits at both ends.

Be sure to install the air disconnect switch NFB between the power supply and the input terminals (R / L1, S / L2, T / L2)

Do not connect the AC power supply to the output terminal (U V W) of the inverter.

The output wiring must not touch the metal shell of the inverter, in case of a short circuit to ground.

Do not use phase shift capacitors, LC / RC noise filters and other components at the output of the inverter.

The main circuit wiring of the inverter must be far away from other control equipment.

When the wiring between the inverter and the motor exceeds 15 meters (220V level), (380V level 30 meters), a high dV / dT will be generated inside the motor coil, which will produce interlayer insulation of the motor then damaged, please use a special motor for the inverter or install a reactor on the inverter side.

Ground wire:

Please correctly ground the grounding wire terminal PE:

220V level: The 3 class grounding (grounding resistance below 100).

380V: Special 3 class grounding (grounding resistance below 10).

For the use of the ground wire, please follow the basic length and size of the electrical equipment technology.

Use special grounding terminal for grounding. Do not use screws for grounding in the box.

Absolutely avoid public grounding with large power equipment such as welding machines, power machinery, etc.

The ground wire should be as far away as possible from the ground wire of large power equipment.

The ground wiring must be as short as possible.

Note: Grounding steps

- (1) Remove the front keyboard.
- (2) Connect the ground wire to the ground terminal and ensure that the screws are tight.

3.4 The Parameter table of function card

Function card	H1	H2	H3	H4	H5	H6	H7	H8	H9	H0	H1	H2
	0	0	0	0	0	0	0	0	0	0	1	1
Features	1	2	3	4	5	6	7	8	9	0	1	2
Digital input	4	3	4	8	2	2	3	2	2	4	4	3
Digital output								4	4			
Relay output	1		3	1	1	1	1	1	1	1	1	1
Analog input	1		1		2			1	1	1	1	1
Analog output					2			1	1			
Pulse input						1						
Pulse output						1						
Encoder input							1					
MODBUS	1	1	1	1	1	1	1	1	1	1	1	1
PROFIBUS								1				
CANBUS									1			
Bluetooth										1		
GPRS											1	
STO												1
Typical application												

Note: Only one function card can be selected for each inverter !

Chapter 4 Keyboard

4.1 Keyboard Features

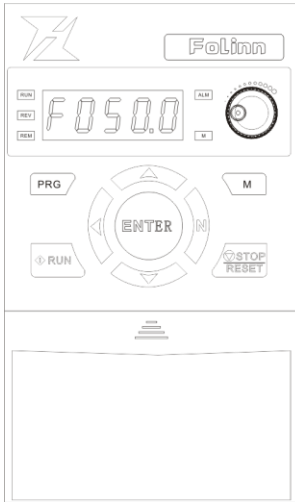

NO.	Construction	Function explain
1		Display
2		Programming / Exit key
3		The status display interface is the status switching key,the other interface is the left shift key
4		Reserved key
5		Run key
6		Potentiometer: see parameter P1.63
7		In programming mode, value change key
8		In non-programming mode, increasing and decreasing (UP / DOWN) selection key See parameters P1.63, P2.03, P2.04
9		Enter
10		Stop/reset
11		Customized key

Indicator light	State	Function Detail
RUN	Bright / flash	Running/Decelerate
REV	Bright	Reversing
REM	Bright	Remote start

ALM	Bright	Fault indication
M	Bright	Customer customized instructions, fault alarm instructions, see parameters P1.66 and P1.67.

4.2 Keyboard operation

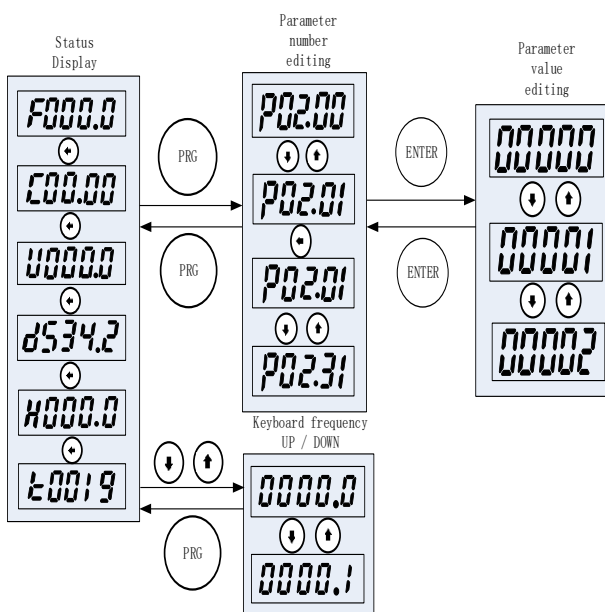

Item	Description
F	Output frequency
C	Output current

U	Output voltage
d	Bus voltage
H	Display value 1 (selected by P1.68)
L	Display value 2 (selected by P1.69)
A	Alarm
E	Fault

4.3 Character display

0	0	A	A	K	K	U	U
1	1	b	B	L	L	V	V
2	2	c	C	M	M	W	W
3	3	d	D	N	N	X	X
4	4	E	E	O	O	Y	Y
5	5	F	F	P	P	Z	Z
6	6	L	G	Q	Q		
7	7	H	H	R	R		
8	8	I	I	S	S		

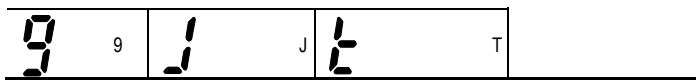

Chapter 5 Common basic parameters

Note:

Some parameters have been set at the factory (factory value), and do not be set for the first use.

5.1 Set the motor rated parameters

After power on, use the operation keyboard to set the parameters as the following table. According to the motor-nameplate for motor parameters.

Parameter number	Function	Parameter number	Function
P6.11	Motor power	P6.14	Motor current
P6.12	Motor Voltage	P6.15	Motor speed
P6.13	Motor frequency		

5.2 Use the keyboard to control the start and stop and the keyboard potentiometer to set the operating frequency

5.2.1 Power on.

Use the operation keyboard to set the motor parameters (P6.11 ~ P6.15), keyboard potentiometer to control speed and acceleration / deceleration time (P2.50, P2.70).

Parameter number	Function	Set value	Detail
P1.63	The source of keyboard settings	1 (Factory Value)	The operating frequency is set by the keyboard potentiometer
P2.10	Set point source	0 (Factory Value)	The operating frequency is set by the keyboard
P3.00	Start command source	1 (Factory Value)	Operation keyboard to run command channel
P3.04	Source of stop command	1	Operation keyboard to stop command channel
P2.50	Acceleration time	-	The acceleration time is adjusted according to actual needs
P2.70	Deceleration time	-	Deceleration time is adjusted according to actual needs

5.2.2 Press the RUN key on the operation keyboard to start the inverter, rotate the potentiometer on the keyboard to adjust the set frequency, and press the STOP key to stop the inverter output.

5.3 Use terminal to control start and stop and keyboard to set operating frequency

5.3.1 Terminal S1 is for forward signal input, and S2 is for reverse signal input. The wiring is as shown in the figure below.

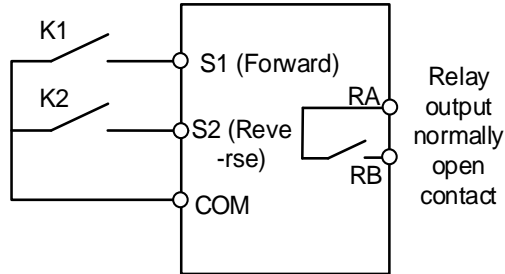

5.3.2 Power on, then set the function parameters according to the wiring diagram, see the table as below.

Parameter number	Function	Set value	Detail
P1.63	Keyboard settings source	0	Keyboard setting source is set by P2.92 number
P2.03	Source of incremental instruction (UP)	1	Incremental command (UP) source keyboard
P2.04	Decrement Instruction (DOWN)	1	Decrease command (DOWN) source keyboard
P2.10	Set value source 1	0 (Factory value)	The operating frequency is set by the keyboard
P2.92	Keyboard settings	-	Operating frequency, relative to P2.18 percentage
P2.50	Acceleration time 0	-	The acceleration time is adjusted according to actual needs
P2.70	Deceleration time 0	-	Deceleration time is adjusted according to actual needs
P3.00	Start command source	3	Forward running function (terminal forward rotation signal input)
P3.01	Reverse start command source	4	Reverse running function (terminal reverse signal input)

5.3.3 When K1 in the wiring diagram is closed, the motor runs forward; when K1 is disconnected, the motor stops running. When K2 is closed, the motor runs in reverse; when K2 is disconnected, the motor stops running. When K1 and K2 are closed or opened at the same time, the motor stops running. You can increase / decrease the set frequency by set the value of P2.92 or pressing and on the operation keyboard.



5.4 Use terminals to control start, stop and analog to set operating frequency

5.4.1 Terminal S1 is for forward signal input, and S2 is for reverse signal input. The wiring is shown in the figure below.

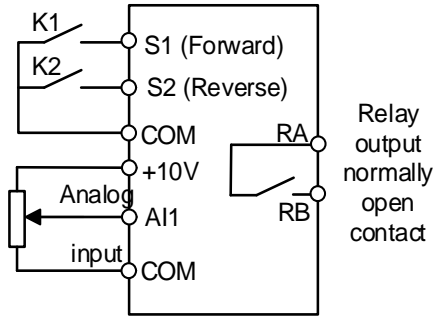

5.4.2 Power on, then set the function parameter table according to the wiring diagram, see the table below.

Parameter number	Function	Set value	Detail
P2.10	Set value source 1	2	The operating frequency is set by analog AI1
P2.50	Acceleration time 0	-	The acceleration time is adjusted according to actual needs
P2.70	Deceleration time 0	-	Deceleration time is adjusted according to actual needs
P3.00	Start command source	3	Forward rotation function (terminal forward rotation signal input)
P3.01	Reverse start command source	4	Reverse function (terminal reverse signal input)

5.4.3 Set the operating frequency by adjusting the AI1 analog input.

5.4.4 When K1 in the wiring diagram is closed, the motor runs forward; when K1 is disconnected, the motor stops running. When K2 is closed, the motor runs in reverse; when K2 is disconnected, the motor stops running. When K1 and K2 are closed or opened at the same time, the motor stops running.

5.5 Process control PID: Multi-step speed 0 is set value, AI1 is feedback value

5.5.1 Terminal S1 is the forward signal input, AI1 is the feedback signal input. The wiring is shown below.

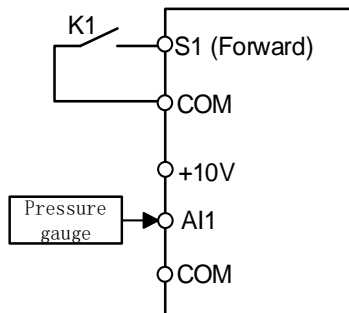

5.5.2 Power on, then set the function parameter table according to the wiring diagram, see the table below.

Parameter number	Function	Set value	Detail
P2.10	Set value source 1	1	PID set value selected multi-step speed 0: 100% of full scale
P2.11	Set value source 2	2	PID feedback selected analog AI1: 10V corresponds to full scale
P2.13	Set channel relationship	8	Activate PID control
P2.30	Multi-speed 0	-	PID set value
P3.00	Start command source	3	Select S1 as the source of the operation command
P4.00	PID proportional gain	-	Set as required, the greater the value, the faster the adjustment
P4.01	PID integration time	-	Set as required, the smaller the value, the faster the adjustment
P1.68	Keyboard monitoring item selection H	1090	Item H displays P10.90, which is the PID setting value
P1.69	Keyboard monitoring item selection T	1091	The T item shows P10.91 which is the PID feedback value

5.5.3 Adjust the P2.30 to get the desired pressure.

5.5.4 When K1 in the wiring diagram is closed, the system starts to run.

5.6 Use terminal to control start-stop and communication to set running frequency

5.6.1 Terminal S1 is for forward signal input and S2 is for reverse signal input. The wiring is as shown in the figure below.

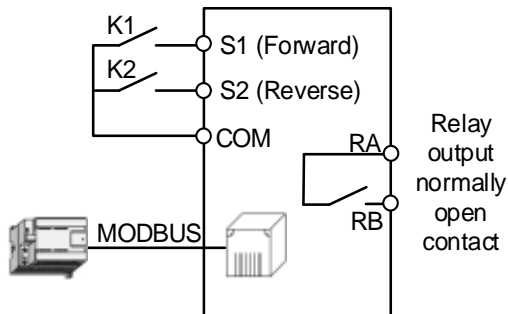

5.6.2 Power on, then set the function parameters according to the wiring diagram, see the table below.

Parameter number	Function	Set value	Detail
P1.40	Protocol	1 (Factory value)	MODBUS RTU

P1.41	Local address	1 (Factory value)	Slave address 1
P1.42	Baud rate	3 (Factory value)	19200bps
P1.43	Parity check	0 (Factory value)	No check
P1.44	Data bit	8 (Factory value)	8 bit
P1.45	Stop bit	1.0(Factory value)	1 bit
P2.10	Setpoint source 1	5	MODBUS communication settings
P2.50	Acceleration time 0	-	The acceleration time is adjusted according to actual needs
P2.70	Deceleration time 0	-	Deceleration time is adjusted according to actual needs
P3.00	Start command source	3	Forward rotation function (terminal forward rotation signal input)
P3.01	Reverse start command source	4	Reverse function (terminal reverse signal input)

5.6.3 When K1 in the wiring diagram is closed, the motor runs forward; when K1 is disconnected, the motor stops running. When K2 is closed, the motor runs in reverse; when K2 is disconnected, the motor stops running. When K1 and K2 are closed or opened at the same time, the motor stops running.

5.6.4 Modify the running frequency by writing register 0x0121 through MODBUS communication (function code 0x06). For example: modify the running frequency of slave address 1 to 25Hz, see the table below.

	Address	Function code	Register address		Register content		Sum of Check	
Request frame	0x01	0x06	0x01	0x21	0xC3	0x50	0x88	0xF0
Reply frame	0x01	0x06	0x01	0x21	0xC3	0x50	0x88	0xF0

5.7 Use communication to control start and stop and communication to set operating frequency

5.7.1 Connect the communication cable as shown below.

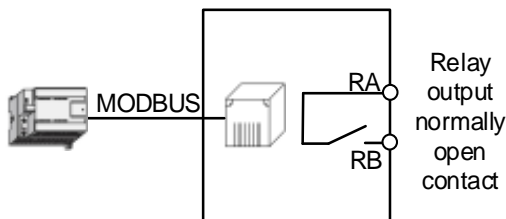

5.7.2 Power on, then set the function parameters according to the wiring diagram, see the table below.

Parameter number	Function	Set value	Detail
P1.40	Protocol	1 (Factory value)	MODBUS RTU
P1.41	Local address	1 (Factory value)	Slave address 1
P1.42	Baud rate	3 (Factory value)	19200bps
P1.43	Parity check	0 (Factory value)	No check
P1.44	Data bit	8 (Factory value)	8 bit
P1.45	Stop bit	1.0 (Factory value)	1bit
P2.10	Set value source 1	5	MODBUS communication setting frequency
P2.50	Acceleration time 0	-	The acceleration time is adjusted according to actual needs
P2.70	Deceleration time 0	-	Deceleration time is adjusted according to actual needs
P3.00	Start command source	2	MODBUS communication starts
P3.04	Source of stop command	2	MODBUS communication stopped

5.7.3 Start or stop the inverter whose slave address 1 by writing register 0x0122 through MODBUS communication (function code 0x06).

Such as: start command, see the table below.

	Address	Function code	Register address		Register content		Check code	
Request frame	0x01	0x06	0x01	0x22	0x00	0x01	0xE9	0xFC
Reply frame	0x01	0x06	0x01	0x22	0x00	0x01	0xE9	0xFC

Such as: stop command, see the table below.

	Address	Function code	Register address		Register content		Check code	
Request frame	0x01	0x06	0x01	0x22	0x00	0x10	0x29	0xF0
Reply frame	0x01	0x06	0x01	0x22	0x00	0x10	0x29	0xF0

5.7.4 Modify the operating frequency by writing register 0x0121 through MODBUS communication (function code 0x06). For example: modify the running frequency of slave address 1 to 20Hz, see the table below.

	Address	Function code	Register address		Register content		Check code	
Request frame	0x01	0x06	0x01	0x21	0x9C	0x40	0xB0	0xC C
Reply frame	0x01	0x06	0x01	0x21	0x9C	0x40	0xB0	0xC C

Chapter 6 Function parameters

Classify	Parameter number	Function	Setting number	unit	Factory value
01 : System parameters	P1.11	Parameter operation	0: Normal Operation; 1: Parameter Initialization, initialization except P 1. XX and apply parameters other than macros; 2: initialize all parameters		0
	P1.13	Set keyword	0~9999		0
	P1.14	Set keyword confirmed	0~9999		0
	P1.15	Input keyword	0~9999		0
	P1.20	Apply macro	0~9999		0
	P1.21	Recipe	0~10000		0
	P1.30	virtual terminal to set	0~199:Value setting; 200~9999:Address		0
	P1.39	Command Mode	0:Single Command source mode; 1:Multi-command source mode		0
	P1.40	Communication Protocol	0:Reserved; 1:MODBUS RTU; 2~6:Reserved		1
	P1.41	Address	0~247		1
	P1.42	Baud Rate	0:2400; 1:4800; 2:9600; 3:19200; 4:38400; 5~10:Reserved	bps	3
	P1.43	Parity Check	0:No Check; 1:Even check; 2:Odd check		0
	P1.44	Data Bit	8~9	Bits	8
	P1.45	Stop Bit	0.0~2.0	Bit	1.0
	P1.47	parameter decimal mode	0~123		0
P1.63	Keyboard settings source	0: Keyboard numeric setting (P2.92); 1: Keyboard potentiometer setting		1	

F100 series vector control inverter manual V1.0

	P1.66	keyboard M light Source	0: always 0; 1: always 1; 2: stopped; 3: running; 4: fault; 5: Warning; 6: Reversing; 7: ready; 64: STO state; 100 ~ 9999: address		5
	P1.67	Keyboard M Lamp source Bit display	0~31		0
	P1.68	value 1 source	0~9999		1011
	P1.69	value 2 source	0~9999		1091
02 : Setting channel	P2.00	Multi-speed source	0~11111111		0
	P2.01	Source of acceleration time	Units: S1; Tens: S2; Hundreds: S3; ...		0
	P2.02	Source of deceleration time	...		0
	P2.03	Source of incremental instruction (UP)	Units: keyboard; Tens: communication; Hundreds: S1; Thousands: S2; ...		0
	P2.04	Source of Decrement instruction (DOWN)	...		0
	P2.10	Set value source 1	0: keyboard; 1: Multi-speed;		0
	P2.11	Set value source 2	2: AI1; 3: AI2;		0
	P2.12	Setpoint source 3	5: communication; 9: pulse input 200 ~ 9999: address		0
	P2.13	Set channel 1 relationship selection	0:F1; 1:F2; 2:F1+F2; 3:F1-F2; 4:F1*F2/100;		0
	P2.14	Set channel 2 relationship selection	5:Maximum value(F1,F2); 6:Minimum value(F1,F2) ; 7:Average value(F1,F2) ; 8:PID(F1,F2);		0
	P2.18	Maximum setting			50.000
	P2.19	Minimum setting	-99999.000~99999.000		0.000
	P2.20	Avoid-frequency start point			
	P2.21	Avoid-frequency stop point			
P2.22	Avoid-frequency start point				
P2.23	Avoid-frequency stop point				
			-1000.000~1000.000	%	0.000

P2.24	Jog Frequency	-1000.000~1000.000	%	10.000
P2.26	Increase and decrease (UP / DOWN) Step-frequency	-100.0~100.0	%	0.2
P2.27	Increase and decrease (UP / DOWN) memory selection	0: no memory; 1: Only power down memory; 2: Only stop memory; 3: Both power down and stop memory		3
P2.28	Speed up and down frequency	-1000.000~1000.000	%	0.000
P2.30	Multi-speed 0	-1000.000~1000.000	%	0.000
P2.31	Multi-speed 1			
P2.32	Multi-speed 2			
P2.33	Multi-speed 3			
P2.34	Multi-speed 4			
P2.35	Multi-speed 5			
P2.36	Multi-speed 6			
P2.37	Multi-speed 7			
P2.38	Multi-speed 8			
P2.39	Multi-speed 9			
P2.40	Multi-speed 10			
P2.41	Multi-speed 11			
P2.42	Multi-speed 12			
P2.43	Multi-speed 13			
P2.44	Multi-speed 14			
P2.45	Multi-speed 15			
P2.50	Accelerate time 0	0.050~3600.000	S	*
P2.51	Accelerate time 1			
P2.52	Accelerate time 2			
P2.53	Accelerate time 3			
P2.54	Accelerate time 4			
P2.55	Accelerate time 5			
P2.56	Accelerate time 6			
P2.57	Accelerate time 7			
P2.58	Accelerate time 8			
P2.59	Accelerate time 9			
P2.60	Accelerate time 10			
P2.61	Accelerate time 11			
P2.62	Accelerate time 12			
P2.63	Accelerate time 13			
P2.64	Accelerate time 14			
P2.65	Accelerate time 15			

P2.66	Jog acceleration time	0.050~3600.000	S	5.000
P2.68	S curve acceleration time 1	0.000~100.000	%	0.000
P2.69	S curve acceleration time 2			
P2.70	Deceleration time 0	0.050~3600.000	S	*
P2.71	Deceleration time 1			
P2.72	Deceleration time 2			
P2.73	Deceleration time 3			
P2.74	Deceleration time 4			
P2.75	Deceleration time 5			
P2.76	Deceleration time 6			
P2.77	Deceleration time 7			
P2.78	Deceleration time 8			
P2.79	Deceleration time 9			
P2.80	Deceleration time 10			
P2.81	Deceleration time 11			
P2.82	Deceleration time 12			
P2.83	Deceleration time 13			
P2.84	Deceleration time 14			
P2.85	Deceleration time 15			
P2.86	Jog deceleration time	0.050~3600.000	S	5.000
P2.87	Safe deceleration time	0.050~3600.000	S	5.000
P2.88	S curve deceleration time 1	0.000~100.000	%	0.000
P2.89	S curve deceleration time 2			
P2.90	Communication set value	-1000.000~1000.000	%	0.000
P2.91	Communication demand	0~4294967295		0
P2.92	Keyboard set value	-1000.000~1000.000	%	100.000
P2.93	Keyboard demand	0~4294967295		0
P3.00	Start command source	Bit16 ~ Bit31: Bits 0 ~ 15 of P1.30 0 ~ 4294967295 Single command source mode (P1.39 = 0): 0: No effect; 1: keyboard;		1
P3.01	Reverse start command source			0
P3.02	Reverse command source			0
P3.03	Jog command			1

03 : Input and output		source	2: communication; 3: S1; 4: S2		
	P3.04	Source of stop command	...		0
	P3.05	Free parking order source	17 ~ 32: The 0 ~ 15 bits of P1.30		0
	P3.06	Source of Safe Stop Command	Multi-command source mode (P1.39 = 1): Bit0: keyboard; Bit1: communication; Bit2: S1; Bit3: S2; ...		0
	P3.07	Reset command source			1
	P3.08	Source of fault command			0
	P3.09	Source of pause order			0
	P3.20	S1 type	0: positive logic; 1: Reverse logic; 2: Rising edge; 3: Falling edge;		0
	P3.21	S2 type			
	P3.22	S3 type			
	P3.23	S4 type			
	P3.24	S5 type			
	P3.25	S6 type			
	P3.26	S7 type			
	P3.27	S8 type			
	P3.28	S Input filtering	1~16		2
	P3.29	Start signal enable mode	0: always enabled; 1: need to re-enable after power on; 2: After free-stop or safe-stop, it needs to be re-enabled; 3: After power-on, free stop or safe stop, you need to re-enable		0
	P3.30	Y1 terminal source(RA、RB or RA1、RB1)	0: Always 0; 1: Always 1; 2: Stopped; 3: Running; 4: Fault; 5: Warning; 6: Reversing; 7: Ready; 64: STO state; 100 ~ 9999: address		3
	P3.31	Y1 terminal source Bit	0~31		0
P3.32	Y2 terminal source (RA2、RB2)	0: Always 0; 1: Always 1; 2: Stopped; 3: Running; 4: Fault; 5: Warning; 6: Reversing; 7: Ready;		4	

			64: STO state; 100 ~ 9999: address		
P3.33	Y2 terminal source bit		0~31		0
P3.34	Y3 terminal source (RA3 、 RB3 、 RC3)		0: Always 0; 1: Always 1; 2: Stopped; 3: Running; 4: Fault; 5: Warning; 6: Reversing; 7: Ready; 64: STO state; 100 ~ 9999: address		5
P3.35	Y3 terminal source Bit		0~31		0
P3.36	Y1 output delay time		0.000~6000.000	S	0.000
P3.37	Y2 output delay time				
P3.38	Y3 output delay time				
P3.39	A1 filter time		0.100~600.000	S	0.100
P3.40	A1 signal type		0: voltage input; 1: current input		0
P3.41	A1 low-end voltage (current)		-999999.000~999999.000	V(mA)	0.000
P3.42	A1 high-end voltage (current)				10.000
P3.43	A1 low-end setting		-999999.000~999999.000	%	0.000
P3.44	A1 high-end setting				100.000
P3.45	A2 signal type		0: voltage input; 1: current input		0
P3.46	A2 low-end voltage (current)		-999999.000~999999.000	V(mA)	0.000
P3.47	A2 high-end voltage (current)				10.000
P3.48	A2 low-end setting		-999999.000~999999.000	%	0.000
P3.49	A2 high-end setting				100.000
P3.60	AO1 signal type		0: voltage output; 1: current output		0

	P3.61	AO1 signal source	0: always 0; 1: Always 10V / 20mA; 2: Output frequency; 3: Motor current; 4: Output voltage; 5: Motor torque; 6: Output power; 7: Set frequency; 100 ~ 9999: quote the value of the parameter number		2
	P3.62	AO1 low-end setting	-999999.000~999999.000	%	0.000
	P3.63	AO1 high-end settings			50.000
	P3.64	AO1 low-end voltage (current)	-999999.000~999999.000	V(mA)	0.000
	P3.65	AO1 high-end voltage (current)			10.000
	P3.66	AO2 signal type	0: voltage output; 1: current output		
	P3.67	AO1 signal source	0: always 0; 1: Always 10V / 20mA; 2: Output frequency; 3: Motor current; 4: Output voltage; 5: Motor torque; 6: Output power; 7: Set frequency; 100 ~ 9999: quote the value of the parameter number		3
	P3.68	AO2 low-end setting	-999999.000~999999.000	%	0.000
	P3.69	AO2 high-end settings			50.000
	P3.70	AO2 low-end voltage (current)	-999999.000~999999.000	V(mA)	0.000
	P3.71	AO2 high-end voltage (current)			10.000
04	P4.00	PID proportional gain	0.000~10.000	%	0.010
	P4.01	PID integration time	0.001~9999.000	S	10.000
	P4.02	PID differential gain	0.000~9999.000	%	0.000
	P4.03	PID forward feedback coefficient	0~500	%	0
	P4.04	PID sampling time	0.001~9999.000	S	0.004
	P4.05	PID output upper limit	-1000.000~1000.000	%	100.000

: PID control	P4.06	PID output lower limit		%	0.000	
	P4.07	PID output filter time	0.000~600.000	S	0.000	
	P4.09	PID range	0.001~99999.000		100.000	
	P4.11	PID sleep frequency	0.000~500.000	%	0.000	
	P4.12	PID enters sleep time	0.000~3600.000	S	0.000	
	P4.13	PID wake-up deviation	0.000~100.000	%	0.000	
	P4.14	PID entry wake-up time	0.000~3600.000	S	0.000	
	P4.15	PID sleep action	0: do not sleep; 1: PID stop; 2: Slow down; 3: Free to stop; 4: Pause; 5: Lowest frequency operation			0
	P4.90	PID status	0~4294967295			
05 : System control	P5.00	Control mode	0: VF; 1: Open loop vector 1			1
	P5.06	Forward and reverse switching time	0.000~6000.000	S		0.000
	P5.07	Forced change direction	0: No effect; 1: forced change direction			0
	P5.08	Motor frequency upper limit	-1020.000~1020.000	Hz		55.000
	P5.10	Start function	0: Start frequency operation; 1: On speed start; 2: DC injection			0
	P5.11	Start Time	0.000~60000.000	S		0.000
	P5.12	Start frequency	0.000~100.000	Hz		0.000
	P5.14	On speed start mode	0: All directional; 1: Set value direction; 2~3: reserved			0
	P5.19	DC injection current	0.000~200.000	%		100.000
	P5.20	Stop function	Units: 0: free parking; 1: DC braking; Ten: 1: precise parking			0
	P5.21	Stop frequency	0.000~1000.000	Hz		0.000
	P5.22	DC braking current	0.000~150.000	%		100.000
	P5.23	DC braking time	0.000~1000.000	S		0.000
P5.24	Demagnetization time ratio	0.000~1000.000	%		10.000	
P5.26	Magnetic flux brake activation frequency	0.000~1000.000	Hz		0.000	

	P5.27	Magnetic Flux braking coefficient	100~200	%	100
	P5.28	Magnetic Flux braking time	0.000~1000.000	S	0.000
	P5.30	Brake resistance mode	0: invalid; 1: Maximum duty cycle;		1
	P5.50	Auto reset mode	0~9999		0
	P5.51	Auto reset time	0.000~600.000	S	10.000
	P5.60	Automatic energy saving minimum flux	30~100	%	100
	P5.61	Automatic energy saving start frequency	0.000~200.000	Hz	5.000
	P5.63	Manual energy-saving magnetic flux	30~90	%	70
	P5.71	Current limit	0~300	%	150
	P5.76	Upper limit of electric torque	0.000~900.000	%	150.000
	P5.77	Upper limit of regenerative torque	0.000~900.000	%	150.000
	P5.80	Over-voltage control	0: invalid; 1: valid at all times		1
	P5.82	Over-voltage control scale factor	0~200	%	100
	P5.83	Over-voltage control integral coefficient	1~10000	%	100
	P5.85	Under-voltage control	Units: grid power-down action mode 0: invalid; 1: Instant stop; 2: Safe parking; 3 ~ 6: reserved Tens: Under-voltage operation mode of power grid 0: invalid; 1: Safe frequency reduction		0
	P5.86	Power grid voltage level	100~800	V	*
	P5.90	AVR function selection	0: invalid; 1: valid; 2: Only invalid when decelerating		1
	P5.91	AVR function damping factor	0~400	%	100
06 : Motor model	P6.00	Motor parameter self-learning	0: invalid 1: Complete self-learning 2: Simple self-learning		0
	P6.05	Carrier frequency	2~16	kHz	*
	P6.06	Over-modulation	0: invalid; 1: valid		1

		function			
P6.10	Motor type	0: Asynchronous motor; 1: Surface mount permanent magnet synchronization; 2: Salient pole permanent magnet synchronization 4: single-phase motor			0
P6.11	Motor Power	0.000~100000.000	kW		*
P6.12	Motor voltage	0~1000	V		*
P6.13	Motor frequency	1~3000	Hz		*
P6.14	Motor current	0.00~1000.00	A		*
P6.15	Motor speed	10~65535	rpm		*
P6.16	Motor power factor	0.00~1.00			*
P6.17	Number of motor poles	2~100			*
P6.18	Motor rated torque	0.1~10000.0	NM		*
P6.19	Motor no-load current	0.00~1000.00	A		*
P6.20	PM motor back EMF / rev	1.000~1000.000	mV/rpm		*
P6.40	Stator impedance	0.000~99.990	Ω		*
P6.41	Rotor impedance	0.000~99.990	Ω		*
P6.42	Stator leakage reactance	0.000~999.990	mH		*
P6.44	Motor main reactance	0.00~999.90	mH		*
P6.50	PM d-axis reactance	0.000~1000.000	mH		*
P6.51	PM q-axis reactance	0.001~9999.000	mH		*
P6.52	PM d-axis reactance saturation coefficient	0.0~100.0	%		*
P6.53	PM q-axis reactance saturation coefficient	0.0~100.0	%		*
P6.54	PM d-axis reactance saturation coefficient	10~400	%		100
P6.55	PM q-axis reactance saturation coefficient	10~400	%		100
P6.60	Maximum field weakening current d	0.200 ~ 1.800			1.000

	P6.70	Load type	0: constant torque; 1: fan water pump; 2: promotion; 3: reserved		0
	P6.80	Motor cable compensation strength	0: low; 1: medium; 2: high		0
07 : Control algorithm	P7.50	Slip compensation	-500~500	%	100
	P7.51	Slip compensation filter constant	1~10000	%	100
	P7.52	Resonance suppression coefficient	0~10000	%	100
	P7.53	Low-speed suppression filter constant	1~10000	%	100
	P7.54	High-speed suppression filter constant	1~10000	%	100
	P7.55	Automatic torque boost coefficient	0~300	%	100
	P7.57	Low speed minimum current	0~300	%	50
	P7.58	Static friction lift coefficient	0~10000	%	100
	P7.59	Static friction lift time	0.0~1000.0	S	0.0
	P7.71	VF curve-F1	0~3000	Hz	50
	P7.72	VF curve-F2			50
	P7.73	VF curve-F3			50
	P7.74	VF curve-F4			50
	P7.75	VF curve-V0	0~10000	V	0
	P7.76	VF curve-V1			*
P7.77	VF curve-V2	*			
P7.78	VF curve-V3	*			
P7.79	VF curve-V4	*			
09 : System protect	P9.00	Input phase loss action	0: failure; 1: alarm; 2: invalid;		2
	P9.04	Output phase loss detection	0: invalid; 1: valid		1
	P9.06	ETR selection	0: invalid; 1: alarm; 2: fault		2
	P10.05	Software version number			
	P10.10	Control word	0~4294967295		
	P10.11	Set value	-65535.0~65535.0		

10 : Syst em statu s	P10.15	Current status	0~4294967295		
	P10.16	Fault status word 1	0~4294967295		
	P10.17	Fault status word 2	0~4294967295		
	P10.18	Alarm status word	0~4294967295		
	P10.20	Output frequency absolute value	0.0~65535.0	Hz	
	P10.21	Output frequency	-65535.0~65535.0	Hz	
	P10.22	Output current	0.00~65535.00	A	
	P10.23	Output voltage	0.0~65535.0	V	
	P10.24	Output torque	0.000~65535.000	NM	
	P10.25	DC voltage	0.0~65535.0	V	
	P10.26	Inverter temperature	0~65535	°C	
	P10.27	Inverter hot load	0~65535	%	
	P10.28	Motor hot load	0~65535	%	
	P10.30	power	0.000~65535.000	kW	
	P10.31	Energy consumption	0.000~4294967.295	kW*h	
	P10.40	Hours of power on	0.000~4294967.295	h	
	P10.41	Number of power-on	0~4294967295		
	P10.60	Current alarm number	0~4294967295		
	P10.61	Current fault number	0~4294967295		
	P10.62	Last fault number	0~4294967295		
	P10.63	The first two fault numbers	0~4294967295		
	P10.70	S input terminal status	0~4294967295		
	P10.71	AI1 terminal input value	-65535.000~65535.000	%	
	P10.72	AI2 terminal input value	-65535.000~65535.000	%	
	P10.74	Y terminal output status	0~4294967295		
	P10.75	AO1 terminal output value	-65535.000~65535.000	%	
	P10.76	AO2 terminal output value	-65535.000~65535.000	%	
	P10.78	Pulse input frequency	0.000~10000.000	kHz	
	P10.79	Pulse output frequency	0.000~10000.000	kHz	
	P10.80	Encoder count	0~4294967295		
	P10.81	Encoder speed	-9999.000~9999.000	Hz	
P10.82	Encoder angle	0.0~359.9	Deg		

	P10.90	Set value 1	-999999.000~999999.000	%	
	P10.91	Set value 2	-999999.000~999999.000	%	
	P10.92	Set value 3	-999999.000~999999.000	%	
	P10.98	Display value 1	-99999.000~99999.000		
	P10.99	Display value 2	-99999.000~99999.000		
11 : Fault list	P11.10	Present fault output frequency	-999999.0~999999.0	Hz	0.0
	P11.11	Present fault output current	-999999.00~999999.00	A	0.00
	P11.12	Present fault bus voltage	-999999.0~999999.0	V	0.0
	P11.13	Present faulty inverter temperature	-999999~999999	°C	0
	P11.14	Present fault X terminal status	-999999~999999		0
	P11.15	Present fault Y terminal status	-999999~999999		0
	P11.16	Accumulated power-on time	0.000~4294967.295	h	0.000
	P11.20	Output frequency of previous fault	-999999.0~999999.0	Hz	0.0
	P11.21	output current of Previous fault	-999999.00~999999.00	A	0.00
	P11.22	Bus voltage of previous fault	-999999.0~999999.0	V	0.0
	P11.23	Inverter temperature of previous fault	-999999~999999	°C	0
	P11.24	S-terminal status of previous fault	-999999~999999		0
	P11.25	Y terminal status of previous fault	-999999~999999		0
	P11.26	Accumulated power-on time of the previous fault	0.000~4294967.295	h	0.000
	P11.30	Output frequency of the 2rd faults	-999999.0~999999.0	Hz	0.0
	P11.31	The 2rd fault output currents	-999999.00~999999.00	A	0.00
	P11.32	Bus voltage of 2rd faults	-999999.0~999999.0	V	0.0
	P11.33	Inverter temperature of the 2rd faults	-999999~999999	°C	0
P11.34	S-terminal status of the 2rd faults	-999999~999999		0	
P11.35	The 2rd fault Y terminal status	-999999~999999		0	

	P11.36	Accumulated power-on time of the 2rd fault	0.000~4294967.295	h	0.000
12 : Free parameters	P12.00 ~ P12.19	Free parameter 1 ~ Free parameters 20	-999999.000~999999.000		0.000
	P12.90 ~ P12.99	Free parameter 91 ~ Free parameters 100	-999999.000~999999.000		0.000
13 : Function output	P13.00	Comparator output	0~4294967295		0
	P13.01	Logic output	0~4294967295		0
	P13.02	Linear transformation result 1	-999999.000~999999.000		0.000
	P13.03	Linear transformation result 2	-999999.000~999999.000		0.000
	P13.10	Single arithmetic operation 1 output	-999999.000~999999.000		0.000
	P13.11	Single arithmetic operation 2 output	-999999.000~999999.000		0.000
	P13.12	Single arithmetic operation 3 output	-999999.000~999999.000		0.000
	P13.13	Single arithmetic operation 4 output	-999999.000~999999.000		0.000
	P13.14	Single arithmetic operation 5 output	-999999.000~999999.000		0.000
	P13.15	Math operation 1 output	-999999.000~999999.000		0.000
	P13.16	Math operation 2 output	-999999.000~999999.000		0.000
	P13.17	Math operation 3 output	-999999.000~999999.000		0.000
	P13.18	Math operation 4 output	-999999.000~999999.000		0.000
	P13.40	Comparator output 1	0~1		0
	P13.41	Comparator output 2	0~1		0
	P13.42	Comparator output 3	0~1		0
	P13.43	Comparator output 4	0~1		0
	P13.44	Comparator output 5	0~1		0
	P13.45	Comparator output 6	0~1		0
P13.46	Comparator output 7	0~1		0	
P13.47	Comparator output 8	0~1		0	

	P13.48	Comparator output	9	0~1		0
	P13.50	Logic 1 output		0~1		0
	P13.51	Logic 2 output		0~1		0
	P13.52	Logic 3 output		0~1		0
	P13.53	Logic 4 output		0~1		0
	P13.54	Logic 5 output		0~1		0
	P13.60	currently counting of Timer 1		0~4294967295		0
	P13.61	Timer 1 current value		0~65535		0
	P13.62	Timer 1 current stage		0~16		0
	P13.63	Timer 2 is currently counting		0~4294967295		0
	P13.64	Timer 2 current value		0~65535		0
	P13.65	Timer 2 current stage		0~16		0
14 : Encoder	P14.01	Encoder resolution	1	1~2 ³¹		1024
	P14.02	Encoder 1 direction		0: forward; 1: reversed		0
16 : Logical unit	P16.00	Comparator 1 input parameter selection		0~65535		0
	P16.01	Comparator comparison parameter selection	1	0~65535		0
	P16.02	Comparator configuration	1	0:>; 1:<; 2:≥; 3:≤; 4:=; 5:≈; 6:≠		0
	P16.03	Comparator 2 delay time		0.000~600.000	s	0.000
	P16.04	Comparator 2 input parameter selection		0~65535		0
	P16.05	Comparator comparison parameter selection	2	0~65535		0
	P16.06	Comparator configuration	2	0:>; 1:<; 2:≥; 3:≤; 4:=; 5:≈; 6:≠		0
	P16.07	Comparator 2 delay time		0.000~600.000	s	0.000

P16.08	Comparator 3 input parameter selection	3	0~65535		0
P16.09	Comparator comparison parameter selection	3	0~65535		0
P16.10	Comparator configuration	3	0:>; 1:<; 2:≥; 3:≤; 4:=; 5:≈; 6:≠		0
P16.11	Comparator 3 delay time		0.000~600.000	s	0.000
P16.12	Comparator 4 input parameter selection	4	0~65535		0
P16.13	Comparator comparison parameter selection	4	0~65535		0
P16.14	Comparator configuration	4	0:>; 1:<; 2:≥; 3:≤; 4:=; 5:≈; 6:≠		0
P16.15	Comparator 4 delay time		0.000~600.000	s	0.000
P16.16	Comparator 5 input parameter selection	5	0~65535		0
P16.17	Comparator comparison parameter selection	5	0~65535		0
P16.18	Comparator configuration	5	0:>; 1:<; 2:≥; 3:≤; 4:=; 5:≈; 6:≠		0
P16.19	Comparator 5 delay time		0.000~600.000	s	0.000
P16.20	Comparator 6 input parameter selection	6	0~65535		0
P16.21	Comparator comparison parameter selection	6	0~65535		0
P16.22	Comparator configuration	6	0:>; 1:<; 2:≥; 3:≤; 4:=; 5:≈;		0

			6:≠		
P16.23	Comparator 6 delay time		0.000~600.000	s	0.000
P16.24	Comparator 7 input parameter selection		0~65535		0
P16.25	Comparator comparison parameter selection	7	0~65535		0
P16.26	Comparator configuration	7	0:>; 1:<; 2:≥; 3:≤; 4:=; 5:≈; 6:≠		0
P16.27	Comparator 7 delay time		0.000~600.000	s	0.000
P16.28	Comparator 8 input parameter selection		0~65535		0
P16.29	Comparator comparison parameter selection	8	0~65535		0
P16.30	Comparator configuration	8	0:>; 1:<; 2:≥; 3:≤; 4:=; 5:≈; 6:≠		0
P16.31	Comparator 8 delay time		0.000~600.000	s	0.000
P16.32	Comparator 9 input parameter selection		0~65535		0
P16.33	Comparator comparison parameter selection	9	0~65535		0
P16.34	Comparator configuration	9	0:>; 1:<; 2:≥; 3:≤; 4:=; 5:≈; 6:≠		0
P16.35	Comparator 9 delay time		0.000~600.000	s	0.000
P16.36	Logic unit parameter selection	1	0~65535		0

P16.37	Logic unit 1 input bit selection 1	0~32		0
P16.38	Logic unit 1 parameter selection 2	0~65535		0
P16.39	Logic unit 1 input bit selection 2	0~32		0
P16.40	Logic unit 1 parameter selection 3	0~65535		0
P16.41	Logic unit 1 input bit selection 3	0~32		0
P16.42	Logical unit configuration 1	0: No effect; 1: with; 2: OR; 3: NAND; 4: NOR; 5: XOR		0
P16.43	Logical unit configuration 2	0: No effect; 1: with; 2: OR; 3: NAND; 4: NOR; 5: XOR		0
P16.44	Logic unit 2 parameter selection 1	0~65535		0
P16.45	Logic unit 2 input bit selection 1	0~32		0
P16.46	Logic unit 2 parameter selection 2	0~65535		0
P16.47	Logic unit 2 input bit selection 2	0~32		0
P16.48	Logic unit 2 parameter selection 3	0~65535		0
P16.49	Logic unit 2 input bit selection 3	0~32		0
P16.50	Logical unit configuration 1	0: No effect; 1: with; 2: OR; 3: NAND; 4: NOR; 5: XOR		0
P16.51	Logical unit configuration 2	0: No effect; 1: with; 2: OR; 3: NAND; 4: NOR; 5: XOR		0
P16.76	Selector parameter source 1	0~65535		0

P16.77	Selector 1 setting		0~16		0
P16.78	Selector destination parameters	1	0~65535		0
P16.79	Selector parameter source	2	0~65535		0
P16.80	Selector 2 setting		0~16		0
P16.81	Selector destination parameters	2	0~65535		0
P16.82	Selector parameter source	3	0~65535		0
P16.83	Selector 3 setting		0~16		0
P16.84	Selector destination parameters	3	0~65535		0
P16.85	Selector parameter source	4	0~65535		0
P16.86	Selector 4 setting		0~16		0
P16.87	Selector destination parameters	4	0~65535		0
P16.88	Selector parameter source	5	0~65535		0
P16.89	Selector 5 setting		0~16		0
P16.90	Selector destination parameters	5	0~65535		0
P16.91	Selector parameter source	6	0~65535		0
P16.92	Selector 6 setting		0~16		0
P16.93	Selector destination parameters	6	0~65535		0
P16.94	Selector parameter source	7	0~65535		0
P16.95	Selector 7 setting		0~16		0
P16.96	Selector destination parameters	7	0~65535		0
P16.97	Selector parameter source	8	0~65535		0
P16.98	Selector 8 setting		0~16		0
P16.99	Selector destination parameters	8	0~65535		0
P17.00	Linear transformation parameter source	1	0~65535		0

17 : Math oper ation	P17.01	Linear transformation 1 X1	-999999.000~999999.000		0.000
	P17.02	Linear transformation 1 X2	-999999.000~999999.000		50.000
	P17.03	Linear transformation 1 Y1	-999999.000~999999.000		0.000
	P17.04	Linear transformation 1 Y2	-999999.000~999999.000		1500.000
	P17.05	Linear transformation 2 parameter source	0~65535		0
	P17.06	Linear transformation 2 X1	-999999.000~999999.000		0.000
	P17.07	Linear transformation 2 X2	-999999.000~999999.000		0.000
	P17.08	Linear transformation 2 Y1	-999999.000~999999.000		0.000
	P17.09	Linear transformation 2 Y2	-999999.000~999999.000		0.000
	P17.16	Single arithmetic operation 1 parameter source	0~65535		0
	P17.17	Single arithmetic operation 1 operation setting	0:ABS; 1:Sqrt; 2:Sin; 3:Cos; 4:power2; 5:Power3 6: random number		0
	P17.18	Single arithmetic operation 2 parameter source	0~65535		0
	P17.19	Single arithmetic operation 2 operation setting	0:ABS; 1:Sqrt; 2:Sin; 3:Cos; 4:power2; 5:Power3 6: random number		0
	P17.20	Single arithmetic operation 3 parameter source	0~65535		0
P17.21	Single arithmetic operation 3 operation setting	0:ABS; 1:Sqrt; 2:Sin; 3:Cos; 4:power2; 5:Power3 6: random number		0	
P17.22	Single arithmetic operation 4 parameter source	0~65535		0	

P17.23	Single arithmetic operation 4 operation setting	0:ABS; 1:Sqrt; 2:Sin; 3:Cos; 4:power2; 5:Power3 6: random number		0
P17.24	Single arithmetic operation 5 parameter source	0~65535		0
P17.25	Single arithmetic operation 5 operation setting	0:ABS; 1:Sqrt; 2:Sin; 3:Cos; 4:power2; 5:Power3 6: random number		0
P17.26	Mathematical operation 1 Parameter source 1	0~65535		0
P17.27	Mathematical operation 1 Parameter source 2	0~65535		0
P17.28	Mathematical operation 1 Parameter source 3	0~65535		0
P17.29	Math operation 1 Operation setting 1	0:No effect; 1:+; 2:- ; 3:*; 4/; 5:MAX; 6:Min; 7:Mean		0
P17.30	Math operation 1 Operation setting 2	0:No effect; 1:+; 2:- ; 3:*; 4/; 5:MAX; 6:Min; 7:Mean		0
P17.31	Mathematical operation 2 Parameter source 1	0~65535		0
P17.32	Mathematical operation 2 Parameter source 2	0~65535		0
P17.33	Mathematical operation 2 Parameter source 3	0~65535		0

P17.34	Math operation 2 Operation setting 1	0:No effect 1:+; 2:- ; 3:*; 4/; 5:MAX; 6:Min; 7:Mean		0
P17.35	Math operation 2 Operation setting 2	0:No effect; 1:+; 2:- ; 3:*; 4/; 5:MAX; 6:Min; 7:Mean		0
P17.36	Mathematical operation 3 Parameter source 1	0~65535		0
P17.37	Mathematical operation 3 Parameter source 2	0~65535		0
P17.38	Mathematical operation 3 Parameter source 3	0~65535		0
P17.39	Math operation 3 Operation setting 1	0:No effect; 1:+; 2:- ; 3:*; 4/; 5:MAX; 6:Min; 7:Mean		0
P17.40	Math operation 3 Operation setting 2	0:No effect; 1:+; 2:- ; 3:*; 4/; 5:MAX; 6:Min; 7:Mean		0
P17.41	Mathematical operation 4 Parameter source 1	0~65535		0
P17.42	Mathematical operation 4 Parameter source 2	0~65535		0
P17.43	Mathematical operation 4 Parameter source 3	0~65535		0

	P17.44	Math operation 4 Operation setting 1	0:No effect; 1:+; 2:-; 3:*; 4/; 5:MAX; 6:Min; 7:Mean		0
	P17.45	Math operation 4 Operation setting 2	0:No effect; 1:+; 2:-; 3:*; 4/; 5:MAX; 6:Min; 7:Mean		0
18 : Time r con trol	P18.00	Timer 1 clock source	0:1mS; 1:10mS; 2:100mS; 3:1S; 200~3799:Address		0
	P18.01	Timer 1 working mode	0: stop at the end of a single run; 1 ~ 16: Set the start of the next cycle		0
	P18.02	Timer 1 control commands	Bit0: enable; Bit1: Start counting; Bit2: pause counting; Bit3: Clear count		0
	P18.03	Timer 1 set value	-1~4294967295		-1
	P18.04	Timer 1 phase 1 time	0~4294967295		0
	P18.05	Timer 1 phase 2 time	0~4294967295		0
	P18.06	Timer 1 phase 3 time	0~4294967295		0
	P18.07	Timer 1 phase 4 time	0~4294967295		0
	P18.08	Timer 1 phase 5 time	0~4294967295		0
	P18.09	Timer 1 phase 6 time	0~4294967295		0
	P18.10	Timer 1 phase 7 time	0~4294967295		0
	P18.11	Timer 1 phase 8 time	0~4294967295		0
	P18.12	Timer 1 phase 9 time	0~4294967295		0
	P18.13	Timer 1 phase 10 time	0~4294967295		0
P18.14	Timer 1 phase 11 time	0~4294967295		0	

P18.15	Timer 1 phase 12 time	0~4294967295		0
P18.16	Timer 1 phase 13 time	0~4294967295		0
P18.17	Timer 1 phase 14 time	0~4294967295		0
P18.18	Timer 1 phase 15 time	0~4294967295		0
P18.19	Timer 1 phase 16 time	0~4294967295		0
P18.20	Timer 1 clock source	0:1mS; 1:10mS; 2:100mS; 3:1S; 200~3799:Address		0
P18.21	Timer 1 working mode	0: stop at the end of a single run; 1 ~ 16: Set the start of the next cycle		0
P18.22	Timer 1 control commands	Bit0: enable; Bit1: Start counting; Bit2: pause counting; Bit3: Clear count		0
P18.23	Timer 1 set value	-1~4294967295		-1
P18.24	Timer 1 phase 1 time	0~4294967295		0
P18.25	Timer 1 phase 2 time	0~4294967295		0
P18.26	Timer 1 phase 3 time	0~4294967295		0
P18.27	Timer 1 phase 4 time	0~4294967295		0
P18.28	Timer 1 phase 5 time	0~4294967295		0
P18.29	Timer 1 phase 6 time	0~4294967295		0
P18.30	Timer 1 phase 7 time	0~4294967295		0
P18.31	Timer 1 phase 8 time	0~4294967295		0
P18.32	Timer 1 phase 9 time	0~4294967295		0
P18.33	Timer 1 phase 10 time	0~4294967295		0
P18.34	Timer 1 phase 11 time	0~4294967295		0
P18.35	Timer 1 phase 12 time	0~4294967295		0
P18.36	Timer 1 phase 13 time	0~4294967295		0
P18.37	Timer 1 phase 14 time	0~4294967295		0

	P18.38	Timer 1 phase 15 time	0~4294967295		0
	P18.39	Timer 1 phase 16 time	0~4294967295		0

01 parameters: system configuration

Parameter NO.	Parameter Name	Setting range	Unit	Factory value
P1.11	Parameter operation	0: normal operation; 1: Parameter initialization, initialize all parameters except P1.XX and application macro; 2: Initialize all parameters;		0
P1.13	Set keyword	0~9999		0
P1.14	Set keyword confirmed	0~9999		0
P1.15	Input keyword	0~9999		0

- Function:Parameter operation setting

➤ **Principle explanation:**

Set P1.13 and P1.14 to the same non-zero number, and the set password is valid.

Parameter NO.	Parameter Name	Setting range	Unit	Factory value
P1.20	Apply macro	0~9999		0
P1.21	Formula	0~10000		0

- Function:** choose application macro, formula

Principle explanation:

Application macro is a group of parameter. Activating the corresponding application macro is same to setting the macro parameter set.

Set P1.20 to select the corresponding macro, you can select 2 macros at the same time. Each two-digit number represents a macro, thousand bit and hundred bit form a macro, and ten bit and unit form another macro. When the corresponding macro setting value of P1.20 changes, the corresponding macro configuration action is applied, and any parameters can be manually modified after the configuration is completed. For specific macro information, please refer to the application macro detailed description.

A formula is a set of parameter sets, and the corresponding formula configuration action is executed every time the power is turned on and switched.

Parameter NO.	Parameter Name	Setting range	Unit	Factory value
P1.30	virtual terminal to set	0~199:Value setting; 200~9999:Address		0

- Function:**virtual terminal to set

□ **Principle explanation:**

The virtual terminal is used as a function extension. When set to 0 ~ 199, this value is the set value; when set to 200 ~ 9999, this setting is the address. The address is the selected parameter number, and the actual value is determined by the current value of the selected parameter number. For usage details, please refer to P3.00 ~ P3.09.

Parameter NO.	Parameter Name	Setting range	Unit	Factory value
P1.39	Command Mode	0:Single Command source mode; 1:Multi-command source mode		0

- Function:Select command mode!

Principle explanation:

The command mode determines the command source . The single-command source mode specifies one source with an index number, and the multi-command source mode can specify multiple sources in binary. For usage details, please refer to P3.00 ~ P3.09.

Parameter NO.	Parameter Name	Setting range	Unit	Factory value
P1.40	Communication Protocol	0:Reserved; 1:MODBUS RTU; 2-6:Reserved		1

- Function:Select communication protocol (only supports MODBUS RTU)

Parameter NO.	Parameter Name	Setting range	Unit	Factory value
P1.41	Address	0~247		1

- Function:Set the local address of the inverter

Parameter NO.	Parameter Name	Setting range	Unit	Factory value
P1.42	Baud Rate	0:2400; 1:4800; 2:9600; 3:19200; 4:38400; 5~10:Reserved	Bps	3
P1.43	Parity Check	0:No Check; 1:Even check; 2:Odd check		0
P1.44	Data Bit	8~9	Bits	8
P1.45	Stop Bit	0.0~2.0	Bit	1.0

- Function:Communication port configuration

Parameter NO.	Parameter Name	Setting range	Unit	Factory value
P1.47	parameter decimal mode	0 ~ 123 Ones place: 0: Decimal place remains unchanged, 1: The number of decimal places becomes two, 2: The decimal place becomes one, 3: Become no decimal places; Tens place: 0: Decimal place remains unchanged, 1: The decimal place becomes one, 2: Become no decimal places; Hundreds: 0: The decimal place remains unchanged, 1: Become no decimal places		0

- Function:Adjust parameter decimal places

Principle explanation:

The parameter decimal point mode only affects communication, changes the parameter value during communication.

P1.47's unit place are for the parameters of three decimal places: 0: the decimal place remains unchanged, 1: the decimal place becomes two, 2: the decimal place becomes one, 3: becomes no decimal place.

The ten place of P1.47 are for the parameters of two decimal places: 0: the decimal place remains unchanged, 1: the decimal place becomes one, 2: becomes no decimal place.

P1.47's hundred place are for one decimal place parameter: 0: decimal place remains unchanged, 1: becomes no decimal place.

For example: 2.51 = 30.000s, when 1.47 = 000, serial port read data = 30000; when 1.47 = 001, serial port read data = 3000; when 1.47 = 002, serial port read data = 300; when 1.47 = 003, Serial port reading data = 30.

For example: 6.44 = 43.66, when 1.47 = 000, serial port read data = 4366; when 1.47 = 010, serial port read data = 436; when 1.47 = 020, serial port read data = 43

Parameter NO.	Parameter Name	Setting range	Unit	Factory value
P1.63	Keyboard settings source	0: Keyboard numeric setting (P2.92); 1: Keyboard potentiometer setting		1

- Function:Set keyboard settings source

Principle explanation:

Select the source of keyboard setting value, digital setting (P2.92) or keyboard potentiometer.

When the keyboard potentiometer setting is selected, P2.92 will keep the current potentiometer setting data, then select the keyboard numeric setting, and set the frequency to the previous potentiometer setting data.

Parameter NO.	Parameter Name	Setting range	Unit	Factory value
P1.66	keyboard M light Source	0: always 0; 1: always 1; 2: stopped; 3: running; 4: fault; 5: Warning; 6: Reversing; 7: ready; 64: STO state; 100 ~ 9999: address		5
P1.67	Keyboard M Lamp source Bit display	0~31		0

- Function: Select the signal source of the keyboard M light

Principle explanation:

The set value of keyboard M light source is bigger or equal to 100 (address mode), the address is the selected parameter number, the actual value is determined by the current value of the selected parameter number. The bit position of the keyboard M light source is set bit selection. When the terminal source is address 100 ~ 9999, the bit setting is valid. The keyboard M light source setting value is less than 100 (non-address mode), and the keyboard M light source bit does not need to be set. The function description of the terminal source is as follows:

Setting value	Function	Description
0	Always 0	Keyboard M light off
1	Always 1	Keyboard M lights up
2	stopped	The keyboard M light is on in the stopped state
3	running	The keyboard M light is on in the running state
4	Fault	The keyboard M light is on in the fault state
5	Warning	Keyboard M light is on in warning state
6	Reversing	The keyboard M light is on in the reverse state
7	Ready	The keyboard M light is on in the ready state
64	STO status	The keyboard M light is on in the STO state,
100~9999	address	Select the parameter as the keyboard M light output source

Parameter NO.	Parameter Name	Setting range	Unit	Factory value
P1.68	value 1 source	0-9999		1011(P10.11)
P1.69	value 2 source	0-9999		1091(P10.91)

- Function: Set display value source

□ Principle explanation:

Set the source of the display value, the source is the parameter number, and the value of the corresponding parameter number is put into P10.98 and P10.99 to be used as the corresponding monitoring display of the keyboard. See the keyboard description for details.

The keyboard display value 1 and display value 2 can be flexibly selected, and the factory value displays the set value and set value 2. If want to select other status data display, set P1.68 and P1.69 to the corresponding parameter number, for example: the keyboard displays acceleration time 0 and acceleration time 1, you need to set the parameters P1.68 = 250, P1.69 = 251, at this time, the data of the keyboard display value 1 is the acceleration time 0, and the data of the display value 2 is the acceleration time 1.

02 parameters: setting channels

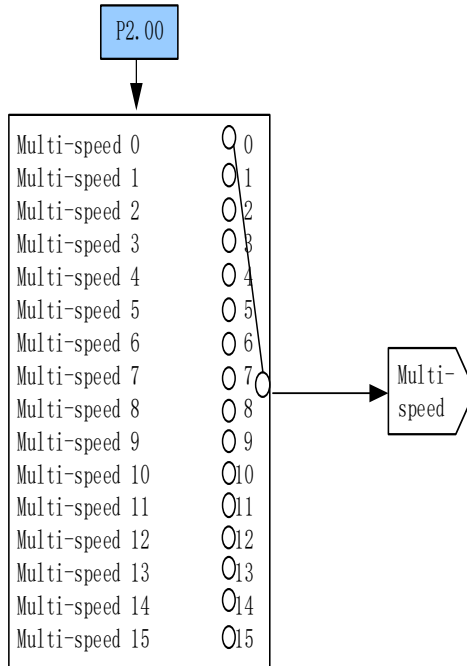

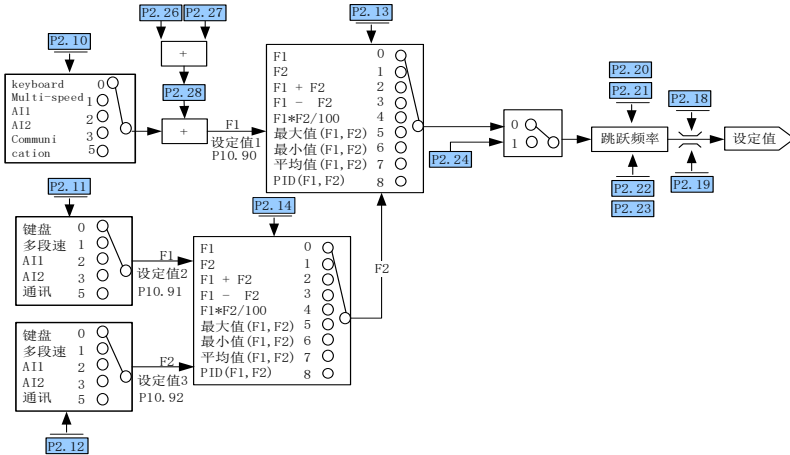

Figure 6-2-1 Set value source and channel setting

Parameter NO.	Parameter Name	Setting range	Unit	Factory value
P2.00	Multi-speed source	0~11111111		0
P2.01	Source of acceleration time	Units: S1; Tens: S2; Hundreds: S3; ...		0
P2.02	Source of deceleration time	...		0
P2.03	Source of incremental instruction (UP)	Units: keyboard; Tens: communication; Hundreds: S1; Thousands: S2; ...		0
P2.04	Source of Decrement instruction (DOWN)	...		0

- Function: Select command source

P2.00: Multi-speed source, select the corresponding external terminal, see P2.30 ~ P2.45 for multispeed 0 ~ 15.

P2.01: Source of acceleration time, select the corresponding external terminal. For acceleration time, please refer to P2.50 ~ P2.65.

P2.02: source of deceleration time, select the corresponding external terminal, see P2.70 ~ P2.85 for deceleration time.

P2.03: Source of incremental instruction (UP), select the corresponding source.

P2.04: Decrease instruction (DOWN) source, select the corresponding source. See P2.26 ~ P2.28 for UP / DOWN parameters.

Example: Select S2, S3, S4 as effective external terminals to control 8-stage speed:

Step 1: Select S2, S3, S4 as multi-speed terminals, P2.00 is set to 1110;

Step 2: Control S2, S3, S4 to switch multi-speed, the corresponding relationship between 8 multi-speed is as follows:

Table 6-2-1

S4	S3	S2	Effective multi-speed
0	0	0	Multi-speed 0
0	0	1	Multi-speed 1
0	1	0	Multi-speed 2
0	1	1	Multi-speed 3
1	0	0	Multi-speed 4
1	0	1	Multi-speed 5
1	1	0	Multi-speed 6
1	1	1	Multi-speed 7

Parameter NO.	Parameter Name	Setting range	Unit	Factory value
P2.10	Set value source 1	0: keyboard; 1: Multi-speed; 2: AI1; 3: AI2; 5: communication; 9: pulse input 200 ~ 9999: address		0
P2.11	Set value source 2			0
P2.12	Set value source 3			0

- Function: Select the source of the set value

- See P1.63 for keyboard setting value.
- The communication setting value is written into P2.90 through communication.
- When the setting is 200 ~ 9999, this setting is the address. The address is the selected parameter number, and the actual value is determined by the current value of the selected parameter number.

Parameter NO.	Parameter Name	Setting range	Unit	Factory value
P2.13	Set channel 1 relationship selection	0:F1; 1:F2; 2:F1+F2; 3:F1-F2; 4:F1*F2/100; 5:Maximum value(F1,F2); 6:Minimum value(F1,F2); 7:Average value(F1,F2); 8:PID(F1,F2);		0
P2.14	Set channel 2 relationship selection			0

- Function: Select to set the channel relationship

Principle explanation:

In the setting channel relationship, set 0 to select the F1 channel set value; Set 1 to select the F2 channel set value; Set 2 to select the sum of the F1 and F2 channel set values; Set 3 to select the difference between the F1 and F2 channel set values ; Set 4 to select the product of F1 and F2 channel set value divided by 100; Set 5 to select the maximum value in F1 and F2; Set 6 to select the minimum value in F1 and F2; Set 7 to select the average value of F1 and F2; Set 8 to select PID Control (F1 is set, F2 is feedback).

Parameter NO.	Parameter Name	Setting range	Unit	Factory value
P2.18	Maximum setting	-99999.000~99999.000		50.000
P2.19	Minimum setting			0.000

- Function: limit the set value range

Principle explanation:

Limit the setting range to [P2.19, P2.18]. When each setting source is in units of %, the maximum setting value (P2.18) represents 100%, which is based on the maximum setting value. The output frequency is less than or equal to P5.08 motor frequency upper limit.

Parameter NO.	Parameter Name	Setting range	Unit	Factory value
P2.20	Avoid-frequency 1 start point	-1000.000~1000.000	%	0.000
P2.21	Avoid-frequency 1 stop point			
P2.22	Avoid-frequency 2 start point			
P2.23	Avoid-frequency 2 stop point			

- Function: Set the avoidance frequency

Principle explanation:

The set frequency of the inverter is given in a skipped manner in the avoidance frequency range in the manner of Figure 6-2-2.

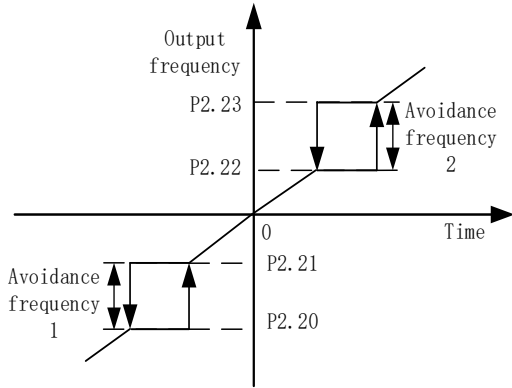

Figure 6-2-2 Frequency of avoidance

Parameter NO.	Parameter Name	Setting range	Unit	Factory value
P2.24	Jog frequency	-1000.000~1000.000	%	10.000

- Function: Set the Jog frequency as a percentage of the maximum set value of P2.18. Jog command see P3.03

Parameter NO.	Parameter Name	Setting range	Unit	Factory value
P2.26	Increase and decrease (UP / DOWN) Step-frequency	-100.0~100.0	%	0.2
P2.27	Increase and decrease (UP / DOWN) memory selection	0: no memory; 1: Only power down memory; 2: Only stop memory; 3: Both power down and stop memory		3
P2.28	Speed up and down frequency	-1000.000~1000.000	%	0.000

- Function: Select UP / DOWN function

Principle explanation:

When the signal is activated, the frequency setting of the inverter increases or decreases by one unit. When the switch is held, the frequency will rapidly increase upward or downward to a certain time, and then increase or decrease uniformly. See P2.03 ~ P2.04 for the selection of UP / DOWN signal. P2.28 is only used for clearing UP / DOWN results. The data has no intuitive meaning after standardization.

Parameter NO.	Parameter Name	Setting range	Unit	Factory value
P2.30	Multi-speed 0	-1000.000~1000.000	%	0.000
P2.31	Multi-speed 1			
P2.32	Multi-speed 2			
P2.33	Multi-speed 3			
P2.34	Multi-speed 4			
P2.35	Multi-speed 5			
P2.36	Multi-speed 6			
P2.37	Multi-speed 7			
P2.38	Multi-speed 8			
P2.39	Multi-speed 9			
P2.40	Multi-speed 10			
P2.41	Multi-speed 11			
P2.42	Multi-speed 12			
P2.43	Multi-speed 13			
P2.44	Multi-speed 14			
P2.45	Multi-speed 15			

- Function: Multi-stage speed setting

Parameter NO.	Parameter Name	Setting range	Unit	Factory value
P2.50	Accelerate time 0	0.050~3600.000	S	*
P2.51	Accelerate time 1			
P2.52	Accelerate time 2			
P2.53	Accelerate time 3			
P2.54	Accelerate time 4			
P2.55	Accelerate time 5			
P2.56	Accelerate time 6			
P2.57	Accelerate time 7			
P2.58	Accelerate time 8			
P2.59	Accelerate time 9			
P2.60	Accelerate time 10			
P2.61	Accelerate time 11			
P2.62	Accelerate time 12			
P2.63	Accelerate time 13			

P2.64	Accelerate time 14			
P2.65	Accelerate time 15			

- Function: acceleration time setting

Principle explanation:

As shown in Figure 6-2-3, the acceleration time refers to the time required to accelerate from 0Hz to P6.13 motor frequency.

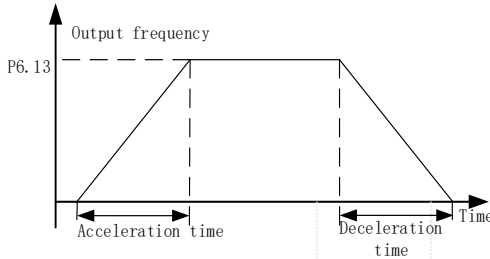

Figure 6-2-3 Acceleration and deceleration

Parameter NO.	Parameter Name	Setting range	Unit	Factory value
P2.66	Jog acceleration time	0.050~3600.000	S	5.000

- Function: Set Jog acceleration time

Parameter NO.	Parameter Name	Setting range	Unit	Factory value
P2.68	S curve acceleration time 1	0.000~100.000	%	0.000
P2.69	S curve acceleration time 2			

- Function: Set S curve acceleration time

Principle explanation:

S-curve acceleration is relatively smooth. When the reference frequency is approached, the acceleration is automatically adjusted to avoid exceeding the rated frequency of the motor.

Note: When P2.68 and P2.89 are not 0, S curve acceleration and deceleration are effective.

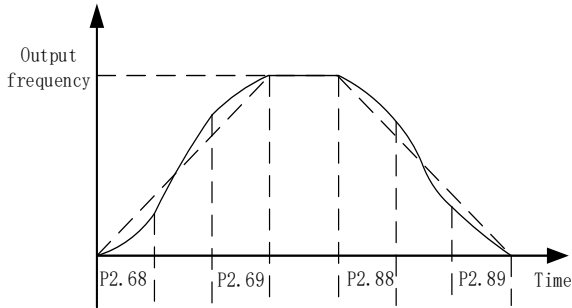

Figure 6-2-4 S curve acceleration and deceleration

Parameter NO.	Parameter Name	Setting range	Unit	Factory value
P2.70	Deceleration time 0	0.050~3600.000	S	*
P2.71	Deceleration time 1			
P2.72	Deceleration time 2			
P2.73	Deceleration time 3			
P2.74	Deceleration time 4			
P2.75	Deceleration time 5			
P2.76	Deceleration time 6			
P2.77	Deceleration time 7			
P2.78	Deceleration time 8			
P2.79	Deceleration time 9			
P2.80	Deceleration time 10			
P2.81	Deceleration time 11			
P2.82	Deceleration time 12			
P2.83	Deceleration time 13			
P2.84	Deceleration time 14			
P2.85	Deceleration time 15			

- Function: Set deceleration time

□ Principle explanation:

As shown in Figure 6-2-3, the deceleration time refers to the time required to decelerate from P6.13 motor frequency to 0Hz.

Parameter NO.	Parameter Name	Setting range	Unit	Factory value
---------------	----------------	---------------	------	---------------

P2.86	Jog deceleration time	0.050~3600.000	S	5.000
P2.87	Safe deceleration time			

- Function: Set Jog deceleration time and safe deceleration time (Jog command see P3.03, safe stop command see P3.06)

Parameter NO.	Parameter Name	Setting range	Unit	Factory value
P2.88	S curve deceleration time 1	0.000~100.000	%	0.000
P2.89	S curve deceleration time 2			

- Function: Set S curve deceleration time (see P2.68, P2.69)

Parameter NO.	Parameter Name	Setting range	Unit	Factory value
P2.90	Communication set value	-1000.000~1000.000	%	0.000
P2.91	Communication demand	0~4294967295(16 Hex)		0
P2.92	Keyboard set value	-1000.000~1000.000	%	100.000
P2.93	Keyboard demand	0~4294967295(16 Hex)		0

- Function: port between control command and set value, no need to set under normal circumstances, can be used for viewing

Table 6-2-2 Command control word table

Command word (Bit)	Definition
0	start up
1	Reverse
2	Start reverse
3	JOG
4	stop
5	Emergency stop
6	Safe stop
7	Reset
9	Parameter self-learning
10	Jump
11	pause
13	UP (incremental)
14	DOWN (decreasing)

03 parameters: input and output

Reverse start-command: set value is reversed, and start-command is send.

Parameter NO.	Parameter Name	Setting range	Unit	Factory value	
P3.00	Start command source	0 ~ 4294967295 Single command source mode (P1.39 = 0): 0: No effect; 1: keyboard; 2: communication; 3: S1; 4: S2 ... 17 ~ 32: The 0 ~ 15 bits of P1.30		1	
P3.01	Reverse start command source			0	
P3.02	Reverse command source			0	
P3.03	Jog command source			1	
P3.04	Source of stop command			0	
P3.05	Free parking order source			0	
P3.06	Source of Safe Stop Command			Multi-command source mode (P1.39 = 1): Bit0: keyboard; Bit1: communication; Bit2: S1; Bit3: S2; ...; Bit16 ~ Bit31: The 0 ~ 15 bits of P1.30	0
P3.07	Reset command source				1
P3.08	Source of fault command				0
P3.09	Source of pause order				0

- Function: Select the command source (when the corresponding command source is selected as the keyboard, the reverse command, Jog command, and free stop command are all derived from the custom key M)

Reverse command: set value is reversed.

Jog command: Jog function. The priority is greater than the start command and lower than the stop command.

Safe stop: stop according to the safe deceleration time (P2.87). The priority is higher than the stop command and lower than the free stop command.

Fault command: send out a fault signal and the inverter will stop freely.

Pause command: The inverter stops freely, but the operating bit in the status word remains.

Principle explanation:

P1.39 = 0 is single command source mode, P3.00 ~ P3.09 commands select a single source, index number 0: no effect; 1: keyboard; 2: communication,.... For example, when P3.00 = 3, the start command comes from S1. The operation of the host computer needs to select communication, and the single command function is effective.

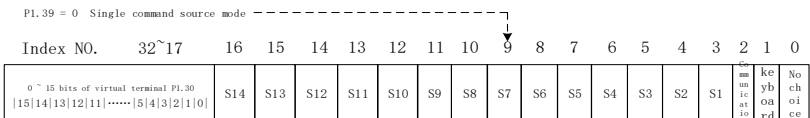

Figure 6-3-1 Single command source mode

P1.39 = 1 is multi-command source mode, P3.00 ~ P3.09 commands can select multiple sources, set bit selection bit0: keyboard, bit1: communication, For example, when P3.00 = 7 (binary 111), there are three ways to start the command source, which are keyboard, communication, and S1. The operation of the host

computer needs to select communication, and the multi-command function is effective.

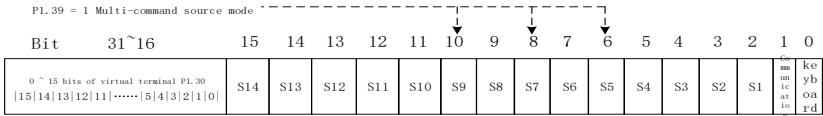

Figure 6-3-2 Multi-command source mode

Parameter NO.	Parameter Name	Setting range	Unit	Factory value
P3.20	S1 type	0: positive logic; 1: Reverse logic; 2: Rising edge; 3: Falling edge;		0
P3.21	S2 type			
P3.22	S3 type			
P3.23	S4 type			
P3.24	S5 type			
P3.25	S6 type			
P3.26	S7 type			
P3.27	S8 type			

- Function: select external terminal trigger type

Principle explanation:

- 0: positive logic, high level is valid state, low level is invalid state;
- 1: reverse logic, high level is invalid state, low level is valid state;
- 2: rising edge, rising edge is valid;
- 3: Falling edge, falling edge is valid.

Two-wire mode 1:

This mode is the most commonly used two-wire mode with enable and direction in one. The switch signals K1 and K2 determine the forward and reverse rotation of the motor.

Table 6-3-1

Parameter No	Setting value	Note
P3.00	3	The source of the start command is S1
P3.01	4	The source of the reverse start command is S2
P3.20	0	S1 type is positive logic
P3.21	0	S2 type is positive logic

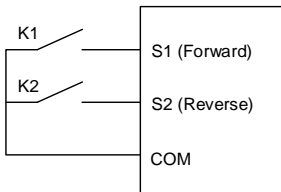

K1	K2	Operate command
OFF	OFF	Stop
OFF	ON	Reverse
ON	OFF	Forward
ON	ON	Stop

6-3-3

Two-wire mode 2:

The enable is separated from the direction. In this mode, K1 is the running enable terminal, and the

direction is determined by K2.

Table 6-3-2

Parameter No	Setting value	Note
P3.00	3	The source of the start command is S1
P3.02	4	The source of the reverse start command is S2
P3.20	0	S1 type is positive logic
P3.21	0	S2 type is positive logic

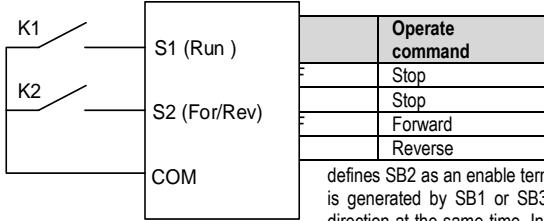

Figure 6-3-4
Three-wire control mode 1:

This mode defines SB2 as an enable terminal, the running command is generated by SB1 or SB3, and controls the running direction at the same time. Inverter operation SB2 is in a

closed state, and terminal SB1 or SB2 generates a rising edge signal to control the inverter operation and direction; when the inverter stops, it is necessary to disconnect terminal SB2 to complete the shutdown.

Table 6-3-3

Parameter No	Setting value	Note
P3.00	3	The source of the start command is S1
P3.01	5	The source of the reverse start command is S3
P3.04	4	The source of the stop command is S2
P3.20	2	S1 type is rising edge
P3.21	1	S2 type is reverse logic
P3.22	2	S3 type is rising edge

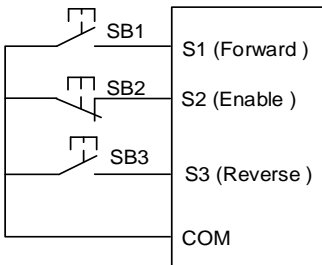

figure 6-3-5

Three-wire control mode 2:

This mode defines SB2 as an enable terminal, the run command is generated by button SB1, and the direction command is controlled by switch K. When the inverter is running, terminal SB2 needs to be in the closed state. Terminal SB1 generates a rising edge signal. The inverter starts to run. The state of switch K determines the running direction. When the inverter stops, terminal SB2 needs to be disconnected to complete the shutdown.

Table 6-3-4

SB1	SB2	SB3	Operate command
—	0	—	Stop
↑	1	—	Forward
—	1	↑	Reverse

G

Parameter No	Setting value	Note
P3.00	3	The source of the start command is S1
P3.02	5	The source of the reverse start command is S3
P3.04	4	The source of the stop command is S2
P3.20	2	S1 type is rising edge
P3.21	1	S2 type is reverse logic
P3.22	0	S3 type is rising edge

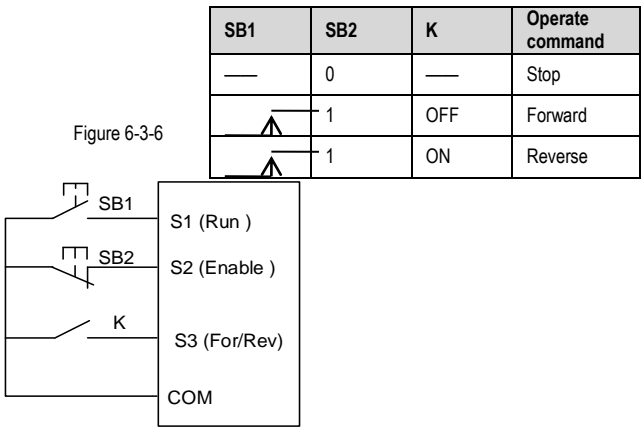

Parameter NO.	Parameter Name	Setting range	Unit	Factory value
P3.28	S Input filtering	1 ~ 16		2
P3.29	Start signal enable mode	0: always enabled; 1: need to re-enable after power on; 2: After free-stop or safe-stop, it needs to be re-enabled; 3: After power-on, free stop or safe stop, you need to re-enable		0

- Function: Control S terminal input effect and enable mode

S input filtering: S input signal is filtered, the larger the parameter value setting, the more obvious the filtering effect.

Start signal enable mode: When the start command comes from the external terminal, the safety of the inverter is improved.

Set parameter P3.29 to 0. During power-up, the inverter detects that the start command terminal is valid, and the inverter starts immediately.

Set parameter P3.29 to 1. During power-up, even if the inverter detects that the start command terminal is valid, the inverter will not start. Only when the terminal is re-enabled, the inverter can start.

Set parameter P3.29 to 2. After free stop or safe stop, even if the inverter detects that the start command terminal is valid, the inverter will not start. Only the terminal terminal is enabled again, the inverter can start.

Set parameter P3.29 to 3, the terminal needs to be re-enabled after power-on, free stop or safe stop before the inverter can start.

Parameter NO.	Parameter Name	Setting range	Unit	Factory value
P3.30	Y1 terminal source(RA、RB 或 RA1、RB1)	0: Always 0; 1: Always 1; 2: Stopped; 3: Running; 4: Fault; 5: Warning; 6: Reversing; 7: Ready; 64: STO state; 100 ~ 9999: address		3
P3.31	Y1 terminal source Bit	0~31		0
P3.32	Y2 terminal source (RA2、RB2)	0: Always 0; 1: Always 1; 2: Stopped; 3: Running; 4: Fault; 5: Warning; 6: Reversing; 7: Ready; 64: STO state; 100 ~ 9999: address		4
P3.33	Y2 terminal source bit	0~31		0
P3.34	Y3 terminal source (RA3、RB3、RC3)	0: Always 0; 1: Always 1; 2: Stopped; 3: Running; 4: Fault; 5: Warning; 6: Reversing; 7: Ready; 64: STO state; 100 ~ 9999: address		5
P3.35	Y3 terminal source Bit	0~31		0

- Function: Select the signal source of the digital output terminal

Principle explanation:

The terminal source setting value is greater than or equal to 100 (address mode), the address is the selected parameter number, and the actual value is determined by the current value of the selected parameter number. Bit source of terminal source is set bit selection. When terminal source is address 100 ~ 9999, the bit setting is valid. The terminal source setting value is less than 100 (non-address mode), and the terminal source Bit need not be set The function description of the terminal source is as follows:

Table 6-3-5

Parameter No	Setting value	Note
0	Always 0	Y terminal output is always 0
1	Always 1	Y terminal output is always 1
2	stopped	In the stopped state, Y terminal output is 1
3	running	In the running state, Y terminal output is 1
4	Fault	In the fault state, Y terminal output is 1

5	Warning	In the warning state, Y terminal output is 1
6	Reversing	In reverse state, Y terminal output is 1
7	Ready	In the ready state, Y terminal output is 1
64	STO status	In STO state, Y terminal output is 1
100-9999	address	Select parameters as Y output source

Parameter NO.	Parameter Name	Setting range	Unit	Factory value
P3.36	Y1 output delay time	0.000~6000.000	S	0.000
P3.37	Y2 output delay time			0.000
P3.38	Y3 output delay time			0.000

- Function: Set Y1, Y2, Y3 output delay time

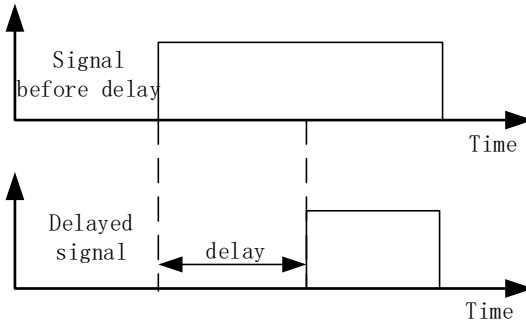

Figure 6-3-7 Y output delay

Parameter NO.	Parameter Name	Setting range	Unit	Factory value
P3.39	AI filter time	0.100~600.000	S	0.100

- Function: Set AI filter time

Principle explanation:

Adjust the sensitivity of the analog input, and increase the value appropriately to enhance the anti-interference of the analog, but it will reduce the sensitivity of the analog input.

Parameter NO.	Parameter Name	Setting range	Unit	Factory value
P3.40	AI1 signal type	0: voltage input; 1: current input		0
P3.41	AI1 low-end voltage (current)	-999999.000~999999.000	V(mA)	0.000

P3.42	AI1 high-end voltage (current)		10.000
P3.43	AI1 low-end setting		% 0.000

▪ Function: Analog input AI1 setting

- AI1 signal type: select input signal type, set value is 0, voltage signal input; set value is 1, current signal input.
- AI1 low-end voltage (current): set the minimum voltage (current) of the input signal.
- AI1 high-end voltage (current): set the maximum voltage (current) of the input signal.
- AI1 low-end setting: set the corresponding value of low-end voltage (current).
- AI1 high-end setting: set the corresponding value of high-end voltage (current).

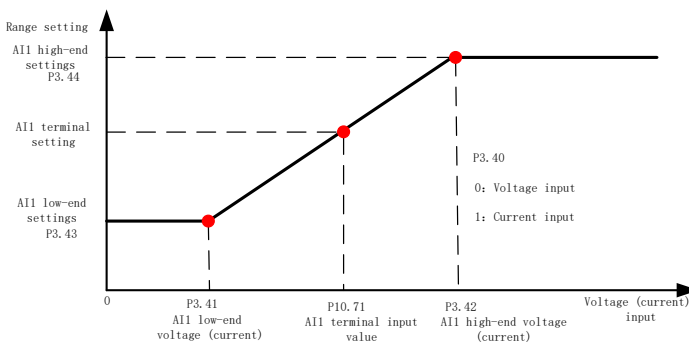

Figure 6-3-8 AI setting

Parameter NO.	Parameter Name	Setting range	Unit	Factory value
P3.45	AI2 signal type	0: voltage input; 1: current input		0
P3.46	AI2 low-end voltage (current)	-999999.000~999999.000	V(mA)	0.000
P3.47	AI2 high-end voltage (current)			10.000
P3.48	AI2 low-end setting		%	0.000
P3.49	AI2 high-end setting			100.000

▪ Function: Analog input AI2 setting

□ For details, please refer to P3.40 ~ P3.44.

Parameter NO.	Parameter Name	Setting range	Unit	Factory value
P3.60	AO1 signal type	0: voltage output; 1: current output		0

P3.61	AO1 signal source	0: always 0; 1: Always 10V / 20mA; 2: Output frequency; 3: Motor current; 4: Output voltage; 5: Motor torque; 6: Output power; 7: Set frequency; 100 ~ 9999: quote the value of the parameter number		2
P3.62	AO1 low-end setting	-999999.000~999999.000	%	0.000
P3.63	AO1 high-end settings			50.000
P3.64	AO1 low-end voltage (current)		V(mA)	0.000
P3.65	AO1 high-end voltage (current)			10.000

- Function: Analog output AO1 setting

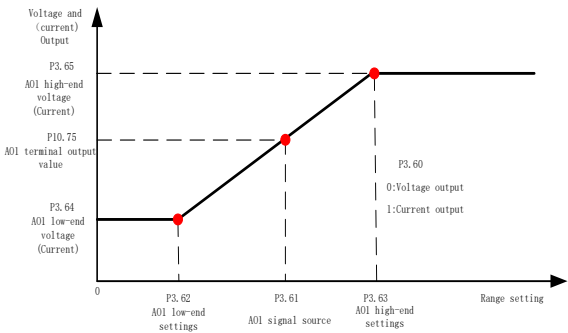

Figure 6-3-9 AO setting

AO1 signal type: select the output signal type, set value is 0, voltage signal output; set value is 1, current signal output.

AO1 signal source: select the signal source of AO output, 0: always 0; 1: always 10V / 20mA; 2: output frequency; ...

AO1 low-end setting: set the minimum value of AO1 source.

AO1 high-end setting: set the maximum value of AO1 source.

AO1 low-end voltage (current): set the minimum voltage (current) of the output signal.

AO1 high-end voltage (current): set the maximum high-end voltage (current) of the output signal.

Principle explanation:

As shown in Fig. 6-3-9, set the AO1 signal source, check the P10.75 (AO1 terminal output value) of the AO1 terminal output value, or measure with a multimeter. The function description of AO1 signal source is as

follows:

Table 6-3-6

Parameter No	Setting value	Note
0	Always 0	Analog AO1 output has been 0
1	Always 10V / 20mA	Analog AO1 output has been 10V / 20mA
2	Output frequency	Analog AO1 output is output frequency
3	Motor current	Analog AO1 output is motor current
4	The output voltage	Analog AO1 output is output voltage
5	Motor torque	Analog AO1 output is motor torque
6	Output Power	Analog AO1 output is output power
7	Set frequency	Analog AO1 output is set frequency
100~9999	Parameter number	Select parameter as the source of analog AO1 signal

Parameter NO.	Parameter Name	Setting range	Unit	Factory value
P3.66	AO2 signal type	0: voltage output; 1: current output		0
P3.67	AO1 signal source	0: always 0; 1: Always 10V / 20mA; 2: Output frequency; 3: Motor current; 4: Output voltage; 5: Motor torque; 6: Output power; 7: Set frequency; 100 ~ 9999: quote the value of the parameter number		3
P3.68	AO2 low-end setting	-999999.000~999999.000	%	0.000
P3.69	AO2 high-end settings			50.000
P3.70	AO2 low-end voltage (current)		V(mA)	0.000
P3.71	AO2 high-end voltage (current)			10.000

- Function: Analog output AO2 setting

➤ For details, please refer to P3.60 ~ P3.65.

Group 04 parameters: PID control

Parameter NO.	Parameter Name	Setting range	Unit	Factory value
P4.00	PID proportional gain	0.000~10.000	%	0.010
P4.01	PID integration time	0.001~9999.000	S	10.000

P4.02	PID differential gain	0.000~9999.000	%	0.000
P4.03	PID forward feedback coefficient	0~500	%	0
P4.04	PID sampling time	0.001~9999.000	S	0.004
P4.05	PID output upper limit	-1000.000~1000.000	%	100.000
P4.06	PID output lower limit	-1000.000~1000.000	%	0.000
P4.07	PID output filter time	0.000~600.000	S	0.000
P4.09	PID range	0.001~99999.000		100.000

- Function: Simple PID control, enable PID control when P2.13 or P2.14 is set to 8

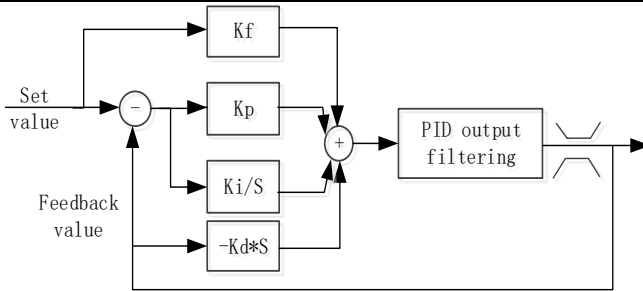

Figure 6-4-1 PID closed loop control

PID proportional gain: Determine the adjustment intensity of the entire PID regulator. The greater the proportional gain, the greater the adjustment intensity.

PID integration time: determine the speed of PID regulator to adjust the deviation of PID feedback and given amount. The smaller the integration time, the greater the adjustment intensity.

PID differential gain: determine the strength of PID regulator to adjust the deviation rate of PID feedback and given amount. The greater the differential gain, the greater the adjustment intensity.

PID feedforward coefficient: generally use a smaller feedforward coefficient; otherwise, use a larger feedforward coefficient to make feedforward adjustment play a major role.

PID sampling time: generally set 5 ~ 10 times smaller than the response time of the controlled object.

PID output upper limit: the maximum value of PID adjustment output, higher than the maximum value, PID output upper limit.

PID output lower limit: the minimum value of PID adjustment output, below the minimum value, PID output lower limit.

PID output filtering time: The filtering time increases, weakens the output signal mutation, and reduces the closed-loop system response performance.

PID range: according to the actual feedback range setting, if the setting is less than the feedback range PID does not work.

Method of adjusting proportional gain and integration time:

First adjust the integration time to the minimum, set the differential gain to 0, observe the PID feedback value and adjust the PID proportional gain. Slowly increase the integration time, repeatedly adjust the two parameters of proportional gain and integration time according to the response of the PID feedback value, change the PID given value multiple times within the PID given range, and adjust the proportional gain and integration time until Achieve satisfactory performance within the entire working range. Differential gain can be adjusted according to the need of overshoot, in most cases the differential link is generally not used.

Parameter NO.	Parameter Name	Setting range	Unit	Factory value
---------------	----------------	---------------	------	---------------

P4.11	PID sleep frequency	0.000~500.000	%	0.000
P4.12	PID enters sleep time	0.000~3600.000	S	0.000
P4.13	PID wake-up deviation	0.000~100.000	%	0.000
P4.14	PID entry wake-up time	0.000~3600.000	S	0.000
P4.15	PID sleep action	0: do not sleep; 1: PID stop; 2: Slow down; 3: Free to stop; 4: Pause; 5: Lowest frequency operation		0

- Function: PID control function selection

Principle explanation:

As shown in Figure 6-4-2, the PID output value is less than the P4.11 sleep frequency. After the time set by the parameter P4.12 (PID enters sleep time), the PID enters sleep according to the sleep action; the PID wakeup value is greater than P4.13 wakeup Deviation (wake-up value = percentage of set value), after the time set by parameter P4.14 (PID enters wake-up time), PID restarts.

•PID sleep frequency: set the sleep quasi-frequency.

•PID wake up deviation: percentage based on setting. For example, when 10 kg is set and the wake-up deviation is 20%, the wake-up deviation is 2 kg (20% × 10). When the actual pressure is less than 8 kg, the wake-up state starts.

•PID enters sleep time: the inverter will enter sleep after reaching the sleep frequency and meeting the sleep time.

•PID enters the wake-up time: the inverter will restart after reaching the wake-up deviation and meeting the wake-up time.

•PID sleep action selection: PID enters sleep according to the set sleep action.

0 Do not sleep: PID operation is not changed.

1 PID stop: PID stops working.

2 Deceleration stop: The inverter decelerates to stop.

3 Free stop: The inverter freely stops.

4 Pause: The inverter pauses.

5 Lowest frequency operation: run at the lowest frequency, see parameter P4.06 (PID output lower limit frequency) for lowest frequency setting.

Note: When the PID sleep action selects deceleration stop or free stop, sleep will cause the start signal to be cleared once. Therefore: when the start signal comes from the keyboard, the start signal will be cleared after sleep. If the automatic wake-up function is required, select PID to stop or pause or the lowest frequency operation for PID sleep action. When the start signal comes from the S terminal input or communication (the communication continues to send the start signal), the PID sleep action will not affect the PID wakeup.

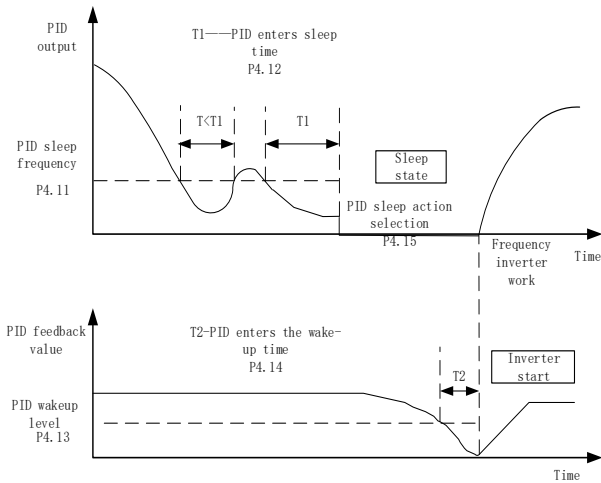

Figure 6-4-2 PID Wake up from sleep

Parameter NO.	Parameter Name	Setting range	Unit	Factory value
P4.90	PID status	0~4294967295		

- Function: indicates the PID status word (see the table below for the definition of each bit).

Table 6-4-1

Status word (Bit)	Definition
0	PID is stopped
1	PID is running
5	PID goes to sleep

Group 05 parameters: system control

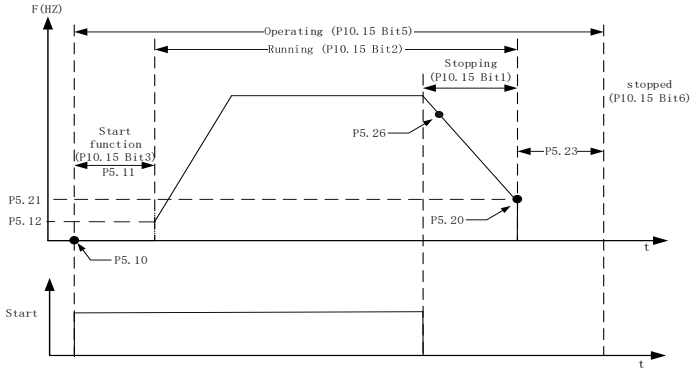

Figure 6-5-1 System control

Parameter NO.	Parameter Name	Setting range	Unit	Factory value
P5.00	Control mode	0: VF; 1: Open loop vector 1		1

- Function: Select motor control algorithm

Parameter NO.	Parameter Name	Setting range	Unit	Factory value
P5.06	Forward and reverse switching time	0.000~6000.000	S	0.000

- Function: control forward and reverse switching dead time

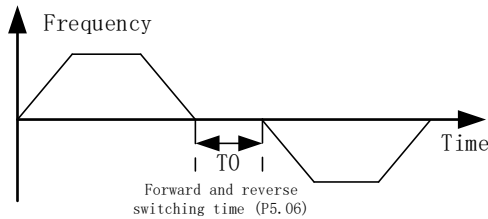

Figure 6-5-2 Switching between forward and reverse

Parameter NO.	Parameter Name	Setting range	Unit	Factory value
P5.07	Forced change direction	0: No effect; 1: forced change direction		0

- Function: control the commutation function, when the parameter P5.07 is set to 1, change the current running direction

Parameter NO.	Parameter Name	Setting range	Unit	Factory value
P5.08	Motor frequency upper limit	-1020.000~1020.000	Hz	55.000

- Function: Motor output frequency limit

> Motor frequency upper limit: define the motor operating frequency upper limit.

Parameter NO.	Parameter Name	Setting range	Unit	Factory value
P5.10	Start function	0: Start frequency operation; 1: On speed start; 2: DC injection		0
P5.11	Start Time	0.000~60000.000	S	0.000
P5.12	Start frequency	0.000~100.000	Hz	0.000

- Function: Set start function

Principle explanation:

When the system starts, it will work according to the set start function within the set start time. After the start function is over, if the set frequency is greater than the start frequency, the system starts to run at the start frequency; if the set frequency is less than the start frequency, the system starts to run at the set frequency.

□ Start function:

0: Start mode with no output frequency, meet the setting of P5.11 start time, P5.12 start frequency starts to start running.

1: Start flying, search the speed of the rotating motor, and start a smooth start without impact from the speed found.

2: DC injection, the inverter starts by "DC injection first".

Parameter NO.	Parameter Name	Setting range	Unit	Factory value
P5.14	On speed start mode	0: All directional; 1: Set value direction; 2~3: reserved		0

- Function: Set the speed start function (set P5.10 to 1 speed start)

□ Speed start mode:

0: Two-way, follow the forward or reverse direction for speed tracking judgment.

1: Set value direction, follow the set direction for speed tracking judgment.

Parameter NO.	Parameter Name	Setting range	Unit	Factory value
P5.19	DC injection current	0.000~200.000	%	100.000

- Function: Set the DC injection current size (set P5.10 to 2 DC injection)

□ Principle explanation:

When the starting method is DC injection, the DC braking current needs to be set to 100% corresponding to the rated current of the inverter.

Parameter NO.	Parameter Name	Setting range	Unit	Factory value
P5.20	Stop function	Units: 0: free parking; 1: DC braking; Ten: 1: precise parking		0
P5.21	Stop frequency	0.000~1000.000	Hz	0.000

- Function: Set stop function

□ Principle explanation:

During the stop process, when the output frequency is less than the stop frequency, the stop function starts to work.

Precise parking: The motor rotates the same number of revolutions at any speed to achieve consistent repeatability of the parking position. To achieve the best results, the deceleration time should be as long as possible so as not to trigger the overvoltage and overcurrent stall prevention functions.

Parameter NO.	Parameter Name	Setting range	Unit	Factory value
P5.22	DC braking current	0.000~150.000	%	100.000
P5.23	DC braking time	0.000~1000.000	S	0.000
P5.24	Demagnetization time ratio	0.000~1000.000	%	10.000

- Function: Set the DC braking parameters of the stop function

□ DC braking current: set the DC braking current.

□ DC braking time: set the DC braking time.

□ Demagnetization time ratio: Generally, no modification is required. For occasions requiring accurate positioning and strict deceleration time, reduce the demagnetization time ratio; where the requirements for deceleration time are not strict, appropriately increase the demagnetization time ratio to reduce the deceleration current impact.

Parameter NO.	Parameter Name	Setting range	Unit	Factory value
P5.26	Magnetic flux brake activation frequency	0.000~1000.000	Hz	0.000
P5.27	Magnetic Flux braking coefficient	100~200	%	100
P5.28	Magnetic Flux braking time	0.000~1000.000	S	0.000

- Function: Set the flux braking parameters of the stop function

□ Principle explanation:

During the stop, when the output frequency is less than the flux braking activation frequency, the flux braking function starts to take effect during the flux braking time. Flux braking is generally used in situations that require rapid deceleration, but excessive use will cause the motor to heat up.

Parameter NO.	Parameter Name	Setting range	Unit	Factory value
P5.30	Brake resistance mode	0: invalid; 1: Maximum duty cycle;		1

- Function: Braking resistor braking mode parameter setting

Parameter NO.	Parameter Name	Setting range	Unit	Factory value
P5.50	Auto reset mode	0~9999		0
P5.51	Auto reset time	0.000~600.000	S	10.000

- Function: Set automatic reset function

Principle explanation:

If the parameter P5.50 is not 0, the automatic reset function is valid, the number of automatic resets is the set value of P5.50, and the automatic reset time is the time when the fault is delayed. If P5.50 is set to 9999, it can be reset any number of times. If P5.50 is set greater than 0 and less than 9999, when the number of automatic resets exceeds P5.50, the inverter will report a fault.

Parameter NO.	Parameter Name	Setting range	Unit	Factory value
P5.60	Automatic energy saving minimum flux	30~100	%	100
P5.61	Automatic energy saving start frequency	0~200.000	Hz	5.000

- Function: Set automatic energy saving function

Principle explanation:

Automatic energy saving automatically adjusts the output voltage according to the motor load to achieve the purpose of energy saving. When P6.70 is set to 1, P5.60 set value is less than 100 and the running frequency is greater than P5.61, the automatic energy saving function is effective.

Parameter NO.	Parameter Name	Setting range	Unit	Factory value
P5.63	Manual energy-saving magnetic flux	30~90	%	70

- Function: Set manual energy-saving magnetic flux size

Principle explanation:

When P6.70 is set to 1 and the automatic energy saving function is invalid, manual energy saving is effective. If P5.63 is set to 100, manual energy saving is invalid. Adjust the energy saving effect by setting the parameter P5.63 magnetic flux size. The smaller the set value, the more obvious the energy saving effect, but the torque response speed becomes slower.

Parameter NO.	Parameter Name	Setting range	Unit	Factory value
---------------	----------------	---------------	------	---------------

P5.71	Current upper-limit	0~300	%	150
-------	---------------------	-------	---	-----

- Function: When the running current is greater than the upper current limit, the overcurrent stall function is activated. The current reference is the motor rated current (P6.14).

Parameter NO.	Parameter Name	Setting range	Unit	Factory value
P5.76	Upper limit of electric torque	0.000~900.000	%	150.000
P5.77	Upper limit of regenerative torque	0.000~900.000	%	150.000

- Function: Set torque limit function

Principle explanation:

Parameters P5.76 and P5.77 set the upper limit of electric and regenerative torque.

Parameter NO.	Parameter Name	Setting range	Unit	Factory value
P5.80	Over-voltage control	0: invalid; 1: valid at all times		1
P5.82	Over-voltage control scale factor	0~200	%	100
P5.83	Over-voltage control integral coefficient	0~10000	%	100

- Function: Set overvoltage control function

Principle explanation:

When the regenerative voltage exceeds the set threshold, the overvoltage control starts to activate the overvoltage stall function according to the setting of parameter P5.80.

Parameter NO.	Parameter Name	Setting range	Unit	Factory value
P5.85	Under-voltage control	Units: grid power-down action mode 0: invalid; 1: Instant stop; 2: Safe parking; 3 ~ 6: reserved Tens: Under-voltage operation mode of power grid 0: invalid; 1: Safe frequency reduction		0
P5.86	Power grid voltage level	100~800	V	*

- Function: Set undervoltage control function

Principle explanation:

When the input voltage is lower than the grid power-down level, the power-down action starts to activate according to the parameter P5.85 bit setting. Grid undervoltage means that the grid voltage is lower than the

F100 series vector control inverter manual V1.0

normal voltage, and the undervoltage action starts to activate according to the parameter P5.85 tens place setting.

Parameter NO.	Parameter Name	Setting range	Unit	Factory value
P5.90	AVR function selection	0: invalid; 1: valid; 2: Only invalid when decelerating		1
P5.91	AVR function damping factor	0~400	%	100

- Function: Set AVR function

Principle explanation:

AVR is used to compensate the fluctuation of grid voltage and keep the output voltage constant. When P5.90 is selected as 2, it is conducive to rapid deceleration.

Group 06 parameters: motor model

Parameter NO.	Parameter Name	Setting range	Unit	Factory value
P6.00	Motor parameter self-learning	0: invalid 1: Complete self-learning 2: Simple self-learning		0

- Function: Online learning of motor parameters

Principle explanation:

During complete self-learning and simple self-learning, the motor will not rotate. After self-learning, the parameters such as motor stator impedance and rotor impedance will change. Before motor parameter self-learning, input motor nameplate parameters P6.10 ~ P6.15.

Self-learning process: Set P6.00, press the run key to start self-learning. When the self-learning is normal, the keyboard displays L0. After the self-learning is completed, press the stop key to exit the self-learning and return to the normal state.

Parameter NO.	Parameter Name	Setting range	Unit	Factory value
P6.05	Carrier frequency	2~16	kHz	*

- Function: Set carrier frequency

Parameter NO.	Parameter Name	Setting range	Unit	Factory value
P6.06	Over-modulation function	0: invalid; 1: valid		1

- Function: Set over modulation function

Parameter NO.	Parameter Name	Setting range	Unit	Factory value
P6.10	Motor type	0: Asynchronous motor; 1: Surface mount permanent magnet synchronization; 2: Salient pole permanent magnet synchronization 4: single-phase motor		0
P6.11	Motor Power	0.000~100000.000	kW	*
P6.12	Motor voltage	0~1000	V	*
P6.13	Motor frequency	1~3000	Hz	*
P6.14	Motor current	0.00~1000.00	A	*
P6.15	Motor speed	10~65535	RPM	*
P6.16	Motor power factor	0.00~1.00		*
P6.17	Number of motor poles	2~100		*
P6.18	Motor rated torque	0.1~10000.0	NM	*
P6.19	Motor no-load current	0.00~1000.00	A	*

- Function: Set motor parameters

Parameter NO.	Parameter Name	Setting range	Unit	Factory value
P6.20	PM motor back EMF / rev	1.000~1000.000	mV/rpm	*

- Function: Set the back EMF corresponding to the rated speed of the permanent magnet synchronous motor

Parameter NO.	Parameter Name	Setting range	Unit	Factory value
P6.40	Stator impedance	0.000~999.990	Ω	*
P6.41	Rotor impedance	0.000~999.990	Ω	*
P6.42	Stator leakage reactance	0.000~9999.990	mH	*
P6.44	Motor main reactance	0.00~999.90	mH	*

- Function: Motor model parameters (obtained by self-learning of motor parameters)

Parameter NO.	Parameter Name	Setting range	Unit	Factory value
P6.50	PM d-axis reactance	0.000~1000.000	mH	*
P6.51	PM q-axis reactance	0.001~9999.000	mH	*
P6.52	PM d 轴电抗饱和系数	0.0~100.0	%	*
P6.53	PM q 轴电抗饱和系数	0.0~100.0	%	*

P6.54	PM d-axis reactance saturation coefficient	10~400	%	100
P6.55	PM q axis reactance saturation coefficient	10~400	%	100

- Function: Permanent magnet synchronous motor model parameters (obtained by self-learning of motor parameters)

Parameter NO.	Parameter Name	Setting range	Unit	Factory value
P6.60	Maximum field weakening current d	0.200 ~ 1.800		1.000

- Function: Set single-phase motor turn ratio

Parameter NO.	Parameter Name	Setting range	Unit	Factory value
P6.70	Load type	0: constant torque; 1: fan water pump; 2: promotion; 3: reserved		0

- Function: Select the appropriate load type to obtain the corresponding torque characteristics, optimize the control algorithm

Parameter NO.	Parameter Name	Setting range	Unit	Factory value
P6.80	Motor cable compensation strength	0: low; 1: medium; 2: high		0

- Function: generally select 0 for unshielded wire;
For shielded cables of about 15 meters, select 1;
For longer shielded cable, select 2.

Group 07 parameters: control algorithm

Parameter NO.	Parameter Name	Setting range	Unit	Factory value
P7.50	Slip compensation	-500~500	%	100
P7.51	Slip compensation filter constant	1~10000	%	100

- Function: Set vector control slip compensation parameters

➤ Slip compensation: adjust the speed stability accuracy of the motor. When the motor is under heavy load, the speed is low, increase this parameter, otherwise reduce this parameter. (For the need of soft load, provide negative value selection)

Parameter NO.	Parameter Name	Setting range	Unit	Factory value
P7.52	Resonance suppression coefficient	0~10000	%	100
P7.53	Low-speed suppression filter constant	1~10000	%	100
P7.54	High-speed suppression filter constant	1~10000	%	100

- Function: Set resonance suppression coefficient, high and low speed suppression filter constant

Principle explanation:

The no-load frequency conversion control system is prone to resonance, and the resonance suppression function helps eliminate vibration.

Parameter NO.	Parameter Name	Setting range	Unit	Factory value
P7.55	Automatic torque boost coefficient	0~300	%	100

- Function: Set automatic torque boost coefficient

Principle explanation:

According to the load, the output voltage at low frequency is automatically compensated to improve the load capacity at low frequency.

Parameter NO.	Parameter Name	Setting range	Unit	Factory value
P7.57	Low speed minimum current	0~300	%	50
P7.58	Static friction lift coefficient	0 ~10000	%	100
P7.59	Static friction lift time	0.0~1000.0	S	0.0

- Function: Set low speed minimum current and static friction parameters

ⓘ Principle explanation:

Low speed minimum current Given the minimum current at low speed, proper settings help to improve the low speed load capacity. The static friction lifting function automatically compensates the output voltage at the start according to the load, thereby increasing the starting torque.

Parameter NO.	Parameter Name	Setting range	Unit	Factory value
P7.71	VF curve-F1	0~3000	Hz	50
P7.72	VF curve-F2			50
P7.73	VF curve-F3			50
P7.74	VF curve-F4			50
P7.75	VF curve-V0	0~10000	V	0
P7.76	VF curve-V1			*
P7.77	VF curve-V2			*
P7.78	VF curve-V3			*
P7.79	VF curve-V4			*

- Function: Set VF curve

Principle explanation:

Set the V / F curve in V / F control mode. When vector control 1 is used, the corresponding data points of the V / F curve can be set to adjust the control characteristics of the corresponding control points.

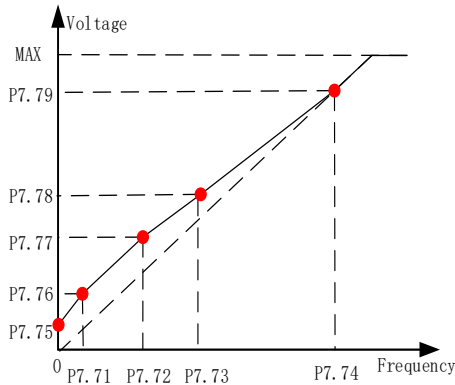

Figure 6-7-1 VF control curve

Group 09 parameters: system protection

Parameter NO.	Parameter Name	Setting range	Unit	Factory value
P9.00	Input phase loss action	0: failure; 1: alarm; 2: invalid;		2

- Function: Set input phase loss action

Parameter NO.	Parameter Name	Setting range	Unit	Factory value
P9.04	Output phase loss detection	0: invalid; 1: valid		1

- Function: Set the action when output phase loss protection

Parameter NO.	Parameter Name	Setting range	Unit	Factory value
P9.06	ETR selection	0: invalid; 1: alarm; 2: fault		2

- Function: Select ETR action

Group 10 parameters: system status

Parameter NO.	Parameter Name	Setting range	Unit	Factory value
P10.05	Software version number			

- Function: Indicate the inverter software version number.

Parameter NO.	Parameter Name	Setting range	Unit	Factory value
P10.10	Control word	0~4294967295		

- Function: indicates the system control word. The definition of each bit is shown in the table below:

Table 6-9-1

Control word (Bit)	Definition
0	start up
1	Reverse
2	Start reverse
3	JOG
4	stop
5	Emergency stop
6	Safe stop
7	Reset
9	Parameter self-learning
10	Jump
11	time out
13	UP (incremental)
14	DOWN (decreasing)

Parameter NO.	Parameter Name	Setting range	Unit	Factory value
P10.11	Set value	-65535.0~65535.0		

- Function: Indicate the set frequency value, see Figure 6-2-1

Parameter NO.	Parameter Name	Setting range	Unit	Factory value
P10.15	Current status	0~4294967295		

- Function: Indicates the system status word (see the table below for the definition of each bit). The specific meaning is shown in Figure 6-5-1.

Table 6-9-2

Control word (Bit)	Definition
0	Powering off
1	Stopping
2	running
3	Start function start
4	Parameter self-study
5	Operating
6	Ready
10	Fault
11	Error
12	STO status

Parameter NO.	Parameter Name	Setting range	Unit	Factory value
P10.16	Fault status word 1	0~4294967295		
P10.17	Fault status word 2	0~4294967295		

- Function: indicate the system fault status word (see the table below for the definition of each bit)

Fault status word 1 (Bit)	Definition
1	System abnormality
4	Ground fault
5	Short circuit to ground
6	Output short circuit
7	Output overcurrent
8	DC bus overvoltage
9	DC bus undervoltage
10	Inverter overheating
11	Self-learning failure
13	Rectifier bridge overheating
14	U phase missing phase
15	V Phase missing phase
16	W phase missing phase
19	No motor connection
20	Input phase loss
21	Inverter overload
22	Overtorque
24	Motor overheating
25	Motor overload
26	Current limit
27	Input power down
Fault status word 2 (Bit)	Definition
31	External fault

Parameter NO.	Parameter Name	Setting range	Unit	Factory value
P10.18	Alarm status word	0~4294967295		

- Function: indicate the system alarm status word (see the description of the above table for the definition of each Bit)

Parameter NO.	Parameter Name	Setting range	Unit	Factory value
P10.20	Output frequency absolute value	0.0~65535.0	Hz	
P10.21	Output frequency	-65535.0~65535.0	Hz	
P10.22	Output current	0.00~65535.00	A	
P10.23	Output voltage	0.0~65535.0	V	
P10.24	Output torque	0.000~65535.000	N.M	

- Function: Indicate output information

Parameter NO.	Parameter Name	Setting range	Unit	Factory value
P10.25	DC voltage	0.0~65535.0	V	
P10.26	Inverter temperature	0~65535	°C	
P10.27	Inverter hot load	0~65535	%	
P10.28	Motor hot load	0~65535	%	
P10.30	power	0.000~65535.000	kw	
P10.31	Energy consumption	0.000~4294967.295	Kw* h	

- Function: Indicate the running status information of the inverter

Parameter NO.	Parameter Name	Setting range	Unit	Factory value
P10.40	Hours of power on	0.000~4294967.295	h	
P10.41	Number of power-on	0~4294967295		

- Function: Instruct inverter statistics

Parameter NO.	Parameter Name	Setting range	Unit	Factory value
P10.60	Current alarm number	0~4294967295		
P10.61	Current fault number			
P10.62	Last fault number			
P10.63	The first two fault numbers			

- Function: Indicate the inverter fault information, (refer to chapter 10.2 Troubleshooting)

Parameter NO.	Parameter Name	Setting range	Unit	Factory value
P10.70	S input terminal status	0~4294967295		
P10.71	AI1 terminal input value	-65535.000~65535.000	%	
P10.72	AI2 terminal input value	-65535.000~65535.000	%	
P10.74	Y terminal output status	0~4294967295		

P10.75	AO1 terminal output value	-65535.000~65535.000	%	
P10.76	AO2 terminal output value	-65535.000~65535.000	%	

- Function: indicate external terminal information

Parameter NO.	Parameter Name	Setting range	Unit	Factory value
P10.78	Pulse input frequency	0.000~10000.000	k Hz	
P10.79	Pulse output frequency	0.000~10000.000	kHz	

- Function: Indicate pulse input and output frequency

Parameter NO.	Parameter Name	Setting range	Unit	Factory value
P10.80	Encoder count	0~4294967295		
P10.81	Encoder speed	-9999.000~9999.000	Hz	
P10.82	Encoder angle	0.0~359.9	Deg	

- Function: indicate encoder status

Parameter NO.	Parameter Name	Setting range	Unit	Factory value
P10.90	Set value 1	-999999.000~999999.000	%	
P10.91	Set value 2	-999999.000~999999.000	%	
P10.92	Set value 3	-999999.000~999999.000	%	

- Function: Indicate the set value, see Figure 6-2-1

Parameter NO.	Parameter Name	Setting range	Unit	Factory value
P10.98	Display value 1	-99999.000~99999.000		
P10.99	Display value 2	-99999.000~99999.000		

- Function: indicate the display value (see P1.68 ~ P1.69 for the source of the display value)

Group 11 parameters: fault record

Parameter NO.	Parameter Name	Setting range	Unit	Factory value
P11.10	Present fault output frequency	-999999.0~999999.0	Hz	0.0
P11.11	Present fault output current	-999999.00~999999.00	A	0.00
P11.12	Present fault bus voltage	-999999.0~999999.0	V	0.0
P11.13	Present faulty inverter temperature	-999999~999999	°C	0
P11.14	Present fault X terminal status	-999999~999999		0
P11.15	Present fault Y terminal status	-999999~999999		0
P11.16	Accumulated power-on time	0.000~4294967.295	h	0
P11.20	Output frequency of previous fault	-999999.0~999999.0	Hz	0.0
P11.21	output current of Previous fault	-999999.00~999999.00	A	0.00
P11.22	Bus voltage of previous fault	-999999.0~999999.0	V	0.0
P11.23	Inverter temperature of previous fault	-999999~999999	°C	0
P11.24	S-terminal status of previous fault	-999999~999999		0
P11.25	Y terminal status of previous fault	-999999~999999		0
P11.26	Accumulated power-on time of the previous fault	0.000~4294967.295	h	0
P11.30	Output frequency of the 2rd faults	-999999.0~999999.0	Hz	0.0
P11.31	The 2rd fault output currents	-999999.00~999999.00	A	0.00
P11.32	Bus voltage of 2rd faults	-999999.0~999999.0	V	0.0
P11.33	Inverter temperature of the 2rd faults	-999999~999999	°C	0
P11.34	S-terminal status of the 2rd faults	-999999~999999		0
P11.35	The 2rd fault Y terminal status	-999999~999999		0
P11.36	Accumulated power-on time of the 2rd fault	0.000~4294967.295	h	0

- Function: record fault information

Group 12 parameters: free parameters

Parameter NO.	Parameter Name	Setting range	Unit	Factory value
P12.00 ~ P12.19	Free parameter 1 ~ Free parameters 20	-999999.000~999999.000		0.000
P12.90 ~ P12.99	Free parameter 91 ~ Free parameters 100	-999999.000~999999.000		0.000

- Function: As an interface or intermediate quantity, expand system functions

Principle explanation:

P12.00 ~ P12.19, P12.90 ~ P12.94, automatically save the current value when power off.
 P12.95 ~ P12.99: Set the parameter number. The value of P12.90 ~ P12.94 at power-on is given to the parameter number set in P12.95 ~ P12.99.
 Only P12.90 ~ P12.99 parameters are automatically saved after power off.

Group 13 parameters: function output

Parameter NO.	Parameter Name	Setting range	Unit	Factory value
P13.00	Comparator output	0~4294967295		0
P13.01	Logic output			

- Function: Indicate comparator output (see P16.00 ~ P16.35), logic output result (see P16.36 ~ P16.75)

- Comparator output: store all comparator results, bit0 stores comparator 1 results, bit1 stores comparator 2 results, ...
- Logic output: store all logical unit results, bit0 stores logical unit 1 results, bit1 stores logical unit 2 results, ...

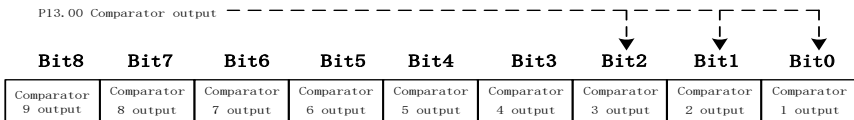

Figure 6-12-1 indicates the output of the comparator

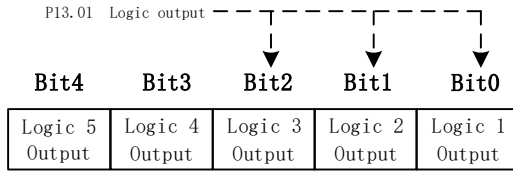

Figure 6-12-2 Indicate the logic output result

Parameter NO.	Parameter Name	Setting range	Unit	Factory value
P13.02	Linear transformation 1 result	-999999.000~999999.000		0.000
P13.03	Linear transformation 2 result	-999999.000~999999.000		0.000

- Function: Indicate the result of linear transformation (see P17.00 ~ P17.09)

Parameter NO.	Parameter Name	Setting range	Unit	Factory value
P13.10	Single arithmetic operation 1 output	-999999.000~999999.000		0.000
P13.11	Single arithmetic operation 2 output	-999999.000~999999.000		0.000
P13.12	Single arithmetic operation 3 output	-999999.000~999999.000		0.000
P13.13	Single arithmetic operation 4 output	-999999.000~999999.000		0.000
P13.14	Single arithmetic operation 5 output	-999999.000~999999.000		0.000

- Function: Indicate the output result of single arithmetic operation (P17.16 ~ P17.25)

Parameter NO.	Parameter Name	Setting range	Unit	Factory value
P13.15	Math operation 1 output	-999999.000~999999.000		0.000
P13.16	Math operation 2 output	-999999.000~999999.000		0.000
P13.17	Math operation 3 output	-999999.000~999999.000		0.000
P13.18	Math operation 4 output	-999999.000~999999.000		0.000

- Function: Indicate the output result of mathematical operation (see P17.26 ~ P17.45)

Parameter NO.	Parameter Name	Setting range	Unit	Factory value
P13.40	Comparator 1 output	0~1		0
P13.41	Comparator 2 output	0~1		0
P13.42	Comparator 3 output	0~1		0
P13.43	Comparator 4 output	0~1		0
P13.44	Comparator 5 output	0~1		0
P13.45	Comparator 6 output	0~1		0
P13.46	Comparator 7 output	0~1		0
P13.47	Comparator 8 output	0~1		0
P13.48	Comparator 9 output	0~1		0

- Function: indicate the bit corresponding to the output of a single comparator (see P16.00 ~ P16.35)

Parameter NO.	Parameter Name	Setting range	Unit	Factory value
P13.50	Logic 1 output	0~1		0
P13.51	Logic 2 output	0~1		0
P13.52	Logic 3 output	0~1		0
P13.53	Logic 4 output	0~1		0
P13.54	Logic 5 output	0~1		0

- Function: Indicate the bit corresponding to the output of a single logic unit (see P16.36 ~ P16.75)

Parameter NO.	Parameter Name	Setting range	Unit	Factory value
P13.60	currently counting of Timer 1	0~4294967295		0
P13.61	Timer 1 current value	0~65535		0
P13.62	Timer 1 current stage	0~16		0
P13.63	Timer 2 is currently counting	0~4294967295		0
P13.64	Timer 2 current value	0~65535		0
P13.65	Timer 2 current stage	0~16		0

- Function: indicate the timer result (see P18.00 ~ P18.39)

- Current timer value: The timer counts, the count value can be suspended or cleared.
- Current state of timer: indicates the state of the timer stage, bit0 corresponds to stage 1, bit1 corresponds to stage 2, ...
- Timer current stage: indicates the current stage of the timer.

Group 14 parameters: encoder

Parameter NO.	Parameter Name	Setting range	Unit	Factory value
P14.01	Encoder 1 resolution	1~2 ³¹		1024
P14.02	Encoder 1 direction	0: forward; 1: reversed		0

- Function: Set encoder parameters

Group 16 parameters: logic unit

Parameter NO.	Parameter Name	Setting range	Unit	Factory value
P16.00	Comparator 1 input parameter selection	0~65535		0
P16.01	Comparator 1 comparison parameter selection	0~65535		0
P16.02	Comparator 1 configuration	0:>; 1:<; 2:≥; 3:≤; 4:=; 5:≈; 6:≠		0
P16.03	Comparator 2 delay time	0.000~600.000		0.000
P16.04	Comparator 2 input parameter selection	0~65535		0
P16.05	Comparator 2 comparison parameter selection	0~65535		0
P16.06	Comparator 2 configuration	0:>; 1:<; 2:≥; 3:≤; 4:=; 5:≈; 6:≠		0
P16.07	Comparator 2 delay time	0.000~600.000		0.000
P16.08	Comparator 3 input parameter selection	0~65535		0
P16.09	Comparator 3 comparison parameter selection	0~65535		0

P16.10	Comparator 3 configuration	0:>; 1:<; 2:≥; 3:≤; 4:=; 5:≠; 6:≠		0
P16.11	Comparator 3 delay time	0.000~600.000		0.000
P16.12	Comparator 4 input parameter selection	0~65535		0
P16.13	Comparator 4 comparison parameter selection	0~65535		0
P16.14	Comparator 4 configuration	0:>; 1:<; 2:≥; 3:≤; 4:=; 5:≠; 6:≠		0
P16.15	Comparator 4 delay time	0.000~600.000		0.000
P16.16	Comparator 5 input parameter selection	0~65535		0
P16.17	Comparator 5 configuration	0~65535		0
P16.18	Comparator 5 delay time	0:>; 1:<; 2:≥; 3:≤; 4:=; 5:≠; 6:≠		0
P16.19	Comparator 6 input parameter selection	0.000~600.000		0.000
P16.20	Comparator 6 comparison parameter selection	0~65535		0
P16.21	Comparator 6 configuration	0~65535		0
P16.22	Comparator 6 delay time	0:>; 1:<; 2:≥; 3:≤; 4:=; 5:≠; 6:≠		0
P16.23	Comparator 7 input parameter selection	0.000~600.000		0.000
P16.24	Comparator 7 comparison parameter selection	0~65535		0

P16.25	Comparator 5 configuration	0-65535		0
P16.26	Comparator 7 configuration	0:>; 1:<; 2:≥; 3:≤; 4:=; 5:≠; 6:≠		0
P16.27	Comparator 7 delay time	0.000-600.000		0.000
P16.28	Comparator 8 input parameter selection	0-65535		0
P16.29	Comparator 8 comparison parameter selection	0-65535		0
P16.30	Comparator 8 configuration	0:>; 1:<; 2:≥; 3:≤; 4:=; 5:≠; 6:≠		0
P16.31	Comparator 8 delay time	0.000-600.000		0.000
P16.32	Comparator 9 input parameter selection	0-65535		0
P16.33	Comparator 9 comparison parameter selection	0-65535		0
P16.34	Comparator 9 configuration	0:>; 1:<; 2:≥; 3:≤; 4:=; 5:≠; 6:≠		0
P16.35	Comparator 9 delay time	0.000-600.000		0.000

- Function: Set comparison operation

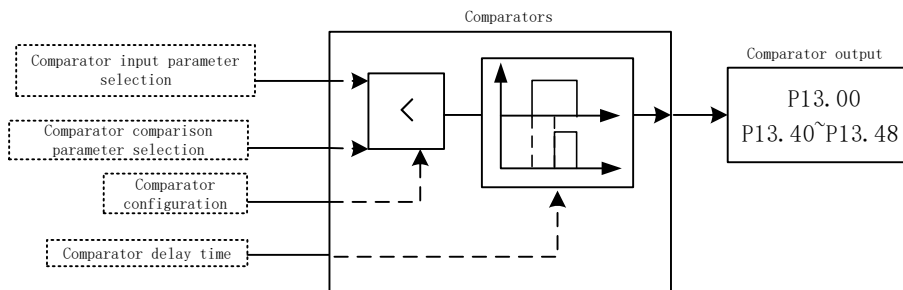

Figure 6-14-1 Comparators

- Comparator input parameter selection: this setting is the address. The address is the selected parameter number, and the actual value is determined by the current value of the selected parameter number.
- Comparator comparison parameter selection: this setting is the address. The address is the selected parameter number, and the actual value is determined by the current value of the selected parameter number.
- Comparator configuration: select the comparison relationship.
- Comparator delay time: After the delay time is reached, the comparator result is output.

Parameter NO.	Parameter Name	Setting range	Unit	Factory value
P16.36	Logic unit 1 parameter selection 1	0~65535		0
P16.37	Logic unit 1 input bit selection 1	0~32		0
P16.38	Logic unit 1 parameter selection 2	0~65535		0
P16.39	Logic unit 1 input bit selection 2	0~32		0
P16.40	Logic unit 1 parameter selection 3	0~65535		0
P16.41	Logic unit 1 input bit selection 3	0~32		0
P16.42	Logical unit 1 configuration 1	0: No effect; 1: with; 2: OR; 3: NAND; 4: NOR; 5: XOR		0
P16.43	Logical unit 1 configuration 2	0: No effect; 1: with; 2: OR; 3: NAND; 4: NOR; 5: XOR		0

P16.44	Logic unit 2 parameter selection 1	0~65535		0
P16.45	Logic unit 2 input bit selection 1	0~32		0
P16.46	Logic unit 2 parameter selection 2	0~65535		0
P16.47	Logic unit 2 input bit selection 2	0~32		0
P16.48	Logic unit 2 parameter selection 3	0~65535		0
P16.49	Logic unit 2 input bit selection 3	0~32		0
P16.50	Logical unit 2 configuration 1	0: No effect; 1: with; 2: OR; 3: NAND; 4: NOR; 5: XOR		0
P16.51	Logical unit 2 configuration 2	0: No effect; 1: with; 2: OR; 3: NAND; 4: NOR; 5: XOR		0

- Function: Set logic function

- Logic unit parameter selection: this setting is the address. The address is the selected parameter number, and the actual value is determined by the current value of the selected parameter number.
- □ Logic unit input bit selection: select the bit selection of logic operation parameters, 0 means bit0, 1 means bit1 ...
- □ Logic unit configuration 1: configure logical operation of logic unit parameters.

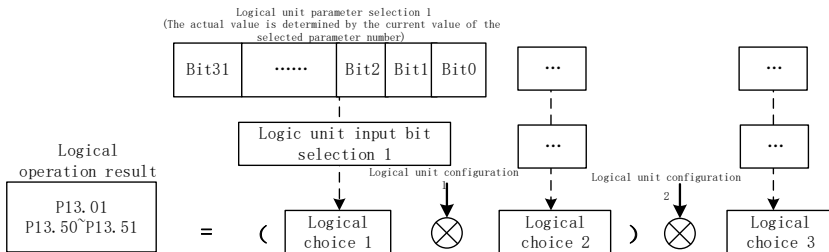

Figure 6-14-2 logic operation

Parameter NO.	Parameter Name	Setting range	Unit	Factory value
---------------	----------------	---------------	------	---------------

P16.76	Selector 1 parameter source	0~65535		0
P16.77	Selector 1 setting	0~16		0
P16.78	Selector 1 destination parameters	0~65535		0
P16.79	Selector 2 parameter source	0~65535		0
P16.80	Selector 2 setting	0~16		0
P16.81	Selector 2 destination parameters	0~65535		0
P16.82	Selector 3 parameter source	0~65535		0
P16.83	Selector 3 setting	0~16		0
P16.84	Selector 3 destination parameters	0~65535		0
P16.85	Selector 4 parameter source	0~65535		0
P16.86	Selector 4 setting	0~16		0
P16.87	Selector 4 destination parameters	0~65535		0
P16.88	Selector 5 parameter source	0~65535		0
P16.89	Selector 5 setting	0~16		0
P16.90	Selector 5 destination parameters	0~65535		0
P16.91	Selector 6 parameter source	0~65535		0
P16.92	Selector 6 setting	0~16		0
P16.93	Selector 6 destination parameters	0~65535		0
P16.94	Selector 7 parameter source	0~65535		0
P16.95	Selector 7 setting	0~16		0
P16.96	Selector 7 destination parameters	0~65535		0
P16.97	Selector 8 parameter source	0~65535		0
P16.98	Selector 8 setting	0~16		0
P16.99	Selector 8 destination parameters	0~65535		0

- Function: selector setting

†Principle explanation:

As shown in Figure 6-15-3, select one of the 16 consecutive addresses starting with the source of the

selector parameter, and pass the current value of this address to the destination parameter of the selector.

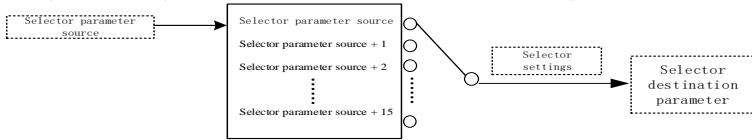

Figure 6-14-3 Selector

For example: P16.76 = 250, P16.78 = 270

When P16.77 = 0, the data of parameter P2.50 is transferred to P2.70;

When P16.77 = 1, the data of parameter P2.51 is transferred to P2.70;

When P16.77 = 2, the data of parameter P2.52 is passed to P2.70;

...

When P16.77 = 13, the data of parameter P2.63 is transferred to P2.70;

When P16.77 = 14, the data of parameter P2.64 is passed to P2.70;

When P16.77 = 15, the data of parameter P2.65 is transferred to P2.70.

Group 17 parameters: mathematical operations

Parameter NO.	Parameter Name	Setting range	Unit	Factory value
P17.00	Linear transformation parameter source 1	0~65535		0
P17.01	Linear transformation 1 X1	-999999.000~999999.000		0.000
P17.02	Linear transformation 1 X2	-999999.000~999999.000		50.000
P17.03	Linear transformation 1 Y1	-999999.000~999999.000		0.000
P17.04	Linear transformation 1 Y2	-999999.000~999999.000		1500.000
P17.05	Linear transformation parameter source 2	0~65535		0
P17.06	Linear transformation 2 X1	-999999.000~999999.000		0.000
P17.07	Linear transformation 2 X2	-999999.000~999999.000		0.000
P17.08	Linear transformation 2 Y1	-999999.000~999999.000		0.000
P17.09	Linear transformation 2 Y2	-999999.000~999999.000		0.000

- Function: Set linear transformation operation

Principle explanation:

As shown in Figure 6-15-1, the source parameter of the linear transformation parameter is set, and the current value of the reference parameter is used as the x input. Linear relationship setting (modify parameters P17.01-17.04 or parameters P17.05-P17.09).

[Example: Different output frequencies correspond to different speeds (0 ~ 50Hz corresponds to 0 ~

1500rpm), the setting parameters are as follows:

- P17.00 = 1021 (source of linear transformation 1 parameter is output frequency)
- P17.01 = 0 (linear transformation 1 X1 is 0)
- P17.02 = 50 (linear transformation 1 X2 is 50)
- P17.03 = 0 (linear transformation 1 Y1 is 0)
- P17.04 = 1500 (linear transformation 1 Y2 is 1500)
- P13.02 = Linear transformation 1 result

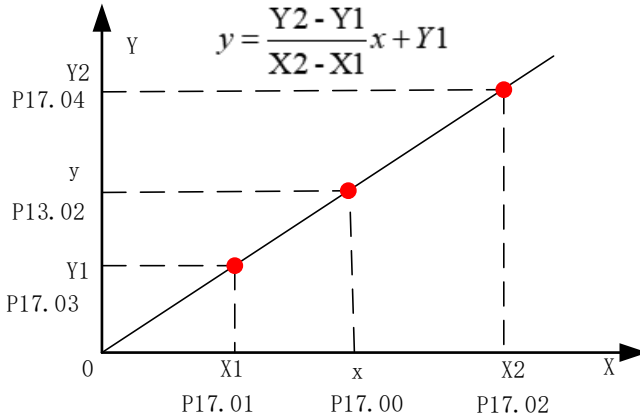

Figure 6-15-1 Linear transformation

Parameter NO.	Parameter Name	Setting range	Unit	Factory value
P17.16	Single arithmetic operation parameter source 1	0~65535		0
P17.17	Single arithmetic operation setting 1	0:ABS; 1:Sqrt; 2:Sin; 3:Cos; 4:power2; 5:Power3 6: random number		0
P17.18	Single arithmetic operation parameter source 2	0~65535		0
P17.19	Single arithmetic operation setting 2	0:ABS; 1:Sqrt; 2:Sin; 3:Cos; 4:power2; 5:Power3 6: random number		0

P17.20	Single arithmetic operation parameter source 3	0~65535		0
P17.21	Single arithmetic operation operation setting 3	0:ABS; 1:Sqrt; 2:Sin; 3:Cos; 4:power2; 5:Power3 6: random number		0
P17.22	Single arithmetic operation parameter source 4	0~65535		0
P17.23	Single arithmetic operation operation setting 4	0:ABS; 1:Sqrt; 2:Sin; 3:Cos; 4:power2; 5:Power3 6: random number		0
P17.24	Single arithmetic operation parameter source 5	0~65535		0
P17.25	Single arithmetic operation operation setting 5	0:ABS; 1:Sqrt; 2:Sin; 3:Cos; 4:power2; 5:Power3 6: random number		0

- Function: Set single arithmetic operation
- For example: P17.16 = 1200, P17.17 = 4, when P12.00 = 9.000, P13.10 = 81.000

Parameter NO.	Parameter Name	Setting range	Unit	Factory value
P17.26	Mathematical operation Parameter source 1	0~65535		0
P17.27	Mathematical operation Parameter source 2	0~65535		0
P17.28	Mathematical operation Parameter source 3	0~65535		0

P17.29	Math operation 1 Operation setting 1	0:No effect; 1:+; 2:-; 3:*; 4:/; 5:MAX; 6:Min; 7:Mean		0
P17.30	Math operation 1 Operation setting 2	0:No effect; 1:+; 2:-; 3:*; 4:/; 5:MAX; 6:Min; 7:Mean		0
P17.31	Mathematical operation Parameter source 1	2 0~65535		0
P17.32	Mathematical operation Parameter source 2	2 0~65535		0
P17.33	Mathematical operation Parameter source 3	2 0~65535		0
P17.34	Math operation 2 Operation setting 1	0:No effect 1:+; 2:-; 3:*; 4:/; 5:MAX; 6:Min; 7:Mean		0
P17.35	Math operation 2 Operation setting 2	0:No effect; 1:+; 2:-; 3:*; 4:/; 5:MAX; 6:Min; 7:Mean		0
P17.36	Mathematical operation Parameter source 1	3 0~65535		0

P17.37	Mathematical operation Parameter source 2	3 0~65535		0
P17.38	Mathematical operation Parameter source 3	3 0~65535		0
P17.39	Math operation 3 Operation setting 1	3 1:No effect; 2:+; 3:-; 4:*/; 5:MAX; 6:Min; 7:Mean		0
P17.40	Math operation 3 Operation setting 2	3 0:No effect; 1:+; 2:-; 3:*/; 4:*/; 5:MAX; 6:Min; 7:Mean		0
P17.41	Mathematical operation Parameter source 1	4 0~65535		0
P17.42	Mathematical operation Parameter source 2	4 0~65535		0
P17.43	Mathematical operation Parameter source 3	4 0~65535		0
P17.44	Math operation 4 Operation setting 1	4 0:No effect; 1:+; 2:-; 3:*/; 4:*/; 5:MAX; 6:Min; 7:Mean		0

P17.45	Math operation 4 Operation setting 2	0:No effect; 1:+; 2:-; 3:*; 4:/; 5:MAX; 6:Min; 7:Mean	0
--------	---	--	---

- Function: Set up math operation

- Source of mathematical operation parameters: this setting is the address. The address is the selected parameter number, and the actual value is determined by the current value of the selected parameter number.
- Math operation setting: set math operation.

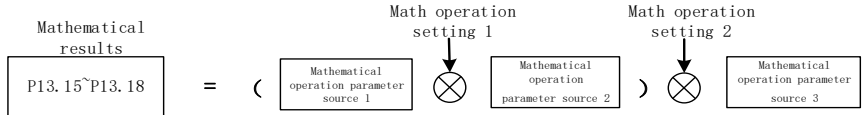

Figure 6-15-2 computation

For example: P17.26 = 1201, P17.27 = 1202, P17.28 = 1203, P17.29 = 1, P17.30 = 3
 When P12.01 = 2.000, P12.02 = 3.000, P12.03 = 5.000, the calculation result P13.15 = (2.000 + 3.000) * 5.000 = 25.000

Group 18 parameters: timing control

Parameter NO.	Parameter Name	Setting range	Unit	Factory value
P18.00	Timer 1 clock source	0:1mS; 1:10mS; 2:100mS; 3:1S; 200~3799:Address		0
P18.01	Timer 1 working mode	0: stop at the end of a single run; 1 ~ 16: Set the start of the next cycle		0
P18.02	Timer 1 control commands	Bit0: enable; Bit1: Start counting; Bit2: pause counting; Bit3: Clear count		0
P18.03	Timer 1 set value	-1~4294967295		-1
P18.04	Timer 1 phase 1 time	0~4294967295		0

P18.0 5	Timer 1 phase 2 time	0~4294967295		0
P18.0 6	Timer 1 phase 3 time	0~4294967295		0
P18.0 7	Timer 1 phase 4 time	0~4294967295		0
P18.0 8	Timer 1 phase 5 time	0~4294967295		0
P18.0 9	Timer 1 phase 6 time	0~4294967295		0
P18.1 0	Timer 1 phase 7 time	0~4294967295		0
P18.1 1	Timer 1 phase 8 time	0~4294967295		0
P18.1 2	Timer 1 phase 9 time	0~4294967295		0
P18.1 3	Timer 1 phase 10 time	0~4294967295		0
P18.1 4	Timer 1 phase 11 time	0~4294967295		0
P18.1 5	Timer 1 phase 12 time	0~4294967295		0
P18.1 6	Timer 1 phase 13 time	0~4294967295		0
P18.1 7	Timer 1 phase 14 time	0~4294967295		0
P18.1 8	Timer 1 phase 15 time	0~4294967295		0
P18.1 9	Timer 1 phase 16 time	0~4294967295		0
P18.2 0	Timer 1 clock source	0:1mS; 1:10mS; 2:100mS; 3:1S; 200~3799:Address		0
P18.2 1	Timer 1 working mode	0: stop at the end of a single run; 1 ~ 16: Set the start of the next cycle		0
P18.2 2	Timer 1 control commands	Bit0: enable; Bit1: Start counting; Bit2: pause counting; Bit3: Clear count		0
P18.2 3	Timer 1 set value	-1~4294967295		-1
P18.2 4	Timer 1 phase 1 time	0~4294967295		0

P18.2 5	Timer 1 phase 2 time	0~4294967295		0
P18.2 6	Timer 1 phase 3 time	0~4294967295		0
P18.2 7	Timer 1 phase 4 time	0~4294967295		0
P18.2 8	Timer 1 phase 5 time	0~4294967295		0
P18.2 9	Timer 1 phase 6 time	0~4294967295		0
P18.3 0	Timer 1 phase 7 time	0~4294967295		0
P18.3 1	Timer 1 phase 8 time	0~4294967295		0
P18.3 2	Timer 1 phase 9 time	0~4294967295		0
P18.3 3	Timer 1 phase 10 time	0~4294967295		0
P18.3 4	Timer 1 phase 11 time	0~4294967295		0
P18.3 5	Timer 1 phase 12 time	0~4294967295		0
P18.3 6	Timer 1 phase 13 time	0~4294967295		0
P18.3 7	Timer 1 phase 14 time	0~4294967295		0
P18.3 8	Timer 1 phase 15 time	0~4294967295		0
P18.3 9	Timer 1 phase 16 time	0~4294967295		0

- Function: Set timer parameters

□ Timer clock source: Set the timer clock source. Set to 0 ~ 199, this setting is to select a specific time interval, set to 200 ~ 3799, this setting is the address. The address is the selected parameter number, and the actual value is determined by the current value of the selected parameter number.

□ Timer working mode: set to 0, it will not cycle after the end of a single run; set to N (1 ≤ N ≤ 6), after the end of a single run, it will automatically start to cycle from N until the timer Stop when you can.

□ Timer control commands: □Bit0: enable; Bit1: start counting, rising edge signal enable; Bit2: pause counting; Bit3: clear counting.

□ Timer setting value: Set the timer count value.

□ Timer phase time: set the timer duration of each phase of the timer.

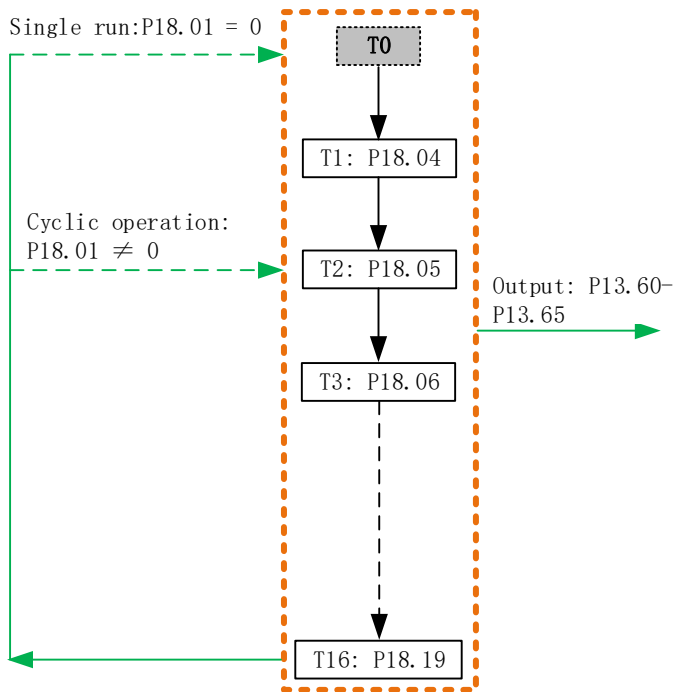

Figure 6-16-1 Timing control

Chapter 7 Application macro examples

7.1 Multi-speed control operation

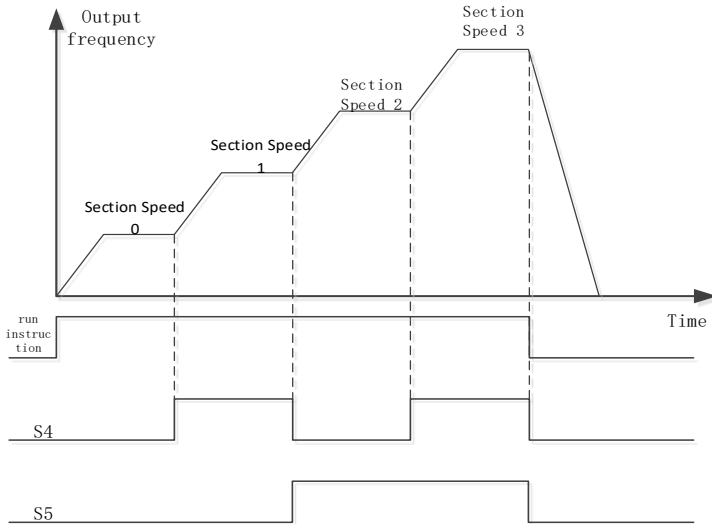

Figure 7-1 Multi-speed selection

Example: The external terminals S4 and S5 control the four-stage speed switching, and the multi-stage speeds are set to 10HZ, 15HZ, 20HZ, 25HZ respectively.

Step 1: Set P1.20 to 31, select multi-stage speed macro;

Step 2: Set P3.00 to 3, select external terminal S1 to control start.

➤ 6.11 Eight-speed internal control

Example: timing control of eight-stage speed switching, setting multi-stage speeds as 5HZ, 10HZ, 15HZ, 20HZ, 25HZ, 30HZ, 35HZ, 40HZ; external terminal S4 controls multi-stage speed enable, S1 controls motor start.

Step 1: Set P1.20 to 67, select the internal control eight-stage speed macro;

Step 2: Set P3.00 to 3, select external terminal S1 to control start.

Example: Timing control of eight-stage speed switching, setting multi-stage speeds as 5HZ, 10HZ, 15HZ, 20HZ, 25HZ, 30HZ, 35HZ, 40HZ; external terminal S4 controls multi-stage speed enable and motor start.

Step 1: Set P1.20 to 67, select the internal control eight-stage speed macro;

Step 2: Set P3.00 to 6, select external terminal S4 to control start.

6.11 PID control operation

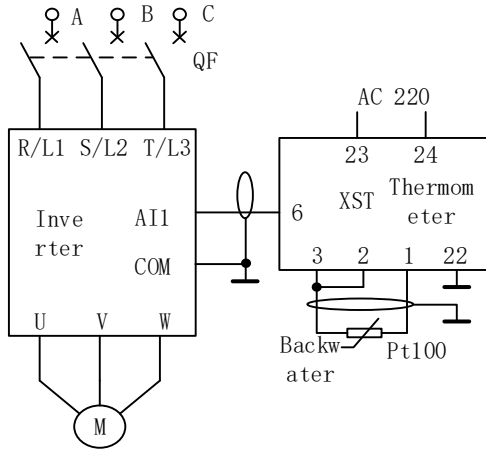

Figure 7-2 PID wiring

Example: PID control operation, set value is multi-step speed, feedback uses AI1, external terminal S1 controls start and stop.

Step 1: Set P1.20 to 32, select PID macro 1;

Step 2: Set P1.39 to 0, the command source setting select single command source mode;

Step 3: Set P3.00 to 3 and select S1 as the source of the start command.

Example: PID control operation, set value is AI2, feedback uses AI1, external terminal S1 controls start and stop.

Step 1: Set P1.20 to 33, select PID Macro 2;

Step 2: Set P1.39 to 0, the command source setting select single command source mode;

Step 3: Set P3.00 to 3 and select S1 as the source of the start command.

Figure 7-3 Application Macro

No.	Name	S1	S2	S3	S4	S5	Y1	Y2	Y3	AI1	AI2	AO1	AO2	Key board	Communication
0-9	User Macro 1 ~ 10	x	x	x	x	x	x	x	x	x	x	x	x	x	x
10	Comprehensive Macro 1	start up	Reverse start	JOG	Segment speed selection	Segment speed selection	running	Fault	alarm	Set value	x	Output frequency	Output current	Start and stop	Start / stop / setting value
11	Comprehensive Macro 2	start up	Forward and reverse	JOG	Segment speed selection	Segment speed selection	running	Fault	alarm	Set value	x	Output frequency	Output current	Start and stop	Start / stop / setting value

12	Comprehensive Macro 3	start up	stop	Forward and reverse	Segment speed selection	Segment speed selection	running	Fault	alarm	Set value	x	Output frequency	Output current	Start and stop	Start / stop / setting value
13	Comprehensive Macro 4	start up	stop	JOG	x	x	running	Fault	alarm	Feedback value	Set value	Output frequency	Output current	Start and stop	Start and stop
20	1-line command macro	start up	x	x	x	x	x	x	x	x	x	x	x	Start and stop	Start / stop / free stop
21	2-line command macro 1	start up	Reverse start	x	x	x	x	x	x	x	x	x	x	Start and stop	Start / stop / free stop
22	2-line command macro 2	start up	Forward and reverse	x	x	x	x	x	x	x	x	x	x	Start and stop	Start / stop / free stop
23	3-line command macro 1	start up	Reverse start	stop	x	x	x	x	x	x	x	x	x	Start and stop	Start / stop / free stop
24	3-line command macro 2	start up	Forward and reverse	stop	x	x	x	x	x	x	x	x	x	Start and stop	Start / stop / free stop
30	Main and auxiliary settings	x	x	x	x	x	x	x	Feedback value	x	x	x	x	x	Set value
31	Multi-stage speed macro	x	x	x	Segment speed selection	Segment speed selection	x	x	x	x	x	x	x	x	x
32	PID Macro 1	x	x	x	x	x	x	x	Feedback value	x	x	x	x	x	x
33	PID Macro 2	x	x	x	x	x	x	x	Feedback value	Set value	x	x	x	x	x
50	Speed Start Macro	x	x	x	x	x	x	x	x	x	x	x	x	x	x
51	DC injection macro	x	x	x	x	x	x	x	x	x	x	x	x	x	x

52	Free parking macro	x	x	x	x	x	x	x	x	x	x	x	x	x	x
53	DC brake macro	x	x	x	x	x	x	x	x	x	x	x	x	x	x
54	Haste Macro	x	x	x	x	x	x	x	x	x	x	x	x	x	x
55	Jerk macro	x	x	x	x	x	x	x	x	x	x	x	x	x	x
60	Console switch macro	x	x	x	Segment speed selection	Segment speed selection	x	x	x	x	x	x	x	Set value	x
61	Frequency reach macro	x	x	x	x	Frequency reach	x	x	x	x	x	x	x	x	x
62	FDT macro	x	x	x	x	Frequency reach range	x	x	x	x	x	x	x	x	x
63	Acceleration and deceleration switching	x	x	x	x	x	x	x	x	x	x	x	x	x	x
64	Brake signal macro	x	x	x	x	Frequency too low	x	x	x	x	x	x	x	x	x
65	Slack gate signal macro	x	x	x	x	Frequency reached and the current is too large	x	x	x	x	x	x	x	x	x
66	Break detection macro	x	x	x	x	Frequency reached and current too small	x	x	x	x	x	x	x	x	x

67	Signal loss macro	x	x	x	x	x	Detection signal is less than the threshold	x	x	x	x	x	x	x	x
68	Internal control eight-stage speed macro	x	x	x	Segment speed enable	x	x	x	x	x	x	x	x	x	x

7.2 Comprehensive Macro 1

Comprehensive Macro 1 (P1.20 = 10)
<p>Multi-command source, multi-set value given mode, analog and digital output.</p> <ul style="list-style-type: none"> · Set frequency: main frequency AI1 + auxiliary frequency (multi-speed + communication). · If JOG command is valid, run JOG frequency. · Command source: start and stop, reverse start, JOG command. · Use analog quantity AI1, AO1, AO2, external terminals S1 ~ S5.

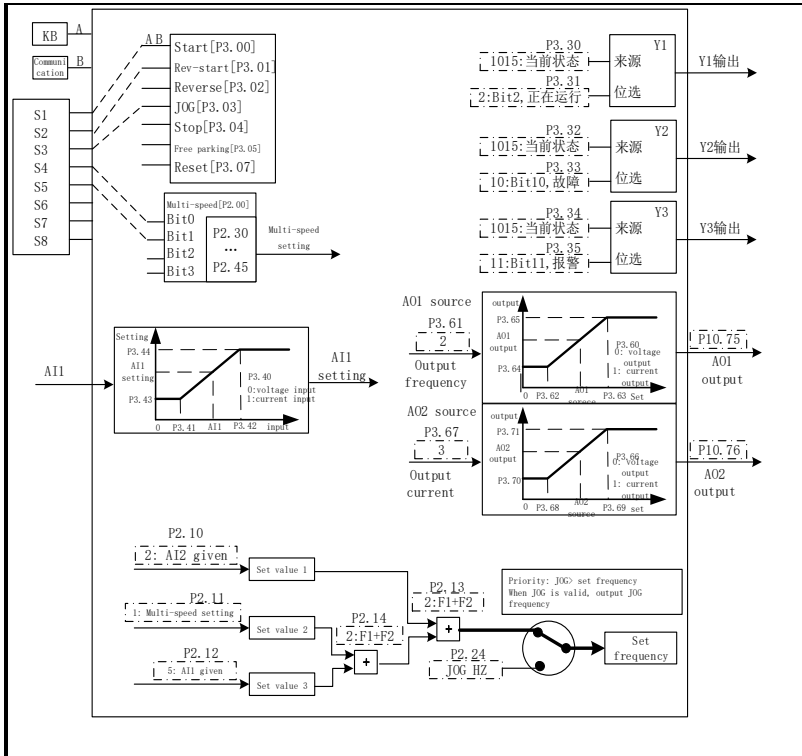

Parameter No.	Function	Setting value	Note
P2.24	Jog Frequency	10	JOG frequency is set to 5HZ
P2.30	Multi-speed 0	20	Auxiliary frequency multi-speed 0 is set to 10HZ
P2.31	Multi-speed 1	30	Auxiliary frequency multi-speed 1 is set to 15HZ
P2.32	Multi-speed 2	40	Auxiliary frequency multi-speed 2 is set to 20HZ
P2.33	Multi-speed 3	50	Auxiliary frequency multi-speed 3 is set to 25HZ
P3.61	AO1 signal source	2	Output frequency
P3.67	AO2 signal source	3	Output current
P3.40	AI1 signal type	0	AI1 signal type is voltage signal
P3.41	AI1 low-end voltage (current)	0.050	0.050V corresponds to 0HZ

P3.42	AI1 high-end voltage (current)	10.000	10.000V corresponds to 50HZ
P3.43	AI1 low-end settings	0.000	AI1 low-end settings
P3.44	AI1 high-end settings	100.000	AI1 high-end settings
P3.60	AO1 signal type	0	AO1 signal type is voltage signal
P3.62	AO1 low-end settings	0.000	AO1 low-end settings
P3.63	AO1 high-end settings	50.000	AO1 high-end settings
P3.64	AO1 low-end voltage (current)	0.000	0.000V corresponds to 0HZ
P3.65	AO1 high-end voltage (current)	10.000	10.000V corresponds to 50HZ
P3.66	AO2 signal type	0	AO2 signal type is voltage signal
P3.68	AO2 low-end settings	0.000	AO2 low-end settings
P3.69	AO2 high-end settings	50.000	AO2 high-end settings
P3.70	AO2 low-end voltage (current)	0.000	0.000V corresponds to 0HZ
P3.71	AO2 high-end voltage (current)	10.000	10.000V corresponds to 50HZ
P1.39	AI1 signal type is voltage signal	1	Multi-command source
P2.00	0.050V corresponds to 0HZ	11000	Multi-speed selection for external terminals S4, S5
P2.10	10.000V corresponds to 50HZ	2	Set value source 1 select AI1
P2.11	AI1 low-end settings	1	Set value source 2 select multi-speed
P2.12	AI1 high-end settings	5	Set value source 3 is communication
P2.13	AO1 signal type is voltage signal	2	Set the channel 1 relationship selection to F1 + F2
P2.14	AO1 low-end settings	2	Set the channel 2 relationship selection to F1 + F2
P3.00	AO1 high-end settings	7	Start command to select keyboard, communication, external terminal S1
P3.01	0.000V corresponds to 0HZ	8	Reverse start command is selected as external terminal S2
P3.03	10.000V corresponds to 50HZ	16	JOG command is selected as external terminal S3
P3.30	AO2 signal type is voltage signal	3	Relay 1 comes from the current state is running
P3.32	AO2 low-end settings	4	Relay 2 comes from current state fault
P3.34	AO2 high-end settings	5	Relay 3 comes from the current state alarm

7.3 Comprehensive Macro 2

Comprehensive Macro 2 (P1.20 = 11)
Multi-command source, multi-set value given mode, analog and digital output.

- Set frequency: The main frequency AI1 + auxiliary frequency (multi-stage speed + communication) is given.
- If JOG command is valid, run JOG frequency.
- Command source: start and stop, forward and reverse, JOG command.
- Use analog quantity AI1, AO1, AO2, external terminals S1 ~ S5.

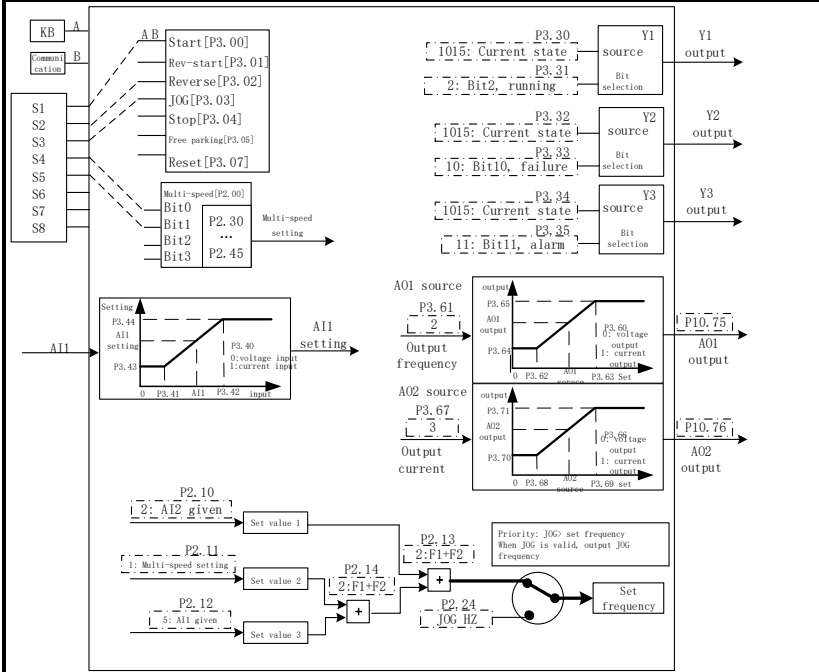

Parameter No.	Function	Setting value	Note
P2.24	JOG frequency	10	JOG frequency is set to 5HZ
P2.30	Multi-speed 0	20	Auxiliary frequency multi-speed 0 is set to 10HZ
P2.31	Multi-speed 1	30	Auxiliary frequency multi-speed 1 is set to 15HZ
P2.32	Multi-speed 2	40	Auxiliary frequency multi-speed 2 is set to 20HZ
P2.33	Multi-speed 3	50	Auxiliary frequency multi-speed 3 is set to 25HZ
P3.61	AO1 signal source	2	Output frequency
P3.67	AO2 signal source	3	Output current
P3.40	AI1 signal type	0	AI1 signal type is voltage signal
P3.41	AI1 low-end voltage (current)	0.050	0.050V corresponds to 0HZ
P3.42	AI1 high-end voltage (current)	10.000	10.000V corresponds to 50HZ

P3.43	AI1 low-end settings	0.000	AI1 low-end settings
P3.44	AI1 high-end settings	100.000	AI1 high-end settings
P3.60	AO1 signal type	0	AO1 signal type is voltage signal
P3.62	AO1 low-end settings	0.000	AO1 low-end settings
P3.63	AO1 high-end settings	50.000	AO1 high-end settings
P3.64	AO1 low-end voltage (current)	0.000	0.000V corresponds to 0HZ
P3.65	AO1 high-end voltage (current)	10.000	10.000V corresponds to 50HZ
P3.66	AO2 signal type	0	AO2 signal type is voltage signal
P3.68	AO2 low-end settings	0.000	AO2 low-end settings
P3.69	AO2 high-end settings	50.000	AO2 high-end settings
P3.70	AO2 low-end voltage (current)	0.000	0.000V corresponds to 0HZ
P3.71	AO2 high-end voltage (current)	10.000	10.000V corresponds to 50HZ
P1.39	Command format	1	Multi-command source
P2.00	Multi-speed source	11000	Multi-speed selection is S4, S5
P2.10	Setpoint source 1	2	Set value source 1 to AI1
P2.11	Set value source 2	1	Set value source 2 is multi-speed
P2.12	Setpoint source 3	5	Set value source 3 is communication
P2.13	Set channel 1 relationship selection	2	Set the channel 1 relationship selection to F1 + F2
P2.14	Set channel 2 relationship selection	2	Set the channel 2 relationship selection to F1 + F2
P3.00	Start command source	7	Start command selection is keyboard, communication, external terminal S1
P3.02	Reverse command source	8	Reverse command selection is external terminal S2
P3.03	JOG command source	16	JOG command is selected as external terminal S3
P3.30	Y1 terminal source	3	Relay 1 comes from the current state is running
P3.32	Y2 terminal source	4	Relay 2 comes from current state fault
P3.34	Y3 terminal source	5	Relay 3 comes from the current state alarm

7.4 Comprehensive Macro 3

Comprehensive Macro 3 (P1.20 = 12)
<p>Multi-command source, multi-set value given mode, analog and digital output.</p> <ul style="list-style-type: none"> · Set frequency: The main frequency AI1 + auxiliary frequency (multi-stage speed + communication) is given. · Command source: start stop, stop, forward and reverse. · Use analog quantity AI1, AO1, AO2, external terminals S1 ~ S5.

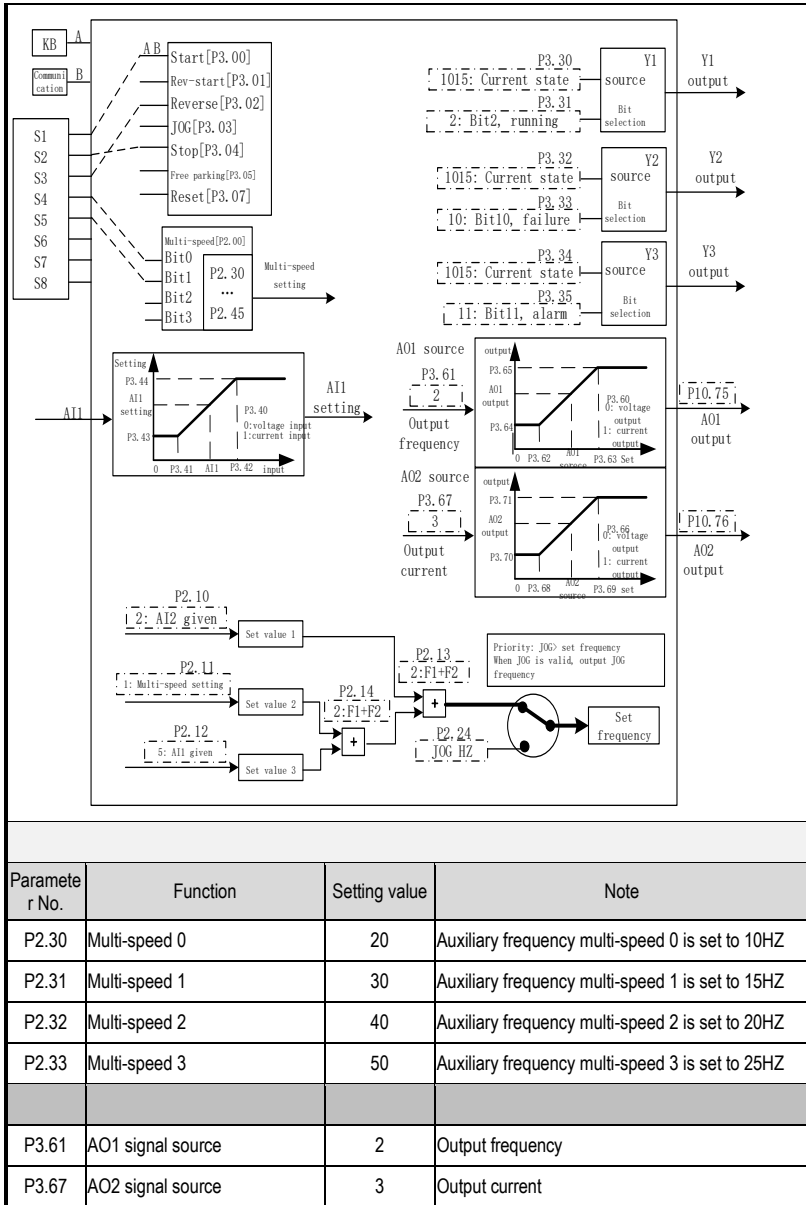

Parameter No.	Function	Setting value	Note
P2.30	Multi-speed 0	20	Auxiliary frequency multi-speed 0 is set to 10HZ
P2.31	Multi-speed 1	30	Auxiliary frequency multi-speed 1 is set to 15HZ
P2.32	Multi-speed 2	40	Auxiliary frequency multi-speed 2 is set to 20HZ
P2.33	Multi-speed 3	50	Auxiliary frequency multi-speed 3 is set to 25HZ
P3.61	A01 signal source	2	Output frequency
P3.67	A02 signal source	3	Output current

P3.40	AI1 signal type	0	AI1 signal type defaults to voltage signal
P3.41	AI1 low-end voltage (current)	0.050	0.050V corresponds to 0HZ
P3.42	AI1 high-end voltage (current)	10.000	10.000V corresponds to 50HZ
P3.43	AI1 low-end settings	0.000	AI1 low-end settings
P3.44	AI1 high-end settings	100.000	AI1 high-end settings
P3.60	AO1 signal type	0	AO1 signal type is voltage signal
P3.62	AO1 low-end settings	0.000	AO1 low-end settings
P3.63	AO1 high-end settings	50.000	AO1 high-end settings
P3.64	AO1 low-end voltage (current)	0.000	0.000V corresponds to 0HZ
P3.65	AO1 high-end voltage (current)	10.000	10.000V corresponds to 50HZ
P3.66	AO2 signal type	0	AO2 signal type is voltage signal
P3.68	AO2 low-end settings	0.000	AO2 low-end settings
P3.69	AO2 high-end settings	50.000	AO2 high-end settings
P3.70	AO2 low-end voltage (current)	0.000	0.000V corresponds to 0HZ
P3.71	AO2 high-end voltage (current)	10.000	10.000V corresponds to 50HZ
P1.39	Command format	1	Multi-command source
P2.00	Multi-speed source	11000	Multi-speed selection for external terminals S4, S5
P2.10	Setpoint source 1	2	Set value source 1 to AI1
P2.11	Set value source 2	1	Set value source 2 is multi-speed
P2.12	Setpoint source 3	5	Set value source 3 is communication
P2.13	Set channel 1 relationship selection	2	Set the channel 1 relationship selection to F1 + F2
P2.14	Set channel 2 relationship selection	2	Set the channel 2 relationship selection to F1 + F2
P3.00	Start command source	7	Start command selection is keyboard, communication, external terminal S1
P3.04	Source of stop command	8	Stop command is selected as external terminal S2
P3.02	Reverse command source	16	Reverse command selection is external terminal S3
P3.30	Y1 terminal source	3	Relay 1 comes from the current state is running

P3.32	Y2 terminal source	4	Relay 2 comes from current state fault
P3.34	Y3 terminal source	5	Relay 3 comes from the current state alarm

7.5 Comprehensive Macro 4

Comprehensive Macro 4 (P1.20 = 13)
<p>Multi-command source, PID main and auxiliary setting value given mode, analog and digital output.</p> <ul style="list-style-type: none"> · Set frequency: The main frequency AI2 + auxiliary frequency PID is given. PID setting: multi-step speed, PID feedback: AI1. · If JOG command is valid, run JOG frequency. · Command source: start stop, stop, JOG command. · Use analog AI1, AI2, AO1, AO2, external terminals S1 ~ S3.

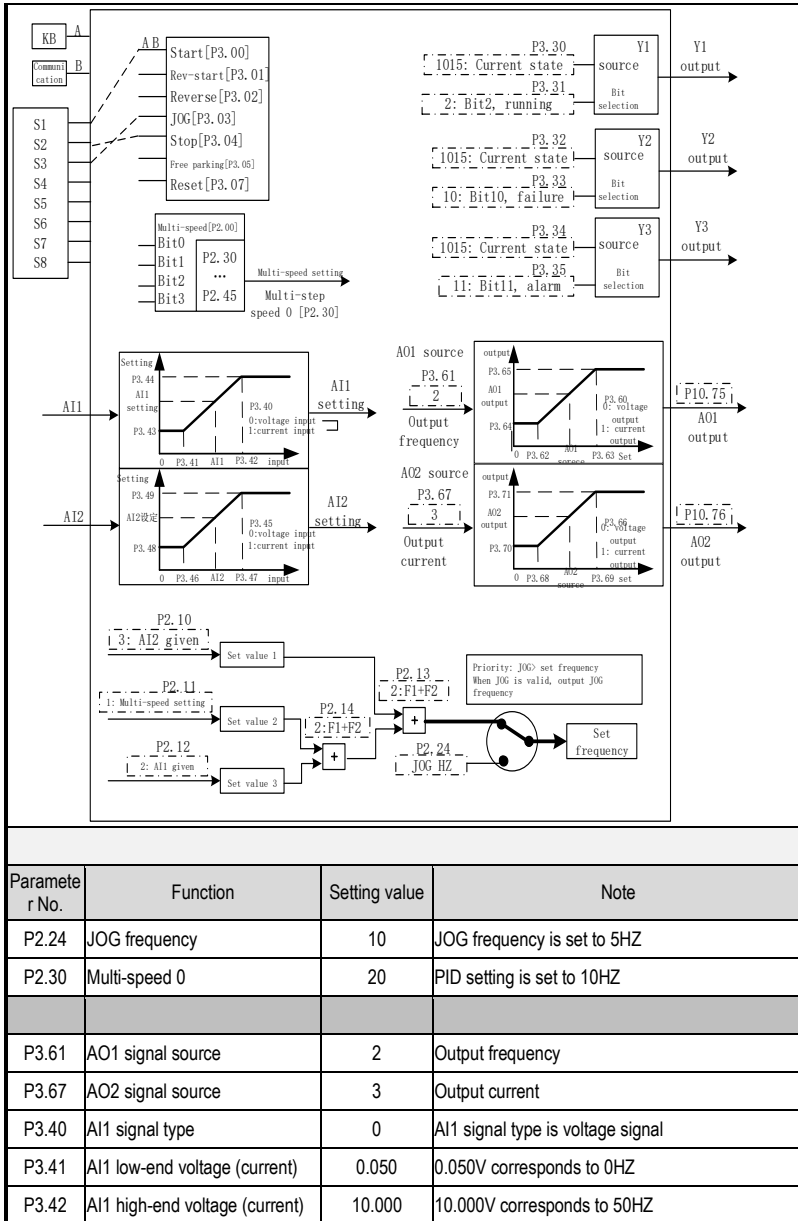

P3.43	AI1 low-end settings	0.000	AI1 low-end settings
P3.44	AI1 high-end settings	100.000	AI1 high-end settings
P3.45	AI2 signal type	0	AI2 signal type is voltage signal
P3.46	AI2 low-end voltage (current)	0.050	0.050V corresponds to 0HZ
P3.47	AI2 high-end voltage (current)	10.000	10.000V corresponds to 50HZ
P3.48	AI2 low-end settings	0.000	AI2 low-end settings
P3.49	AI2 high-end settings	50.000	AI2 high-end settings
P3.60	AO1 signal type	0	AO1 signal type is voltage signal
P3.62	AO1 low-end settings	0.000	AO1 low-end settings
P3.63	AO1 high-end settings	50.000	AO1 high-end settings
P3.64	AO1 low-end voltage (current)	0.000	0.000V corresponds to 0HZ
P3.65	AO1 high-end voltage (current)	10.000	10.000V corresponds to 50HZ
P3.66	AO2 signal type	0	AO2 signal type is voltage signal
P3.68	AO2 low-end settings	0.000	AO2 low-end settings
P3.69	AO2 high-end settings	50.000	AO2 high-end settings
P3.70	AO2 low-end voltage (current)	0.000	0.000V corresponds to 0HZ
P3.71	AO2 high-end voltage (current)	10.000	10.000V corresponds to 50HZ
P1.39	Command format	1	Multi-command source
P2.00	Multi-speed source	0	Multi-speed selection without external terminals
P2.10	Setpoint source 1	3	Set value source 1 to AI2
P2.11	Set value source 2	1	Set value source 2 is multi-speed
P2.12	Setpoint source 3	2	Set value source 3 to AI1
P2.13	Set channel 1 relationship selection	2	Set the channel 1 relationship selection to F1 + F2
P2.14	Set channel 2 relationship selection	8	Set the channel 2 relationship selection to PID
P3.00	Start command source	7	Start command selection is keyboard, communication, external terminal S1
P3.04	Source of stop command	8	Stop command is selected as external terminal S2
P3.03	JOG command source	16	JOG command is selected as external terminal S3
P3.30	Y1 terminal source	3	Relay 1 comes from the current state is running
P3.32	Y2 terminal source	4	Relay 2 comes from current state fault
P3.34	Y3 terminal source	5	Relay 3 comes from the current state alarm

1-Line command macro

1-Line command macro (P1.20=20)

S1 controls start and stop.

- The source of the command includes start and stop and free stop.
- Use external terminal S1.

The diagram shows a central box representing the inverter's command interface. On the left, there are two input sources: 'KB' (Keyboard) and 'Communication'. 'KB' is connected to terminal 'A', and 'Communication' is connected to terminal 'B'. Below these are eight external terminals labeled 'S1' through 'S8'. A dashed line connects terminal 'S1' to the 'Start' terminal of the central box. The central box has several output terminals: 'Start [P3.00]', 'Rev-start [P3.01]', 'Reverse [P3.02]', 'JOG [P3.03]', 'STOP [P3.04]', 'Free parking [P3.05]', and 'Reset [P3.07]'. A terminal labeled 'B' is also shown on the left side of the central box, which is connected to the 'Free parking' terminal.

Parameter No.	Function	Setting value	Note
P2.91	Communication commands	0	0 is no command; 1 is start command; 32 is free stop
P1.39	Command format	1	Multi-command source
P3.00	Start command source	7	Start command selection is keyboard, communication, external terminal S1
P3.04	Source of stop command	0	No effect
P3.05	Free parking order source	2	Free stop command is selected for communication

2-Line command macro 1

2-Line command macro 1 (P1.20=21)

S1 controls forward rotation and S2 controls reverse rotation.
 · Command sources include start and stop, reverse start, and free stop.
 · Use external terminals S1 ~ S2.

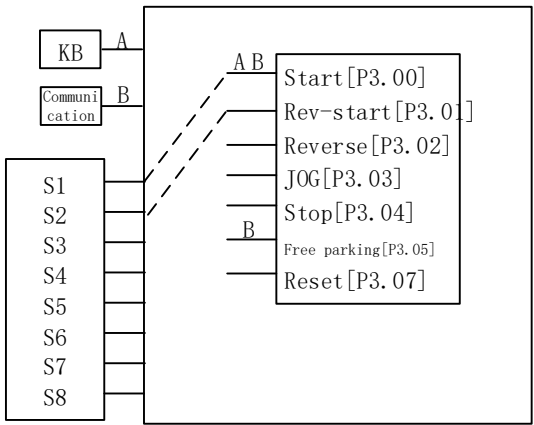

Parameter No.	Function	Setting value	Note
P1.39	Command format	1	Multi-command source
P3.00	Start command source	7	Start command selection is keyboard, communication, external terminal S1
P3.01	Reverse start command source	8	Reverse start command is selected as external terminal S2
P3.04	Source of stop command	0	No effect
P3.05	Free parking order source	2	Free stop command is selected for communication

2-Line command macro 2

2-Line command macro 2 (P1.20 = 22)

S1 controls start and stop, S2 controls direction.
 · The command sources include start and stop, forward and reverse, and free stop.
 · Use external terminals S1 ~ S2.

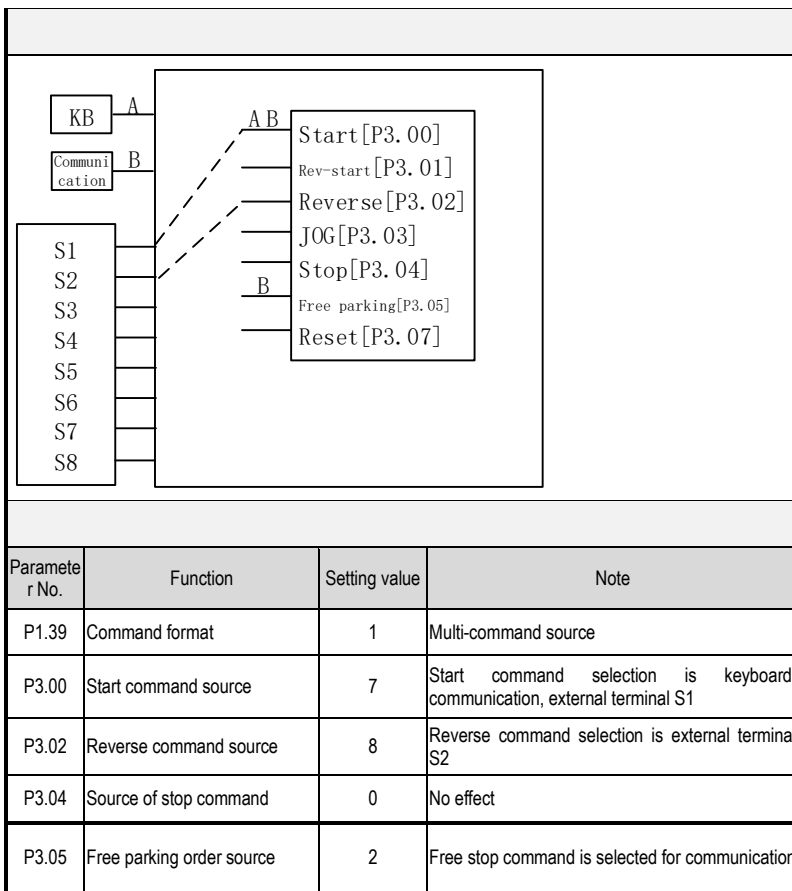

3-Line command macro 1

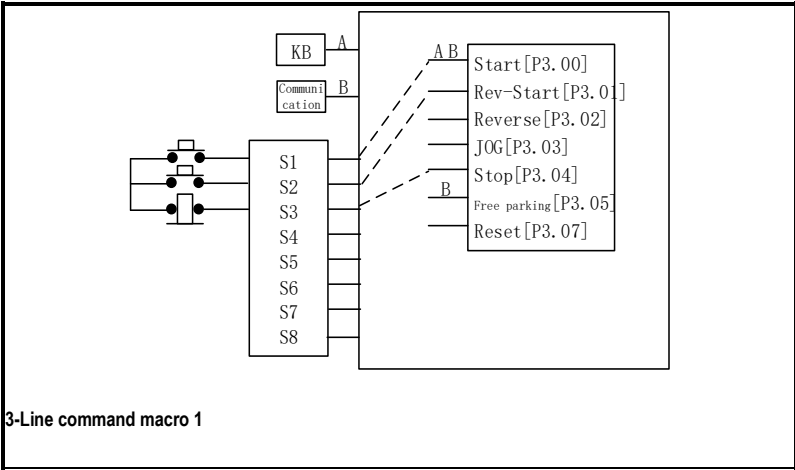

3-Line command macro 1

Three-wire system.
 · The command sources include start, reverse start, stop and free stop.
 · Use external terminals S1 ~ S3.

Parameter No.	Function	Setting value	Note
P1.39	Command format	1	Multi-command source
P3.00	Start command source	7	Start command selection is keyboard, communication, external terminal S1
P3.01	Reverse start command source	8	Reverse start command is selected as external terminal S2
P3.04	Source of stop command	16	Stop command is selected as S3 terminal
P3.05	Free parking order source	2	Free stop command is selected for communication
P3.20	S1 type	2	Trigger on rising edge
P3.21	S2 type	2	Trigger on rising edge
P3.22	S3 type	3	Trigger on falling edge

3-Line command macro 2

3-Line command macro 2

Three-wire system.

- The command sources include start and stop, forward and reverse, stop and free stop.
- Use external terminals S1 ~ S3.

Parameter No.	Function	Setting value	Note
P1.39	Command format	1	Command format
P3.00	Start command source	7	Start command source
P3.02	Reverse command source	8	Reverse command source
P3.04	Source of stop command	16	Source of stop command
P3.05	Free parking order source	2	Free parking order source
P3.20	S1 type	2	S1 type
P3.22	S3 type	3	S3 type

Main and auxiliary settings

Main and auxiliary settings (P1.20 = 30)

Various setting values are added and given.

- The set frequency is given by the main frequency AI1 + auxiliary frequency (multi-stage speed + communication).
- No command source is given.
- No external terminals are used.

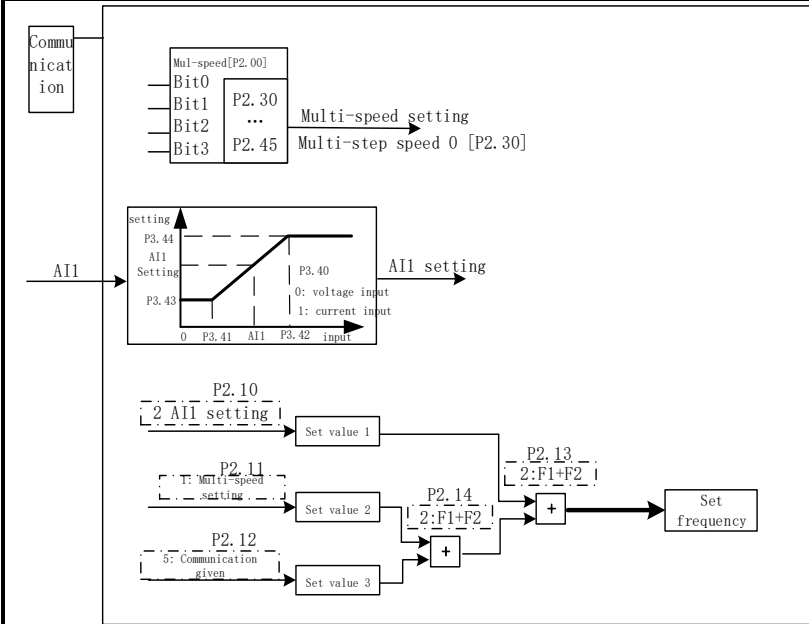

Parameter No.	Function	Setting value	Note
P2.30	Multi-speed 0	20	Auxiliary frequency multi-speed 0 is set to 10HZ
P3.40	AI1 signal type	0	AI1 signal type is voltage signal
P3.41	AI1 low-end voltage (current)	0.050	0.050V corresponds to 0HZ
P3.42	AI1 high-end voltage (current)	10.000	10.000V corresponds to 50HZ
P3.43	AI1 low-end settings	0.000	AI1 low-end settings
P3.44	AI1 high-end settings	100.000	AI1 high-end settings
P2.10	Setpoint source 1	2	Set value source 1 to AI1

P2.11	Set value source 2	1	Set value source 2 is multi-speed
P2.12	Setpoint source 3	5	Set value source 3 is communication
P2.13	Set channel 1 relationship selection	2	Set the channel 1 relationship selection to F1 + F2
P2.14	Set channel 2 relationship selection	2	Set the channel 2 relationship selection to F1 + F2
P2.00	Multi-speed source	0	Multi-speed selection without external terminals

Multi-speed macro

Multi-stage speed macro (P1.20=31)

Externally controlled four-speed.

- The set frequency is given by multi-step speed.
- Use external terminals S4 ~ S5.

Paramet er No.	Function	Setting value	Note
P2.30	Multi-speed 0	20	Multi-speed 0 is set to 10HZ
P2.31	Multi-speed 1	30	Multi-speed 1 is set to 15HZ
P2.32	Multi-speed 2	40	Multi-speed 2 is set to 20HZ
P2.33	Multi-speed 3	50	Multi-speed 3 is set to 25HZ
P2.10	Setpoint source 1	1	Set value source 1 is multi-speed

P2.13	Set channel 1 relationship selection	0	Set channel 1 relationship to F1
P2.00	Multi-speed source	11000	Multi-speed selection for external terminals S4, S5

PID Macro 1

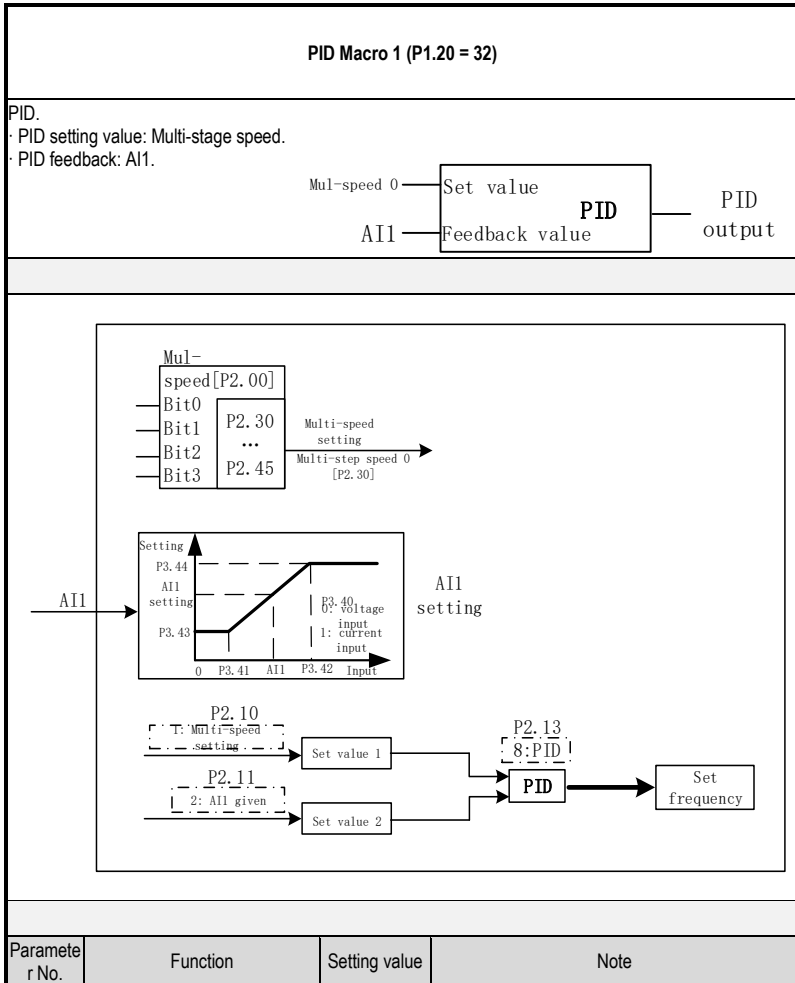

P2.30	Multi-speed 0	20	PID setting
P3.40	AI1 signal type	0	AI1 signal type is voltage signal
P3.41	AI1 low-end voltage (current)	0.050	PID feedback signal lower limit
P3.42	AI1 high-end voltage (current)	10.000	PID feedback signal upper limit
P3.43	AI1 low-end settings	0.000	PID feedback value lower limit
P3.44	AI1 high-end settings	100.000	PID feedback value upper limit
P2.10	Setpoint source 1	1	Set value source 1 is multi-speed
P2.11	Set value source 2	2	Set value source 2 to AI1
P2.13	Set channel 1 relationship selection	8	Set channel 1 relationship to PID
P2.00	Multi-speed source	0	Multi-speed selection without external terminals

PID Macro 2

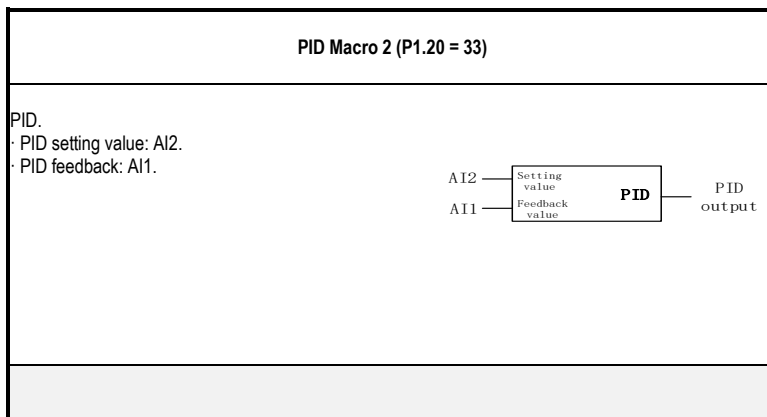

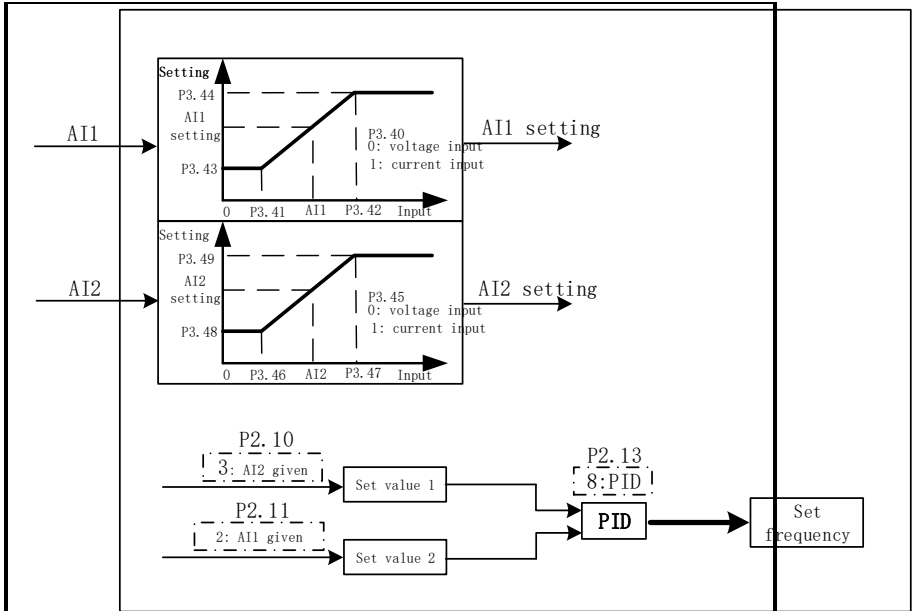

Parameter No.	Function	Setting value	Note
P3.40	AI1 signal type	0	AI1 signal type is voltage signal
P3.41	AI1 low-end voltage (current)	0.050	PID feedback signal lower limit
P3.42	AI1 high-end voltage (current)	10.000	PID feedback signal upper limit
P3.43	AI1 low-end settings	0.000	PID feedback value lower limit
P3.44	AI1 high-end settings	100.000	PID feedback value upper limit
P3.45	AI2 signal type	0	AI2 signal type is voltage signal

P3.46	AI2 low-end voltage (current)	0.050	PID setting signal lower limit
P3.47	AI2 high-end voltage (current)	10.000	PID setting signal upper limit
P3.48	AI2 low-end settings	0.000	Lower limit of PID setting
P3.49	AI2 high-end settings	100.000	PID setting upper limit
P2.10	Setpoint source 1	3	Set value source 1 to AI2
P2.11	Set value source 2	2	Set value source 2 to AI1
P2.13	Set channel 1 relationship selection	8	Set channel 1 relationship to PID
P2.00	Multi-speed source	0	Multi-speed selection without external terminals

Speed Start Macro

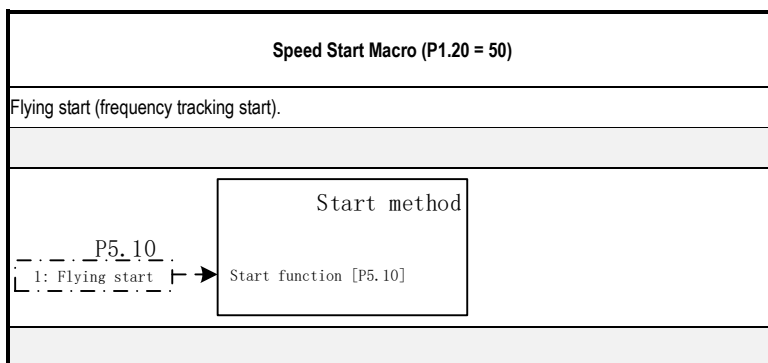

Parameter No.	Function	Setting value	Note
P5.10	Start function	1	The start function is the speed start

DC injection macro

DC injection macro (P1.20 = 51)			
DC injection starts.			
Parameter No.	Function	Setting value	Note
P5.10	Start function	2	Start function is DC injection

Free Parking Macro

Macro of free parking (P1.20 = 52)			
Free parking.			
Parameter No.	Function	Setting value	Note
P5.20	Stop function	0	Stop function for free stop
P5.21	Stop frequency	100.000	Stop frequency is set to 100.000Hz

DC braking macro

DC braking macro (P1.20 = 53)			
DC braking stops.			
Parameter No.	Function	Setting value	Note
P5.20	Stop function	1	Stop function is DC braking
P5.21	Stop frequency	3	Stop frequency is set to 3Hz

Haste Macro

Rapid acceleration macro (P1.20 = 54)			
Quick Start.			

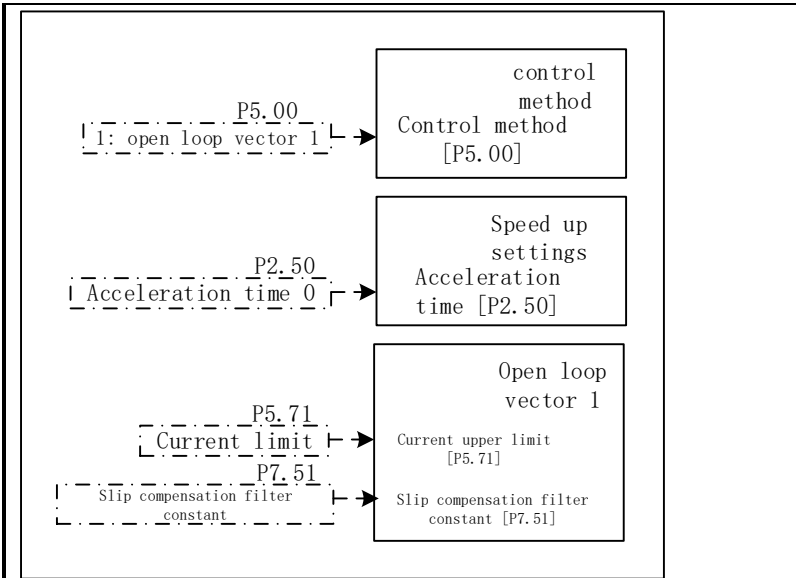

Parameter No.	Function	Setting value	Note
P2.50	Acceleration time 0	1	The acceleration time is set to 1s
P5.00	control method	1	Select open loop vector 1
P5.71	Current limit	160	The current limit is set to 160%
P7.51	Slip compensation filter constant	150	The slip compensation filter is set to 150%

Sudden Deceleration Macro

Rapid deceleration macro (P1.20 = 55)
Stop quickly.

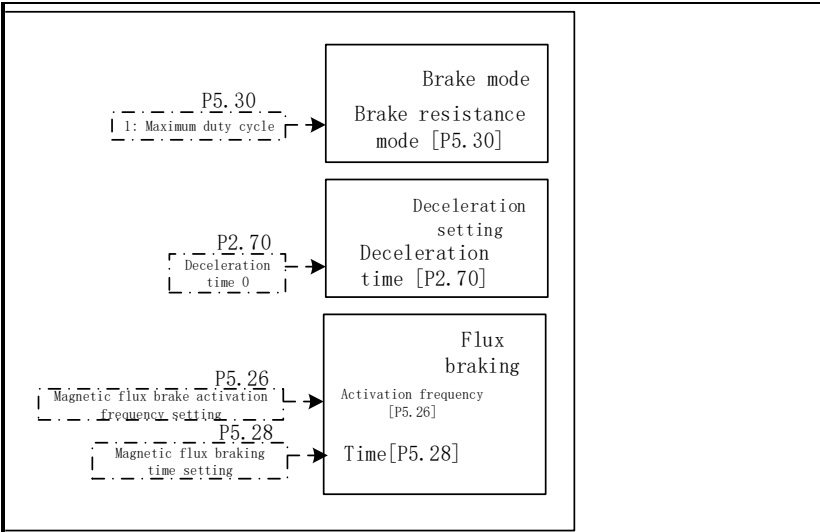

Parameter No.	Function	Setting value	Note
P2.70	Deceleration time 0	1	Deceleration time is set to 1s
P5.26	Magnetic flux brake activation frequency	100	The flux brake activation frequency is set to 100%
P5.28	Flux braking time	3	The flux braking time is set to 3s
P5.71	Current limit	180	The current limit is set to 180%
P5.30	Brake resistance mode	1	Choose the maximum duty cycle

Control terminal switching macro

Control terminal switching macro (P1.20 = 60)

When there is multi-speed signal, it is given by multi-speed, and when there is no multi-speed signal, it is given by keyboard.

- The setting frequency can be selected by multi-speed or keyboard.
- Use external terminals S4 and S5.

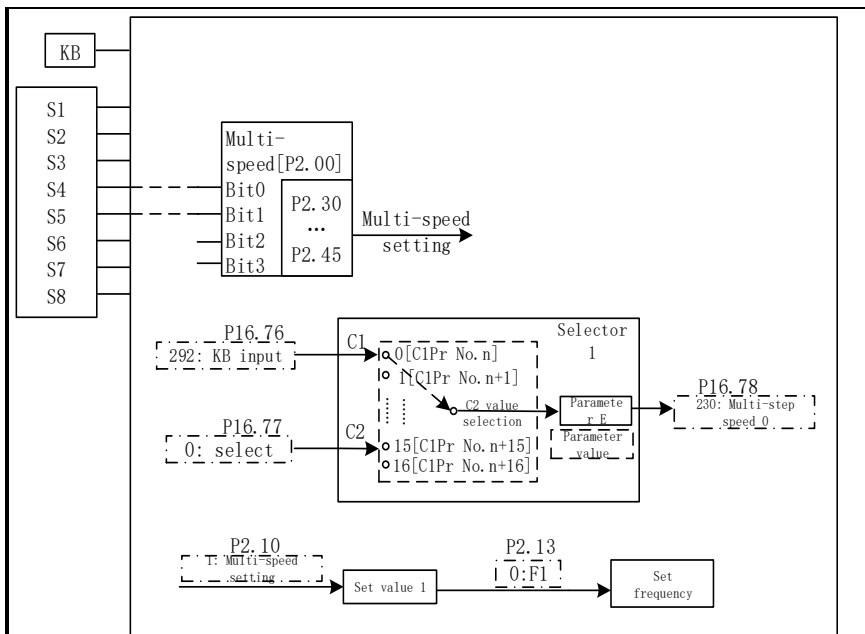

Parameter No.	Function	Setting value	Note
P2.92	Keyboard settings	*	Source keyboard potentiometer
P2.31	Multi-speed 1	30	Multi-speed 1 is set to 15HZ
P2.32	Multi-speed 2	40	Multi-speed 2 is set to 20HZ
P2.33	Multi-speed 3	50	Multi-speed 3 is set to 25HZ
P16.76	Selector 1 parameter source	292	Selector 1 parameter source is keyboard setting value
P16.77	Selector 1 setting	0	Selector 1 is set to 0
P16.78	Selector 1 destination parameters	230	The purpose parameter of selector 1 is multi-speed
P2.10	Setpoint source 1	1	Set value source 1 is multi-speed
P2.13	Set channel relationship selection	0	Set the channel relationship selection to F1
P2.00	Multi-speed source	11000	Multi-speed selection for external terminals S4, S5

Frequency arrival macro

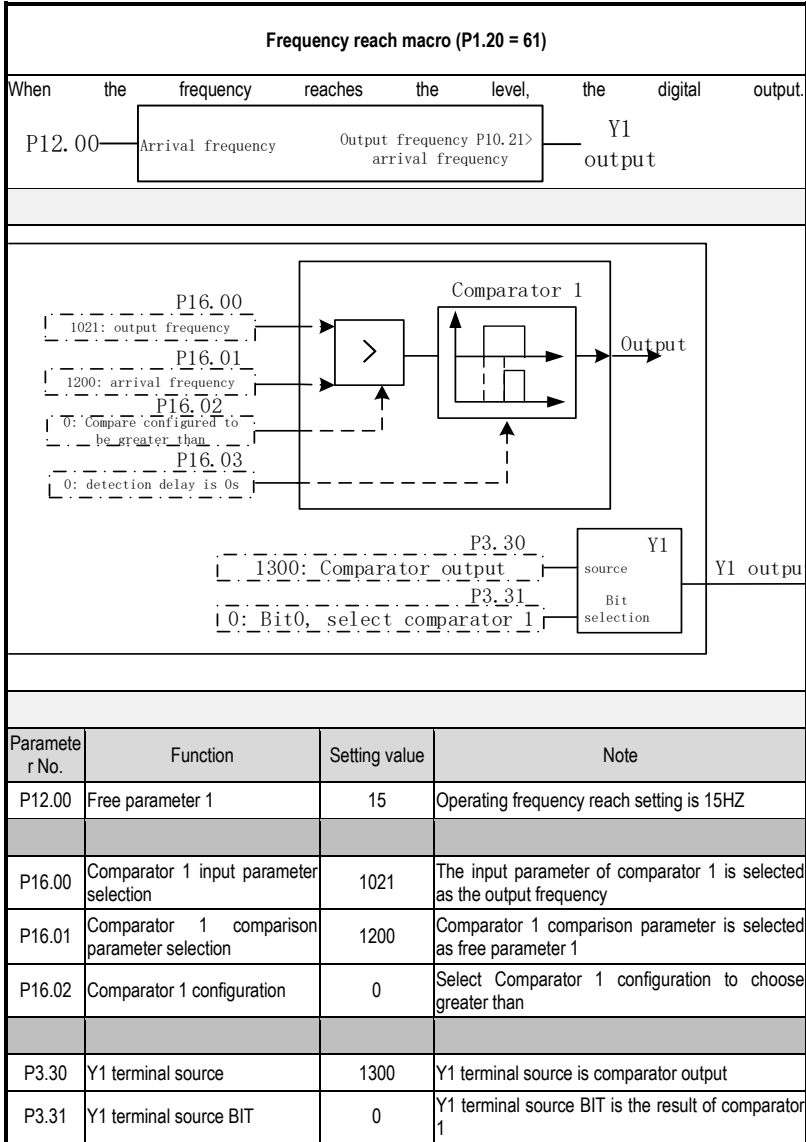

FDT macro

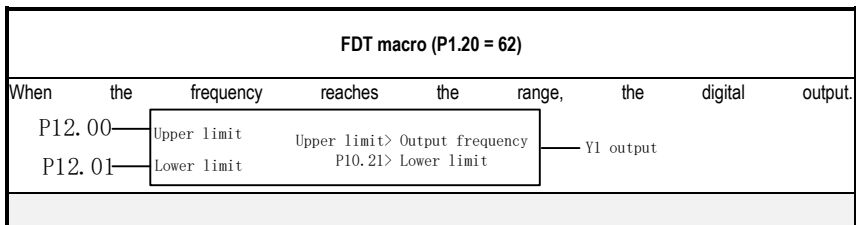

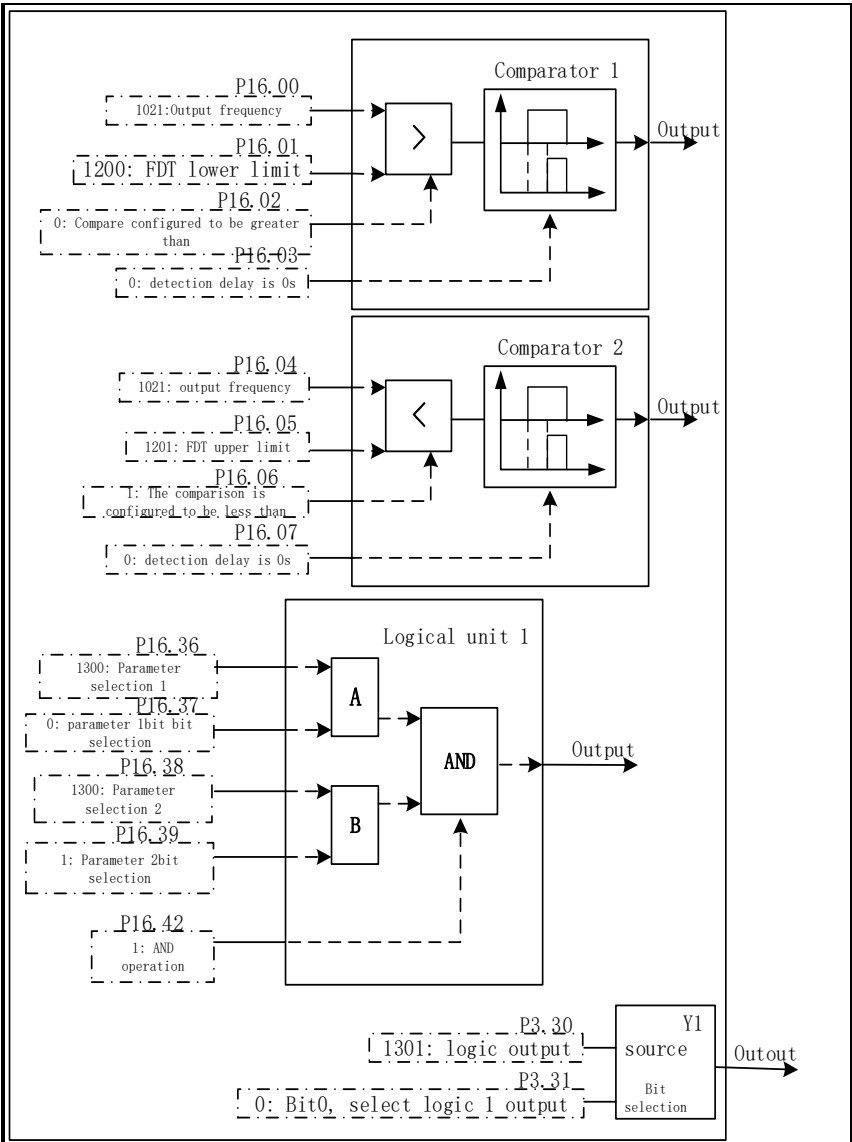

Parameter No.	Function	Setting value	Note
---------------	----------	---------------	------

P12.00	Free parameter 1	20	The lower limit of FDT is set to 20HZ
P12.01	Free parameter 2	35	The upper limit of FDT is set to 35HZ
P16.00	Comparator 1 input parameter selection	1021	The input parameter of comparator 1 is selected as the output frequency
P16.01	Comparator 1 comparison parameter selection	1200	Comparator 1 comparison parameter is selected as free parameter 1
P16.02	Comparator 1 configuration	0	Select Comparator 1 configuration to choose greater than
P16.04	Comparator 2 input parameter selection	1021	The input parameter of comparator 2 is selected as the output frequency
P16.05	Comparator 2 comparison parameter selection	1201	Comparator 2 comparison parameter is selected as free parameter 1
P16.06	Comparator 2 configuration	1	Select Comparator 2 configuration to select less than
P16.36	Logic unit 1 parameter selection 1	1300	Logic unit 1 parameter selection 1 is the comparator output
P16.37	Logic unit 1 input bit selection 1	0	Logic unit 1 input bit is selected as comparator 1
P16.38	Logic unit 1 parameter selection 2	1300	Logic unit 1 parameter selection 2 is the comparator output
P16.39	Logic unit 1 input bit selection 2	1	Logic unit 1 input bit selection 2 is comparator 2
P16.42	Logical unit 1 configuration 1	1	Logical unit 1 is configured with
P3.30	Y1 terminal source	1301	Y1 terminal source is logic output
P3.31	Y1 terminal source BIT	0	Y1 terminal source BIT bit is the result of logic unit 1

Acceleration / deceleration switching macro

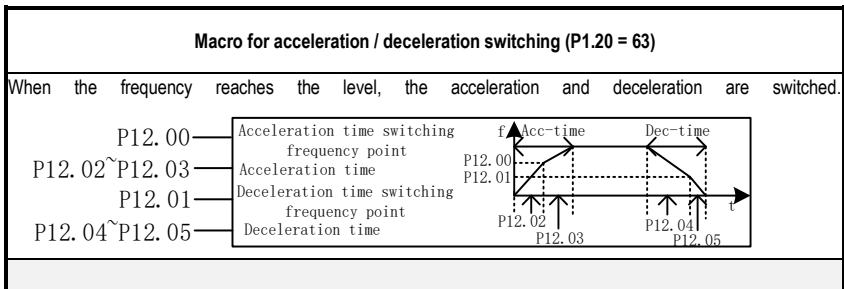

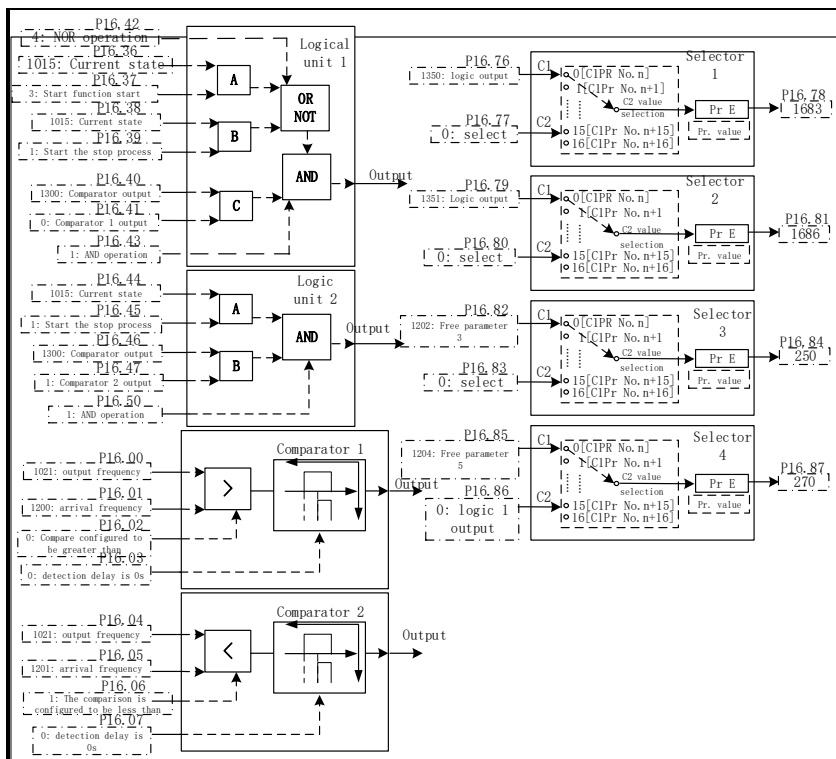

Parameter No.	Function	Setting value	Note
P12.00	Free parameter 1	15	The acceleration time switching frequency point is set to 15HZ
P12.01	Free parameter 2	10	Deceleration time switching frequency point is set to 10HZ
P12.02	Free parameter 3	5	The default acceleration time is set to 5s
P12.03	Free parameter 4	3	Switch acceleration time is set to 3s
P12.04	Free parameter 5	5	The default deceleration time is set to 5s
P12.05	Free parameter 6	8	Switching deceleration time is set to 8s
P16.00	Comparator 1 input parameter selection	1021	Output frequency
P16.01	Comparator 1 comparison parameter selection	1200	Acceleration time switching frequency point

P16.02	Comparator 1 configuration	0	Configuration selection is greater than
P16.04	Comparator 2 input parameter selection	1021	Output frequency
P16.05	Comparator 2 comparison parameter selection	1201	Deceleration time switching frequency point
P16.06	Comparator 2 configuration	1	Configuration selection is less than
P16.36	Logic unit 1 parameter selection 1	1015	Current status
P16.37	Logic unit 1 input bit selection 1	3	Start function start
P16.38	Logic unit 1 parameter selection 2	1015	Current status
P16.39	Logic unit 1 input bit selection 2	1	Stop process starts
P16.40	Logic unit 1 parameter selection 3	1300	Comparator output
P16.41	Logic unit 1 input bit selection 3	0	Comparator 1 output
P16.42	Logical unit 1 configuration 1	4	Configuration 1 is NOR
P16.43	Logical unit 1 configuration 2	1	Configuration 2 is with
P16.44	Logic unit 2 parameter selection 1	1015	Current status
P16.45	Logic unit 2 input bit selection 1	1	Stop process starts
P16.46	Logic unit 2 parameter selection 2	1300	Comparator output
P16.47	Logic unit 2 input bit selection 2	1	Comparator 2 output
P16.50	Logical unit 2 configuration 1	1	Configuration 1 is with
P16.76	Selector 1 parameter source	1350	Logic output 1
P16.77	Selector 1 setting	0	Logical choice
P16.78	Selector 1 destination parameters	1683	Selector 3 settings
P16.79	Selector 2 parameter source	1351	Logic output 2
P16.80	Selector 2 settings	0	Logical choice
P16.81	Selector 2 destination parameters	1686	Selector 4 settings
P16.82	Selector 3 parameter source	1202	Default acceleration time
P16.83	Selector 3 settings	0	Acceleration time selection
P16.84	Selector 3 destination parameters	250	Acceleration time 0
P16.85	Selector 4 parameter source	1204	Default deceleration time
P16.86	Selector 4 settings	0	Deceleration time selection
P16.87	Selector 4 destination parameters	270	Deceleration time 0

Brake signal macro

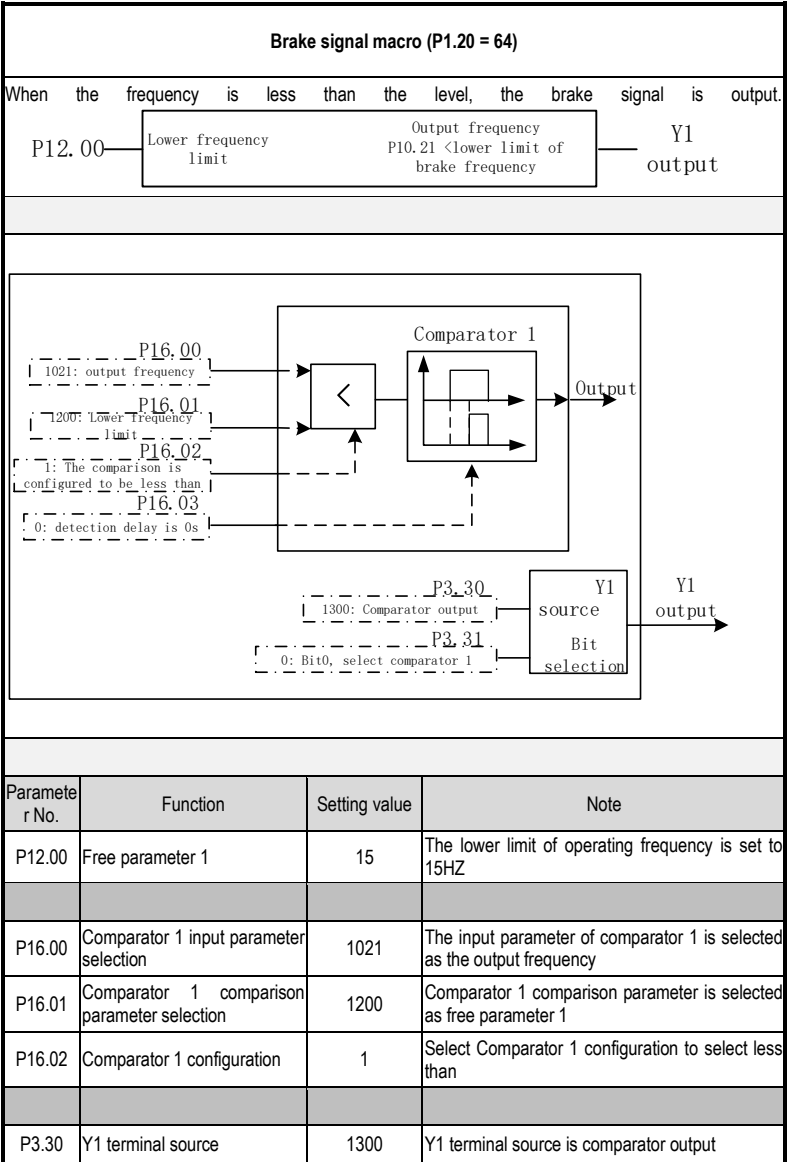

P3.31	Y1 terminal source BIT	0	Y1 terminal source BIT is the result of comparator 1
-------	------------------------	---	--

6.16 Release brake signal macro

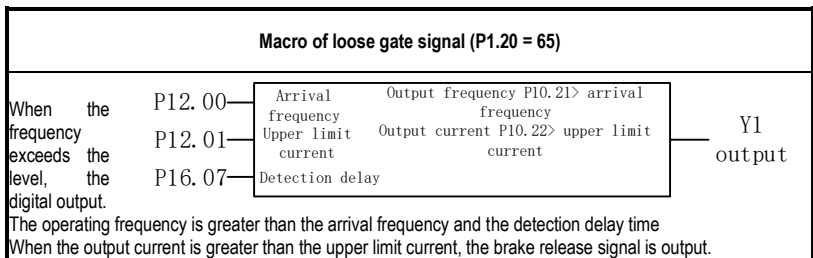

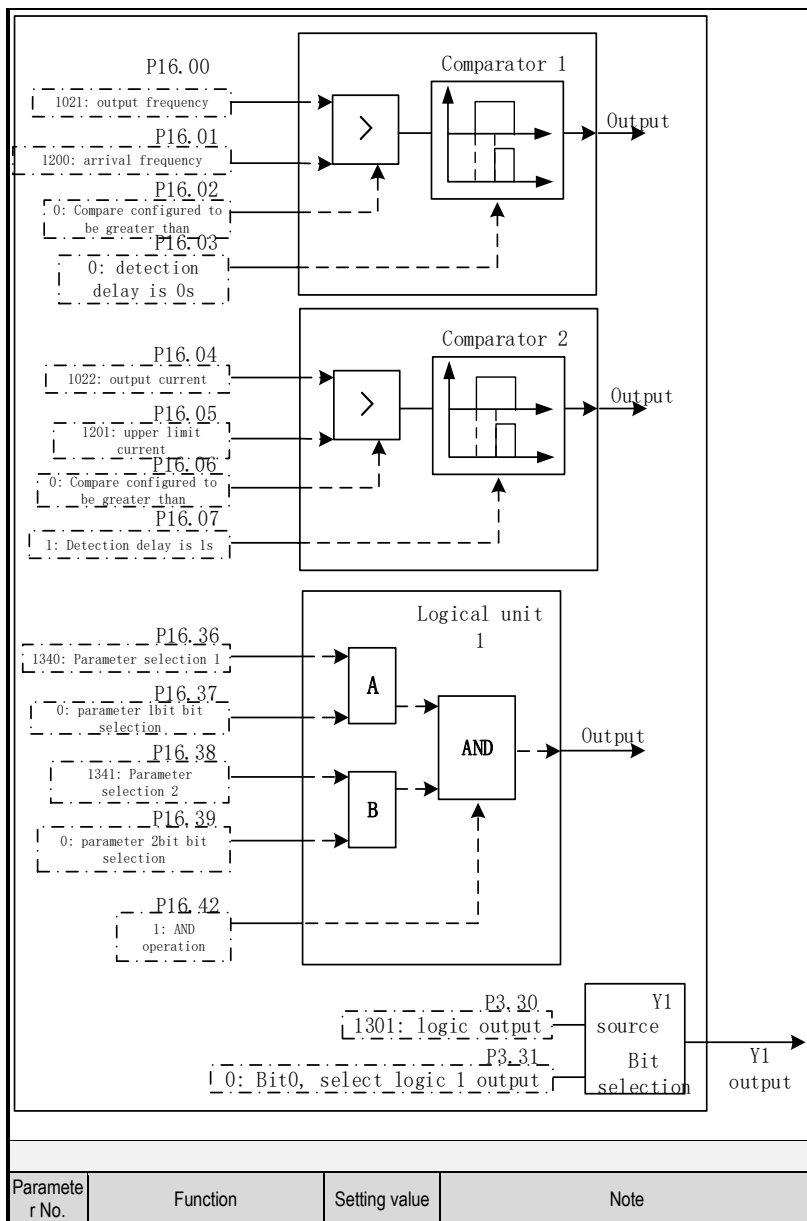

P12.00	Free parameter 1	25	Arrival frequency is set to 25HZ
P12.01	Free parameter 2	15	The upper limit current is set to 15A
P16.00	Comparator 1 input parameter selection	1021	The input parameter of comparator 1 is selected as the output frequency
P16.01	Comparator 1 comparison parameter selection	1200	Comparator 1 comparison parameter is selected as free parameter 1
P16.02	Comparator 1 configuration	0	Select Comparator 1 configuration to choose greater than
P16.04	Comparator 2 input parameter selection	1022	The input parameter of comparator 2 is selected as the output current
P16.05	Comparator 2 comparison parameter selection	1201	Comparator 2 comparison parameter is selected as free parameter 2
P16.06	Comparator 2 configuration	0	Select Comparator 2 configuration to choose greater than
P16.07	Comparator 2 delay time	1	Comparator 2 delay time is 1S
P16.36	Logic unit 1 parameter selection 1	1340	Logic unit 1 parameter selection 1 is the comparator output
P16.37	Logic unit 1 input bit selection 1	0	Logic unit 1 input bit is selected as comparator 1
P16.38	Logic unit 1 parameter selection 2	1341	Logic unit 1 parameter selection 2 is the comparator output
P16.39	Logic unit 1 input bit selection 2	0	Logic unit 1 input bit selection 2 is comparator 2
P16.42	Logical unit 1 configuration 1	1	Logical unit 1 is configured with
P3.30	Y1 terminal source	1301	Y1 terminal source is logic output
P3.31	Y1 terminal source BIT	0	Y1 terminal source BIT bit is the result of logic unit 1

Break Band Detection Macro

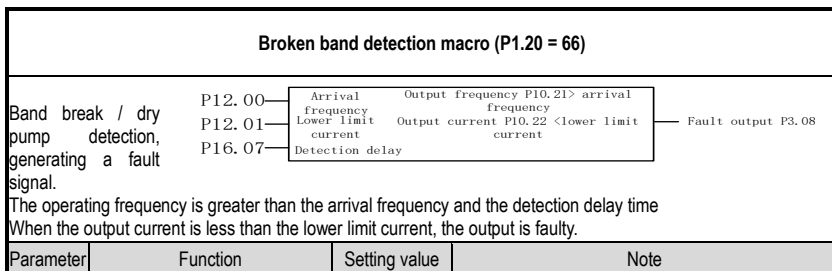

No.			
P12.00	Free parameter 1	25	Arrival frequency is set to 25HZ
P12.01	Free parameter 2	5	The lower limit current is set to 5A
P16.00	Comparator 1 input parameter selection	1021	The input parameter of comparator 1 is selected as the output frequency
P16.01	Comparator 1 comparison parameter selection	1200	Comparator 1 comparison parameter is selected as free parameter 1
P16.02	Comparator 1 configuration	0	Select Comparator 1 configuration to choose greater than
P16.04	Comparator 2 input parameter selection	1022	The input parameter of comparator 2 is selected as the output current
P16.05	Comparator 2 comparison parameter selection	1201	Comparator 2 comparison parameter is selected as free parameter 1
P16.06	Comparator 2 configuration	1	Select Comparator 2 configuration to select less than
P16.07	Comparator 2 delay time	10.000	Comparator 2 delay time is 10.000S
P16.36	Logic unit 1 parameter selection 1	1340	Logic unit 1 parameter selection 1 is the comparator output
P16.37	Logic unit 1 input bit selection 1	0	Logic unit 1 input bit is selected as comparator 1
P16.38	Logic unit 1 parameter selection 2	1341	Logic unit 1 parameter selection 2 is the comparator output
P16.39	Logic unit 1 input bit selection 2	0	Logic unit 1 input bit selection 2 is comparator 2
P16.42	Logical unit 1 configuration 1	1	Logical unit 1 is configured with
P1.30	Virtual terminal setting	1350	Virtual terminal setting selection logic output 1
P3.08	Source of fault command	17	The fault command comes from the virtual terminal setting bit0

Signal loss macro

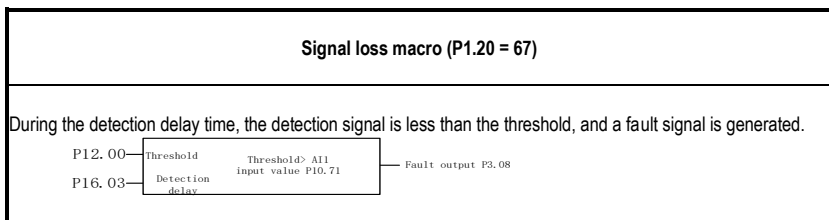

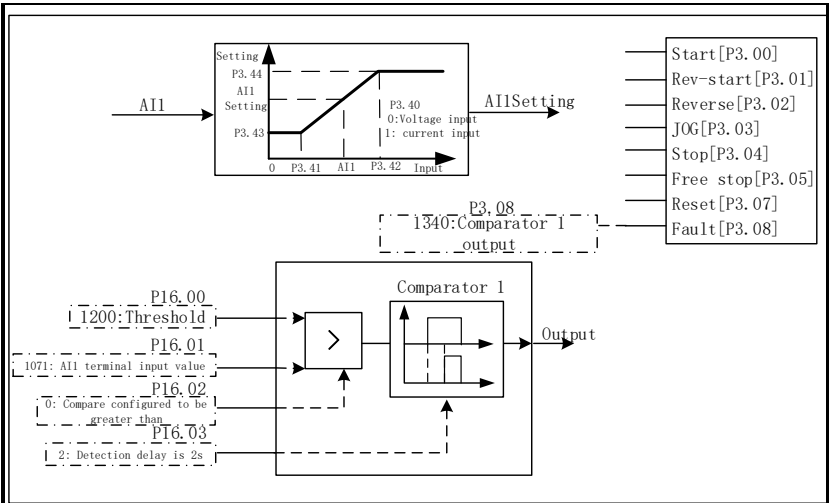

Parameter No.	Function	Setting value	Note
P12.00	Free parameter 1	1	The threshold is set to 0.1V (10V corresponds to 100%)
P16.03	Comparator 1 delay time	2	Comparator 1 delay time is selected as 2s
P16.00	Comparator 1 input parameter selection	1200	The input parameter of comparator 1 is selected as the lost voltage
P16.01	Comparator 1 comparison parameter selection	1071	Comparator 1 comparison parameter selection is A11 terminal input value
P16.02	Comparator 1 configuration	0	Select Comparator 1 configuration to choose greater than
P1.30	Virtual terminal setting	1340	Logic unit 1 parameter selection 1 is the comparator output
P3.08	Source of fault command	17	The fault command comes from the virtual terminal setting Bit0

Internal control eight-stage speed macro

Internal control eight-stage speed macro (P1.20 = 68)

- The internal control eight-stage timing switching speed.
- The external terminal uses S4 as the start signal.
- Cyclic execution.

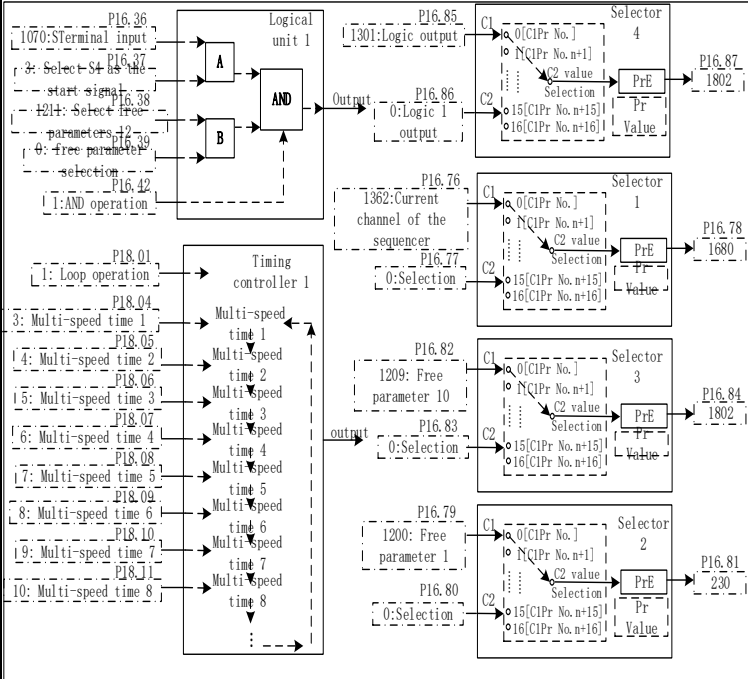
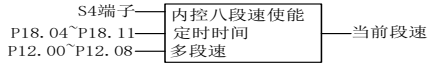

Parameter No.	Function	Setting value	Note
P12.00	Free parameter 1	0	Stop frequency is set to 0HZ
P12.01	Free parameter 2	10	Multi-speed 1 is set to 5HZ
P12.02	Free parameter 3	20	Multi-speed 2 is set to 10HZ
P12.03	Free parameter 4	30	Multi-speed 3 is set to 15HZ
P12.04	Free parameter 5	40	Multi-speed 4 is set to 20HZ
P12.05	Free parameter 6	50	Multi-speed 5 is set to 25HZ
P12.06	Free parameter 7	60	Multi-speed 6 is set to 30HZ

P12.07	Free parameter 8	70	Multi-speed 7 is set to 35HZ
P12.08	Free parameter 9	80	Multi-speed 8 is set to 40HZ
P18.04	Timer 1 phase 1 time	3	Multi-speed time 1 is set to 3s
P18.05	Timer 1 phase 2 time	4	Multi-speed time 2 is set to 4s
P18.06	Timer 1 phase 3 time	5	Multi-speed time 3 is set to 5s
P18.07	Timer 1 phase 4 time	6	Multi-speed time 4 is set to 6s
P18.08	Timer 1 phase 5 time	7	Multi-speed time 5 is set to 7s
P18.09	Timer 1 phase 6 time	8	Multi-speed time 6 is set to 8s
P18.10	Timer 1 phase 7 time	9	Multi-speed time 7 is set to 9s
P18.11	Timer 1 phase 8 time	10	Multi-speed time 8 is set to 10s
P16.37	Logic unit 1 input bit selection 1	3	Select S4 as the start signal, 0 is S1, 1 is S2 ...
P18.01	Timer 1 working mode	1	The working mode starts from multi-speed 1 to multi-speed 8 and runs cyclically. If it is set to 0, it will only run once.
P18.00	Timer 1 clock source	3	Multi-speed time unit is S
P16.36	Logic unit 1 parameter selection 1	1070	S terminal input as cycle start signal
P16.38	Logic unit 1 parameter selection 2	1211	Select high level signal
P16.39	Logic unit 1 input bit selection 2	0	Select high level signal
P16.42	Logical unit 1 configuration 1	1	S terminal input high level signal is valid
P12.09	Free parameter 10	5	S terminal without input timing pause
P12.10	Free parameter 11	3	If set to 8: S terminal has no input, the current set frequency = stop frequency
P12.11	Free parameter 12	1	If set to 9: S terminal has no input, the current set frequency = multi-speed 1
P16.82	Selector 3 parameter source	1209	S terminal has input timing start
P16.83	Selector 3 settings	0	High level signal
P16.84	Selector 3 destination parameters	1802	Selector 3 parameter source is free parameter 10
P16.85	Selector 4 parameter source	1350	Selector 3 is set to 0
P16.86	Selector 4 settings	0	The destination parameter of selector 3 is the timing controller 1 control command
P16.87	Selector 4 destination parameters	1683	Selector 4 parameter source is logic output 1
P16.76	Selector 1 parameter source	1362	Selector 4 is set to 0
P16.77	Selector 1 setting	0	The purpose parameter of selector 4 is set by selector 3.

P16.78	Selector 1 destination parameters	1680	The parameter source of selector 1 is the current channel of timing controller 1.
P16.79	Selector 2 parameter source	1200	Selector 1 is set to 0
P16.80	Selector 2 settings	0	The purpose parameter of selector 1 is set by selector 2.
P16.81	Selector 2 destination parameters	230	Selector 2 parameter source is free parameter 1
P2.10	Setpoint source 1	1	Selector 2 is set to 0
P2.13	Set channel 1 relationship selection	0	The destination parameter of selector 2 is multi-speed 0
P16.88	Selector 5 parameter source	1360	Set value source 1 is multi-speed
P16.89	Selector 5 settings	0	Set channel 1 relationship to F1
P16.90	Selector 5 destination parameters	1290	Timer count
P12.95	Free parameters 96	1803	Selector 5 is set to 0
			Save timer count when power off
P16.43	Logical unit 1 configuration 2	0	Eight-speed memory, the value of P12.90 at power-on is given to the parameter number set in P12.95
P18.03	Timer 1 set value	0	
P18.12	Timer 1 phase 9 time	0	Unused
P18.13	Timer 1 phase 10 time	0	No multi-speed jump
P18.14	Timer 1 phase 11 time	0	Multi-speed time 9 is set to 0s
P18.15	Timer 1 phase 12 time	0	Multi-speed time 10 is set to 0s
P18.16	Timer 1 phase 13 time	0	Multi-speed time 11 is set to 0s
P18.17	Timer 1 phase 14 time	0	Multi-step speed time 12 is set to 0s
P18.18	Timer 1 phase 15 time	0	Multi-step speed time 13 is set to 0s
P18.19	Timer 1 phase 16 time	0	Multi-step speed time 14 is set to 0s

Chapter 8 RS485 Communication

9.1 Introduction

The inverter can be controlled and monitored by PLC or host computer software via RS-485.

9.2 Specifications

Table 9-1

project	Instruction
way of communication	RS485
Transmission type	Single master and multiple slaves
Number of connections	Max 31
Transmission distance	Maximum 1200m (recommended within 700m)

Table 9-2

project	Instruction
Communication speed	2400, 4800, 9600, 19200, 38400 bps
Control sequence	Asynchronous communication
Communication Systems	Half duplex
Stop bit length	0, 1, 1.5, 2 bit
Data bit	8, 9 bit
Parity check	No check, even check, odd check

9.3 Communication protocol

The complete Modbus query message includes: device address, function code, sent data, and error detection field. At the same time, the message returned by the device also includes the device address, function code, any data that needs to be returned, and the error detection field. If an error occurs during message reception, or the slave device cannot execute its command, the slave device will create an error message and send a response.

Format description

Table 9-3 Communication format

Address	Function code	Data code	CRC check
8bits	8bits	N*8bits	16bits

- 1) Address: 1-247 (namely the address of the slave connected to a PC);
- 2) Function code: supported functions (see Table 9-4);
- 3) Data code: data content $N \times 8$ bits;

4) CRC check: CRC check value;

Table9-4 Functional coding

Function code	Instruction
0x03	Read holding register
0x06	Preset single register (16-bit mode)
0x10	Preset multiple registers (32-bit mode)

Address coding

In order to be compatible with different host computers, 16-bit and 32-bit access methods can be used for the same parameter. The corresponding addresses are shown in the table below. When using the 16-bit method, please note that the parameter value must be within the 16-bit expression range.表 9-5 Address coding rules

Parameter value	Address	RAM address
16 位	Parameter number - 1	Parameter number - 1 + 32768
32bit	Parameter number - 1 + 16384	Parameter number - 1 + 16384 + 32768

Note: When writing by address, the parameter value will be stored in the inverter EEPROM. Frequent storage of EEPROM will reduce the service life of EEPROM, so when there is no need to store, just change the value in RAM, then use the RAM address to write the parameters.

Table 9-6 Common Address Table

Set the frequency (write only), see the parameters P2.10 ~ P2.14 to enable the communication settings

Function	Parameter number	16-bit mode	32-bit mode	note
Communication setting	P2.90	EEPROM:0121H RAM: 8121H	EEPROM: 4121H RAM:C121H	P1.47 = 0, upper computer 0 ~ 100000 corresponds to 0 ~ maximum frequency P2.18; P1.47 = 1, upper computer 0 ~ 10000 corresponds to 0 ~ maximum frequency P2.18; P1.47 = 2, upper computer 0 ~ 1000 corresponds to 0 ~ maximum frequency P2.18; P1.47 = 3, upper computer 0 ~ 100 corresponds to 0 ~ maximum frequency P2.18;

Control commands (write only), see the parameters P3.00 ~ P3.09 to enable the corresponding communication commands

Function	Parameter number	16-bit mode	32-bit mode	Command word (Bit)	note
Communication commands	P2.91	EEPROM:0122H RAM:8122H	EEPROM:4122H RAM:C122H	0	start up
				1	Reverse
				2	Start reverse

				3	JOG
				4	stop
				5	Emergency stop
				6	Safe stop
				7	Reset
				9	Parameter self-learning
				11	time out
				13	UP (incremental)
				14	DOWN (decreasing)

Inverter status (read only)

Function	Parameter number	16-bit mode	32-bit mode	Command word (Bit)	note
Current status	P10.15	03F6H	43F6H	0	Powering off
				1	Stopping
				2	running
				3	Start function start
				4	Parameter self-study
				5	Operating
				6	Ready
				10	malfunction
				11	Call the police
				12	STO status

Inverter failure (read only)

Function	Parameter number	16-bit mode	32-bit mode	Command word (Bit)	note
Fault status	P10.16	03F7H	43F7H	1	System abnormality
				4	Ground fault
				5	Short circuit to ground
				6	Output short circuit
				7	Output overcurrent
				8	DC bus overvoltage
				9	DC bus undervoltage
				10	Inverter overheating
				13	Rectifier bridge overheating
				14	U phase missing phase
				15	Phase V missing phase
				16	W phase missing phase
				19	No motor connection
				20	Input phase loss
				21	Inverter overload
				22	Overtorque
				24	Motor overheating
25	Motor overload				
				26	Current limit

				27	Input power down
--	--	--	--	----	------------------

Inverter data (read only)

Function	Parameter number	16-bit mode	32-bit mode	Data range	Unit
Output frequency	P10.21	03FCH	43FCH	-65535.0~65535.0	Hz
Output current	P10.22	03FDH	43FDH	0.00~65535.00	A
The output voltage	P10.23	03FEH	43FEH	0.0~65535.0	V
Output torque	P10.24	03FFH	43FFH	0.000~65535.000	NM
DC voltage	P10.25	0400H	4400H	0.0~65535.0	V
Inverter temperature	P10.26	0401H	4401H	0~65535	°C
power	P10.30	0405H	4405H	0.000~65535.000	kw
power consumption	P10.31	0406H	4406H	0.000~4294967.295	Kw*h
Operating hours	P10.40	040FH	440FH	0~4294967295(16 Hex)	h
Number of power-on	P10.41	041FH	441FH	0~4294967295(16 Hex)	
S terminal input status	P10.70	042DH	442DH	0~4294967295(16 Hex)	
A1 terminal input value	P10.71	042EH	442EH	-65535.000~65535.000	%
A2 terminal input value	P10.72	042FH	442FH	-65535.000~65535.000	%
Y terminal output status	P10.74	0431H	4431H	0~4294967295(16 Hex)	
AO1 terminal output value	P10.75	0432H	4432H	-65535.000~65535.000	%
AO2 terminal output value	P10.76	0433H	4433H	-65535.000~65535.000	%

9.4 Read holding register

Read the data in the holding register, taking parameter P10.16 fault status and parameter P2.30 multi-stage speed 0 as an example.

Fault state (example)

Read the value of inverter parameter P10.16, it can be known from the fault status table, just read 16 bits, then the register address = 1016-1 = 1015 (03F7H).

Send data: 01 03 03 F7 00 01 35 BC

Receive data: 01 03 02 00 0A 38 43

P10.15 = 10 (000AH). The fault state is that the inverter is overheated. (See fault code)

Send data

Slave address	01H
function code	03H
Register address	03H (high byte)
	F7H (low byte)
data	00H (high byte)
	01H (low byte)
CRC check	35H (low byte)
	BCH (high byte)

Receive data

Slave address	01H
function code	03H
Number of data (Calculated in Byte)	02H
data	00H (high byte)
	0AH (low byte)
CRC check	38H (low byte)
	43H (high byte)

Multi-speed 0 (example)

Read the value of inverter parameter P2.30, when accessed with 32 bits, the register address = 230-1 + 16384 = 16613 (40E5H).

Send data: 01 03 40 E5 00 02 C0 3C

Receive data: 01 03 04 00 00 88 B8 9C 41

The read data is 35000 (88B8H), which shows that P2.30 = 35.000

Send data

Slave address	01H
function code	03H
Number of data (Calculated in Byte)	40H (high byte)
	E5H (low byte)
data	00H (high byte)
	02H (low byte)
CRC check	C0H (low byte)
	3CH (high byte)

Receive data

Slave address	01H
function code	03H
Number of data (Calculated in Byte)	04H
data (High byte)	00H (high byte)
	00H (low byte)
data (Low byte)	88H (high byte)
	B8H (low byte)
CRC check	9CH (low byte)
	41H (high byte)

Preset a single register

Write the value of inverter parameter P5.00, when accessed with 16 bits, the register address = 500-1 = 499 (01F3H).

Send data: 01 06 01 F3 00 01 B9 C5

Receive data: 01 06 01 F3 00 01 B9 C5

Send data

Slave address	01H
----------------------	-----

function code	06H
Number of data (Calculated in Byte)	01H (high byte)
	F3H (low byte)
data	00H (high byte)
	01H (low byte)
CRC check	B9H (low byte)
	C5H (high byte)

Receive data

Slave address	01H
function code	06H
Register address	01H (high byte)
	F3H (low byte)
data	00H (high byte)
	01H (low byte)
CRC check	B9H (low byte)
	C5H (high byte)

Preset multiple registers

Write the value of parameter P2.91, when accessed with 32 bits, the register address = 291-1 + 16384 = 16674 (4122H) Table 9-7 Command control word table

Parameter value (Bit)	Control word
0	start up
1	Reverse
2	Start reverse
3	JOG
4	stop
5	Emergency stop
6	Safe stop
7	Reset
9	Parameter self-learning
10	Jump
11	time out
13	UP (incremental)
14	DOWN (decreasing)

Taking the stop control word as an example, the value of parameter 2.91 is set to 16.

Send data: 01 10 41 22 00 02 04 00 00 00 10 4D F1

Receive data: 01 10 41 22 00 02 F5 FE (hexadecimal)

Send data

Slave address	01H
function code	10H

Register address	41H (high byte)
	22H (low byte)
Number of registers (16 bits)	00H (high byte)
	02H (low byte)
Number of data (Calculated in Byte)	04H
data (High byte)	00H (high byte)
	00H (low byte)
data (Low byte)	00H (high byte)
	10H (low byte)
CRC check	4DH (low byte)
	F1H (high byte)

Receive data

Slave address	01H
function code	10H
Register address	41H (high byte)
	22H (low byte)
Number of registers (16 bits)	00H (high byte)
	02H (low byte)
CRC check	F5H (low byte)
	FEH (high byte)

Communication error codes

The inverter returns data when a communication error occurs. The format is shown in Table 9-8. Communication error function code = request function code + 128.

Table 9-8 Communication error data format

Address	Function code	Fault code	CRC
8bits	8bits	8bits	16bits

Table 9-9 Error function code description

error code	Explanation
0x00	Parameter does not exist
0x01	Cannot write defined parameters
0x02	The value of the parameter exceeds the upper limit of the parameter
0x07	Unchangeable
0x0B	Not allowed to write
0x11	The data of the defined parameters cannot be changed in the current mode of the inverter
0x12	Other errors
0x40	Invalid data address
0x41	Invalid length
0x42	Invalid data length and value
0x43	Invalid parameter
0x82	No bus connection for defined parameters
0x83	The factory set value has been selected data and cannot be changed

Chapter 9 Fault Resolution and repair

9.1 Protection function



Warning

The inverter must be rectified before the fault is reset, otherwise it may result in reduced product life and damage to other equipment.

9.2 Fault code table

Fault code	Protective function	Explanation
1	System abnormality	Inverter hardware failure or software failure.
4	Ground fault	The resistance value to the ground is abnormal and leakage occurs.
5	Short circuit to ground	Short circuit to ground.
6	Output short circuit	When the output current of the inverter is greater than 250% of the rated current of the inverter, the inverter turns off the output.
7	Output overcurrent	When the output current of the inverter is greater than 200% of the rated current of the inverter, the inverter turns off the output.
8	DC bus overvoltage	If the DC voltage of the main circuit is higher than 400V (220V model) or 800V (380V model) when the motor decelerates, the inverter shuts off the output.
9	DC bus undervoltage	When the input voltage decreases, if the DC voltage of the main circuit is too low, the inverter will turn off the output.
10	Inverter overheating	When the temperature of the heat sink is detected to be overheated, the inverter turns off the output.
11	Self-learning failure	The self-learning parameters are incorrect or the motor is abnormal.
13	Rectifier bridge overheating	The rectifier module is overheated.
14	U phase missing phase	Output U phase loss.
15	V phase missing phase	Output V phase loss.

16	W phase missing phase	Output W phase loss.
19	No motor connection	The motor is disconnected during operation.
20	Input phase loss	Input power phase loss
21	Inverter overload	When the output current of the inverter exceeds the rated rating of the inverter (150% for 1 minute), the inverter turns off the output.
22	Overtorque	Motor over torque.
24	Motor overheating	The motor temperature is too high.
25	Motor overload	When the output current of the inverter exceeds the rated rating of the motor (150% for 1 minute), the inverter turns off the output.
26	Current limit	The output current exceeds the set limit threshold.
27	Input power down	The input voltage is lower than the power-down level (P5.86).
63	User failure	User-defined fault (see parameter P3.08)

9.3 Maintenance and inspection prevention

	Warning
---	----------------

Make sure to remove input power during maintenance.

Make sure that the DC connection capacitor is discharged for maintenance, even if the bus capacitance of the inverter's main circuit is still charged after the power is turned off. Use the detector to check the voltage between P + and P- before proceeding.

H1 series inverters have ESD (electrostatic discharge) sensitive components. During inspection or installation, take protective measures to avoid ESD before touching, do not change any internal parts and connections, and do not change the inverter.

9.4 Checkpoint

■ Daily inspection

- Appropriate installation environment
- Cooling system failure
- Uncommon shock and noise
- Uncommon overheating and discoloration

■ Periodic inspection

- Screws and nuts may be loose due to vibration, temperature changes, etc.
- Check that they are fastened and as tight as possible
- Foreign objects in the cooling system
- Use air to clean
- Check the cooling fan rotation conditions, capacitor conditions and magnetic contactor connection
- If not replaced normally

9.5 Parts replacement

The inverter consists of electronic components such as semiconductor devices. Due to structural or physical characteristics, the following components may age, causing the inverter to fail to operate. The components must be replaced periodically.

Chapter 10 Technical Notes

project		project description
Output	Rated voltage;	Three phase, 380~440V, 50Hz/60Hz Single phase, 200V~240V, 50Hz/60Hz
	frequency	Three phase:320V~460V;Single phase: 180V ~ 260V; Voltage imbalance rate: <3%; frequency: ± 5%
Input	Allowable voltage working range	0~Rated input voltage
	Voltage	0Hz~200Hz
	frequency	150% rated current for 1 minute, 180% rated current for 2 seconds
Main control performance	Overload capacity	V/F 、 Speed sensorless vector control
	control method	Space vector PWM modulation
	Modulation	Asynchronous motor, synchronous motor, single-phase motor (please consult the manufacturer when using)
	Motor type	150% rated torque at 0.5Hz
	Starting torque	1:100(Without speed sensor)
	Speed range	Digital setting: maximum frequency ± 0.01%; Analog setting: maximum frequency ± 1%
	Frequency accuracy	Digital setting: 0.01Hz; Analog setting: maximum frequency 1%
	Frequency resolution	Straight line / S curve acceleration / deceleration
	Acceleration and deceleration curve	Automatically limit the current during operation to prevent frequent overcurrent fault tripping
	Limiting	Support instantaneous stop and automatic frequency reduction
Run function	Instantaneous power failure	Keyboard given, terminal given, communication given
	Command source	Digital setting, analog setting, multi-speed, communication setting
	Source of settings	Support main given + PID
Operation keyboard	PID	Display output frequency, output current, output voltage, bus voltage, display value 1, display value 2, current alarm, current fault
	Nixie tube display	support
Protective function		Overcurrent protection, overvoltage protection, undervoltage protection, overheat protection, overload protection, phase loss protection, earth leakage, etc.
Environment	Place of use	Indoor, no direct sunlight, no dust, corrosive gas, flammable gas, oil mist, water vapor, dripping water or salt etc.
	Altitude	For derating above 1000 meters, derate 10% for every 1000 meters
	Ambient temperature	- 10 °C ~ + 40 °C(Ambient temperature is 40 °C~ 50 °C(please use derating)
	humidity	5% ~ 95% RH, no condensation
	storage temperature	- 40°C + 70°C
	vibration	Less than 5.9 m / s 2 (0.6g)

Chapter 11 Selection of braking resistor

11.1 Brake resistor configuration table

Voltage level	Inverter power	Braking unit	Braking resistor			Braking torque (< 10%UD)
			Power (W) / resistance (Ω)		amount	
220V	0.75KW	Built-in	80	120	1	100%
	1.5KW		150	100	1	
	2.2KW		300	68	1	
	3.7KW		300	68	1	
	5.5KW		400	30	1	
	7.5KW		400	30	1	
380V	0.75KW		150	300	1	
	1.5KW		200	300	1	
	2.2KW		200	200	1	
	4.0KW		400	150	1	
	5.5KW		400	100	1	
	7.5KW		750	75	1	
	11KW		1000	60	1	
	15KW		1500	40	1	
	18.5KW	2500	30	1		
	22KW	3000	30	1		

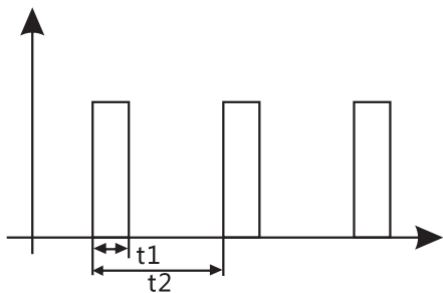

Precautions:

1. Please select the power number and resistance value recommended by our company

2. The power numbers and electric group values recommended in the above table are calculated according to 100% braking torque and 10% utilization rate. When the load demand and system reliability are met, the resistance power and resistance value can be appropriately increased or decreased; When it is required to increase the braking torque or use a higher power, the power and resistance value of the braking resistor should be changed appropriately, or consult our company.

3. When installing the braking resistor, be sure to consider the safety and non-flammability of the surrounding environment.

4. Braking frequency $UD = t1 / t2 * 100\%$

t1: braking time within one working cycle

t2 one duty cycle

The braking usage rate doubles and the power of the corresponding braking unit and braking resistor is doubled.

1. In the above table, the resistance value and power greater than 2500W are the total resistance value and power, the power of the resistance

Based on 2500W as the base number, for example, if you need a 2500W 6Ω resistor, you need 10 250W 60Ω resistors in parallel.

Calculation of braking resistor

Statistics show that when the braking current IB flowing through the energy-consuming circuit is equal to half of the rated current of the motor, the braking torque of the motor is approximately equal to its rated torque:

$$IB = IMN / 2 \quad TB \approx TMN \quad \text{or} \quad IB = 2UB / IMN$$

In the formula:

IB—braking current, A; IMN—motor rated current, A; TB—braking torque, N.m; TMN—motor rated torque, N.m.

In general, the selection range of braking torque is:

$$TMN < TB < 2TMN \quad \text{then:} \quad IMN < IB < 2IMN$$

The user can decide the braking current according to the specific situation of the production machinery.

After the braking current is determined, it is easy to calculate the braking resistance:

$$RB = UB / IB \quad RB_{min} = UB / IMN$$

UB is the braking threshold voltage; RB is the resistance of the braking resistor, where UB is generally 1.1 times the rated bus voltage; Rbmin is the minimum value of the braking resistor

Common values of braking threshold voltage:

AC220V: DC380V AC380V: DC680V AC660V: DC1140V

Knowing IB and RB can determine the power of the resistor

λ : Actual resistance value / calculated value first; ED%: braking utilization rate

for example:

Suppose an existing 7.5KW motor has a rated current of 18A and a rated input voltage of 380V

Then there are: $RB = 680V / 9A = 75 \text{ Euro}$

$$RB_{min} = 680/18 = 38 \text{ Euro}$$

75 Euros according to experience

Power of braking resistor = $1 * 680^2/75 * 0.1 = 616W$

In actual use, the power can be properly amplified.

11.2 Installation dimension drawing of braking resistor

rated power (W)	Size (mm)									
	L1(± 2)	L2(± 5)	L3(± 3)	D(±2)	B	B1	H	H1(± 3)	N	φd
80	152	174	196	28	6.5	28	28	61	10	4.5
150	195	217	239	40	8	40	41	81	12	5.5
200	195	217	239	40	8	40	41	81	12	5.5
300	282	304	326	40	8	40	41	81	12	5.5
400	282	304	326	40	8	40	41	81	12	5.5
750	316	338	360	50	8	50	45	101	16	6
1000	300	325	350	60	8.5	60	60	119	16	6

1500	415	440	465	60	8.5	60	60	119	16	6
2000	510	535	560	60	8.5	60	60	119	16	6
2500	600	625	650	60	8.5	60	60	119	16	6

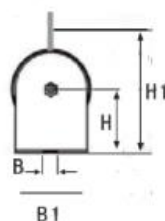
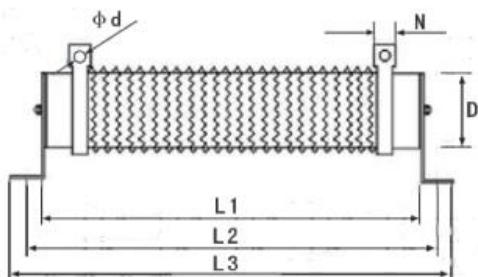

Chapter 12 Dimensions

H1Series structure size table						
Frame number	Size (mm)					
	W(width)	H (high)	D (deep)	A	B	d
F1	85	170	124	67.3	158	5
F2	97	194	133	85	184	5
F3	126	237	147	112	223	5
F4	168	298	160	154	283	6
F5	198	355	177	183	338	6

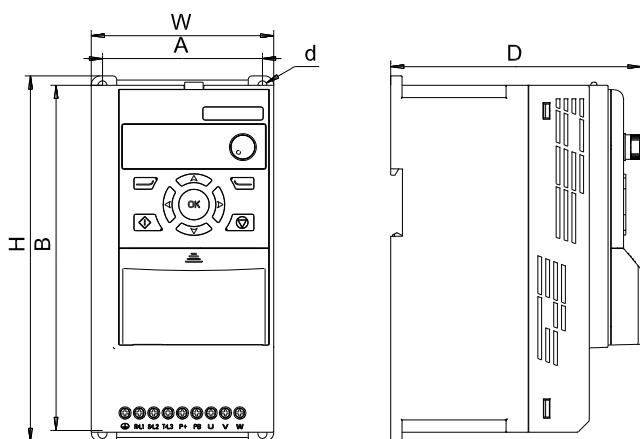

Chapter 13 Quick parameter configuration table

Quick parameters	Basic parameters	Function
P0.09	P1.11	Parameter operation
P0.10	P2.10	Setting (frequency) source F1
P0.11	P2.11	Setting (frequency) source F2
P0.12	P2.13	Set relationship selection
P0.13	P2.18	Maximum setting
P0.14	P5.08	Motor output frequency upper limit
P0.15	P2.00	Multi-speed source
P0.16	P2.30	Multi-speed 0
P0.17	P2.31	Multi-speed 1
P0.18	P2.32	Multi-speed 2
P0.19	P2.33	Multi-speed 3
P0.20	P2.34	Multi-speed 4
P0.21	P2.35	Multi-speed 5
P0.22	P2.36	Multi-speed 6
P0.23	P2.37	Multi-speed 7
P0.24	P2.50	Acceleration time 0
P0.25	P2.70	Deceleration time 0
P0.26	P2.24	Jog frequency
P0.30	P3.00	Start command source

P0.31	P3.01	Reverse start command source
P0.32	P3.02	Reverse command source
P0.33	P3.03	Jog command source
P0.34	P3.04	Source of stop command
P0.35	P3.05	Free parking order source
P0.36	P3.07	Reset command source
P0.37	P3.20	S1 type
P0.38	P3.21	S2 type
P0.39	P3.22	S3 type
P0.40	P3.30	Y1 terminal source
P0.41	P3.41	AI1 low-end voltage (current)
P0.42	P3.42	AI1 high-end voltage (current)
P0.43	P3.43	AI1 low-end settings
P0.44	P3.44	AI1 high-end settings
P0.45	P3.61	AO1 signal source
P0.46	P3.62	AO1 low-end settings
P0.47	P3.63	AO1 high-end settings
P0.48	P3.64	AO1 low-end voltage (current)
P0.49	P3.65	AO1 high-end voltage (current)
P0.50	P4.00	PID proportional gain
P0.51	P4.01	PID integral gain
P0.52	P4.05	PID output upper limit
P0.53	P4.06	PID output lower limit
P0.54	P4.09	PID range
P0.55	P4.11	PID sleep frequency
P0.56	P4.12	PID enters sleep time
P0.57	P4.13	PID wakeup deviation
P0.58	P4.14	PID entry wake-up time
P0.59	P4.15	PID sleep action
P0.60	P5.10	Start function
P0.61	P5.11	Start Time
P0.62	P5.12	Start frequency
P0.63	P5.19	DC injection current
P0.64	P5.20	Stop function
P0.65	P5.21	Stop frequency
P0.66	P5.22	DC braking current
P0.67	P5.23	DC braking time
P0.68	P5.30	Brake resistance mode
P0.70	P5.00	control method
P0.71	P6.05	Carrier frequency
P0.72	P6.11	Motor Power
P0.73	P6.12	Motor voltage
P0.74	P6.13	Motor frequency
P0.75	P6.14	Motor current
P0.76	P6.15	Motor speed
P0.78	P7.71	VF curve-F1

P0.79	P7.72	VF curve-F2
P0.80	P7.73	VF curve-F3
P0.81	P7.74	VF curve-F4
P0.82	P7.75	VF curve-V0
P0.83	P7.76	VF curve-V1
P0.84	P7.77	VF curve-V2
P0.85	P7.78	VF curve-V3
P0.86	P7.79	VF curve-V4

Note: The parameter table in the H1 series inverter simple manual is a shortcut parameter, please refer to the above table for the mapping to the basic parameters. After the data of the shortcut parameter is changed, the corresponding basic parameter will also be changed; after the data of the basic parameter is changed, the corresponding shortcut parameter will also be changed.

Chapter 14 Standard card (H10001) instructions for use

15.1 Overview

The H10001 card is a multi-functional I / O standard card for use with H1 series inverters. It can realize 4 digital inputs, 1 relay output and 1 analog input. It also has an RS-485 communication interface (integrated in Ethernet port), can be connected to the external keyboard.

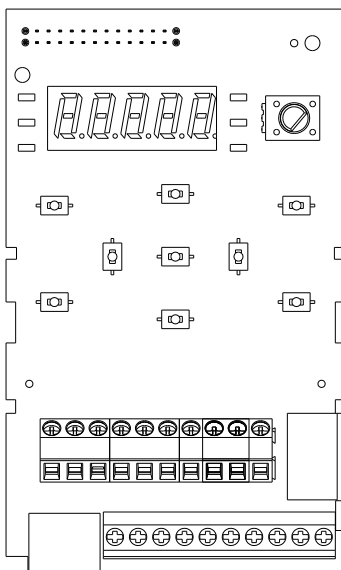

Schematic diagram of standard card distribution

Mechanical installation

Please install it when the inverter is completely powered off; align the pins (26 pins) on the function card and the inverter power board and insert tightly.

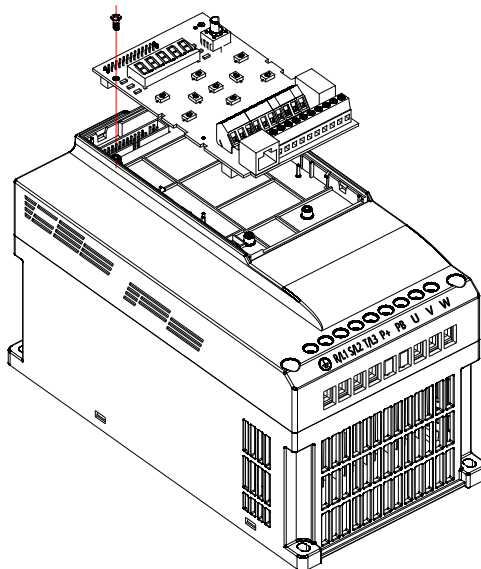

Function card mechanical installation drawing

15.2 Wiring diagram

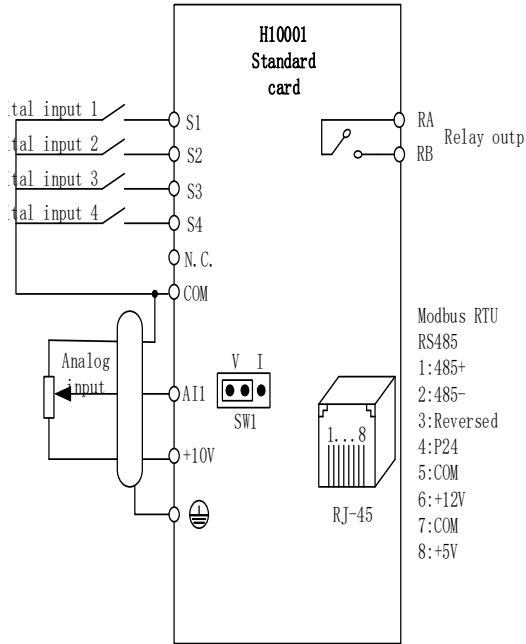

15.3 Control terminal

Terminal specifications

Terminal symbol	Terminal name	Function Description
+10V	10V power supply	Provide + 10V power to the outside, maximum output current 50mA
AI1	Analog input terminal	1. Input voltage range: DC 0V ~ 10V 2. Input current range: 0 ~ 20mA 1、 Select voltage or current through SW1 jumper
COM	Digital, analog	Internally isolated from communication ground GND
S1~S4	Digital input terminal	1. Optocoupler isolation 2. Input impedance: 2.4kΩ

		3. Voltage range during level input, 9V ~ 30V
N.C.	Set aside	Reserved terminal
RA RB	Relay output	1、Resistive load: 250VAC 3A / 30VDC 3A; 2、Inductive load: 250VAC 0.2A / 24VDC 0.1A (cosØ = 0.4)
RJ45	Network port	The keyboard can be externally connected or connected to the host computer

Terminal wiring

A. Digital input terminal:

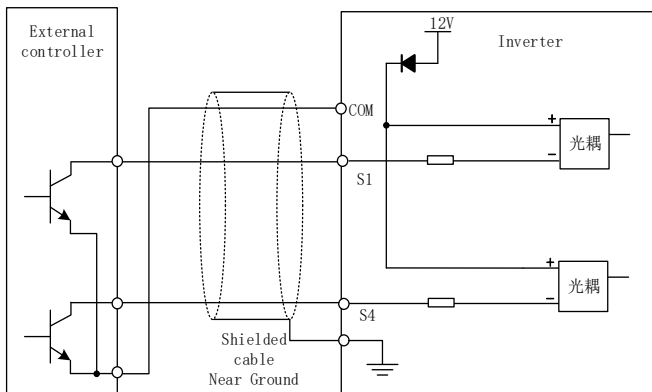

Digital input terminal wiring

Note: The wiring method of the digital input terminal of the standard configuration card is NPN type. If the user needs other wiring methods, please consult our technical staff.

B. Analog input terminal:

Because weak analog voltage signals are particularly susceptible to external interference, shielded cables are generally required, and the wiring distance should be as short as possible, not exceeding 20 meters. As shown below:

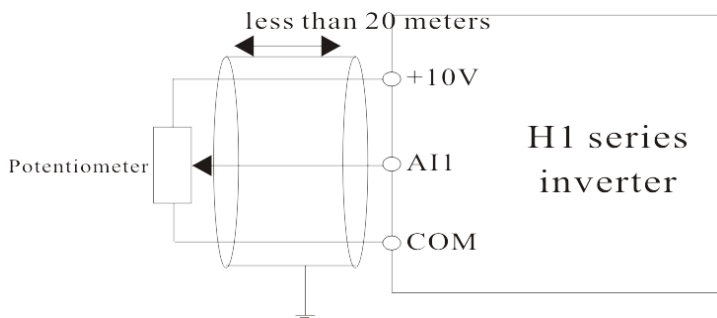

Schematic diagram of analog input terminal wiring

In some occasions where the analog signal is severely interfered, the analog signal source needs to add a filter capacitor or a ferrite core. As shown below:

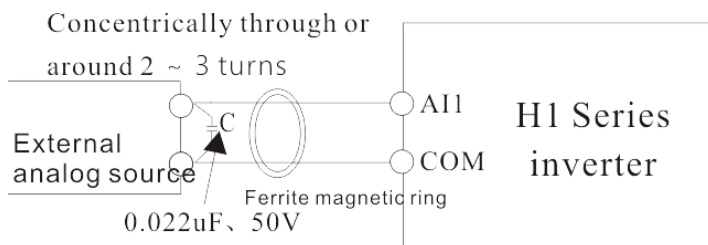

Wiring diagram of analog input terminal plus filter processing

