

Rotary Encoder

HE series

INSTRUCTION MANUAL

Thank you for purchasing HANYOUNG product.
Please check whether the product is the exactly same as you ordered. Before using the product, please read this instruction manual carefully.

MAIN PRODUCTS

- DIGITAL : Temperature Controller, Counter, Timer, Speedmeter, Tachometer, Panel Meter, Recorder
- SENSOR : Proximity Sensor/Photo Electric Sensor, Rotary Encoder, Optical Fiber Sensor, Pressure Sensor
- ANALOG : Timer, Temperature Controller

HEAD OFFICE

1381-3, Juan-Dong, Nam-Gu Incheon, Korea
TEL: (82-32)876-4697 FAX: (82-32)876-4696

HANYOUNG NUX



Safety information

CAUTION

1. Before using the product you purchased, make sure that it is exactly what you ordered.
2. Make sure that there is no damage or abnormality of the product during the delivery.
3. The transmitter for measuring the length is composed of precision parts, so can easily be damaged with external impact, therefore handle with care.
4. The shield wire of the transmitter for length measurement is not connected to the case.
5. When the product gets wet, the inspection is essential because there is danger of an electric leakage or fire.
6. For the continuous and safe use of this product, the periodical maintenance is recommended.
7. If you use the product with methods other than specified by the manufacturer, there may be bodily injuries or property damages.

On Mega Test

An internal pressure of 500V DC exists between the Case and the electric circuit, however, there are dangers of damage the electrical circuit if voltage is applied accidentally, so do not perform mega tests.

On Installation

1. During installation, do not apply impact on or twist the shaft of the transmitter for length measurement.
2. During installation, do not apply excessive force when combining the shaft of transmitter for length measurement and the instrument.
3. During installation, take caution because the life span of the transmitter for length measurement is dependent on the usage condition and the environment.
4. Do not decompose, modify, revise or repair this product. This may be a cause of malfunction, electric shock or fire.
5. Reassemble this product while the power is OFF. Otherwise, it may be a cause of malfunction or electric shock.

About Wiring

1. Separate an input signal cable from an output signal cable. If separating is not possible, please use the input signal cable after shielding it.
2. If there is excessive noise from the power supply, using insulating transformer and noise filter is recommended.
3. Do not connect anything to the unused terminals.
4. After checking the polarity of terminal, connect wires at the correct position.
5. As for wiring, ensure they are as short as possible.
6. Having the same pipe for wiring of the transmitter for length measurement with the power line or an identical connection could cause malfunction, therefore please take caution.
7. Wrong connection of the wiring of transmitter for length measurement may damage the internal circuit. Please take sufficient caution.

About vibration

1. If intense vibration or impact is applied on the transmitter for length measurement, the wrong pulse is generated causing malfunction, therefore, absolute care is necessary when selecting the installation and disposition location.
2. As much as the amount of pulse per cycle, the slit gap of rotation slit is narrower, therefore can be easily affected by vibration, and the vibration applied during slow rotation or when stationary, may get transmitted to the shaft or the main body, causing wrong pulse generation, therefore, please take caution. The vibration applied to the transmitter for length measurement can become a cause for wrong pulse generation, so please take caution in terms of installation location or location for attachment.

For noise prevention

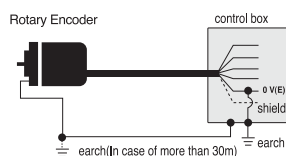

Distance from control box	Wiring of Rotary Encoder
30 m Max.	As for Rotary Encoder Case, connect on the control board case by 3~5.5MM electric wire. For the 0 V terminal, connect on the control board case with identical type of electrical wire and earth it.
30 m Min.	Perform as indicated above, and earth the Rotary Encoder.

* The caution on the safety stated above, must be kept, otherwise malfunction can be induced.

Ratings

Mode	Shaft external diameter	Pulse number per revolution	Phase type	Output type	Power voltage	Wire Specification
HE40B	6: \varnothing 6 mm 8: \varnothing 8 mm (Option)	* 1, 10, 50, 60, 100, 120,200,250,300,360 ,400,500,512,600,80 0,1000,1024,2000,20 48,3000,3600,5000	2: A,B 3: A, B, Z 3C: A, B, /Z 4: A, /A, B, /B 6: A, /A, B, /B Z, /Z (Standard: A, B, Z)	O: NPN Open collector N: NPN Voltage T: Totem- pole L: Line driver (Line Drive: 5V d.c)	5: 5V dc 12: 12V d.c (5-12V d.c) 24: 24V d.c (12-24V d.c)	No mark: Standard type C: Connector
HE50B	8: \varnothing 8 mm	* 1, 10, 50, 60, 100, 120,200,250,300,360 ,400,500,512,600,80 0,1000,1024,2000,20 48,3000,3600,5000				

* " " mark : Only A, B phase can output (Line Drive output is A, /A, B, /B)
* The item that is not in the above revolution is order made product

Specification

Mode #	HE□□B	HE□□B	HE□□B	HE□□B
Output type	NPN Voltage output	NPN Open collector output	Totem Pole Output	Line Driver Output
Output type	A, B, Z phase			A, B, Z, A, B, Z phase
Phase difference on Output	Phase difference between A, B phase: T/4 ± T/8 (Cycle of A phase = T)			
Max Response Frequency	300 kHz			
Power voltage	5 - 12 V d.c / 12 - 24 V d.c ± 5%			5 V d.c ± 5%
Current Consumption	70 mA Max. (No-load) Line Drive output below 30 mA (No-load)			
Connection method	WIRE			
Control output	Load voltage : 30 V Max. Load Current : 30 mA Max. Residual Voltage : 0.4 V Max.		For Low Load Current: 30 mA Max. Residual Voltage: 0.4 V Max. For High Load Current: 10 mA Max. Residual Voltage: Above 2.5V of rated voltage	For Low Load Current: 20 mA Max. Residual Voltage: 0.4 V Max. For High Load Current: 20 mA Max. Residual Voltage: 2.5 V Max.
Response Time	1 μ s Max. (Cable length 1.5 m / sink=30 mA)		1 μ s Max. (Cable length 1.5 m / sink=10 mA)	1 μ s Max. (Cable length 1.5 m / sink=30 mA)
Starting Torque	\varnothing 40 : 40 gf · cm (0.004 N · m Max) \varnothing 50 : 80 gf · cm (0.008 N · m Max)			
Moment of inertia	\varnothing 40 : 40 g · cm ² Max., \varnothing 50 : 80 g · cm ² Max.			
Permissible Shaft Loading	\varnothing 40 : Radial : Within 2 kgf, Thrust : Within 1 kgf \varnothing 50 : Radial : Within 2.5 kgf, Thrust : Within 1.2 kgf			
Max. Permissible Revolution	5000 rpm			
Bearing Life	1.2 x 10 ⁶ /rpm : hour			
Insulation Resistance	Over 100 M Ω (Base on 500 V d.c mega between terminal and case)			
Dielectric strength	800 V a.c (Between terminal and case at 60Hz for 1 minute)			
Vibration Resistance	10-55Hz (Cycle for 1 minute), Double amplitude width: 1.5mm, Each X · Y · Z direction for 2 hours			
Shock Resistance	\varnothing 40 : 50 G Max., \varnothing 50 : 75 G Max.			
Operating Ambient Temperature	-10 ~ 60 °C (Without condensation), Storage Temperatur : -25 ~ 85 °C			
Operating Ambient Humidity	35 ~ 85% R.H.			
Protection	Protection IP 50 (IEC Standard)			
Wire Specification	5 P, \varnothing 5.0 mm, Length : 1.5 m, Shield cable (Line Driver Type : 8P, \varnothing 5.0 mm, Length : 1.5 m, Shield cable)			
Weight	\varnothing 40 : 170 g, \varnothing 50 : 200 g			
Accessory	\varnothing 8.0 mm Coupling, Bracket (\varnothing 40mm Bracket -- Separate sales)			

Aspect Dimension

Ø50 Axis

[Unit: mm]

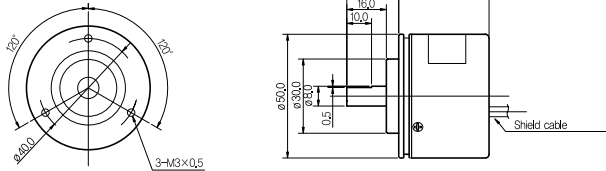

Ø40 Axis

[Unit: mm]

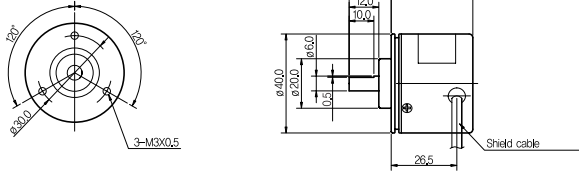

Ø50 Axis

[Unit: mm]

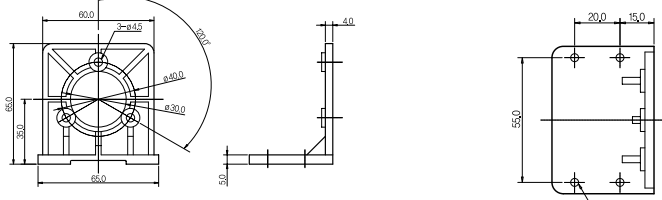

Ø40 Axis

[Unit: mm]

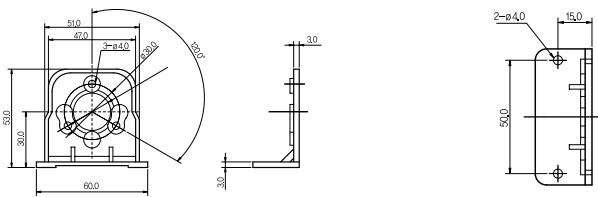

Mode #: RC-06 / RC-08 (Coupling)

[Unit: mm]

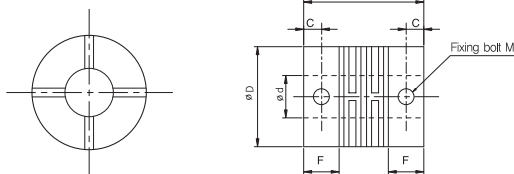

	C	D	d	F	L	M
Ø40	3.5	19	6 ^{+0.05}	7.2	25	M4 x5
Ø50	3.5	19	8 ^{+0.05}	6.0	23.2	M3 x5

※When coupling is combined in spin axis, The big combination error (Partial disposition, Declination) between spin axis and coupling may cause of shorten of life-time for encoder and coupling.

Wiring Diagram

Voltage output, Totem Pole output, Open collector output

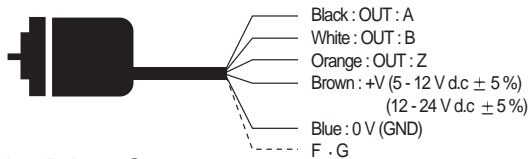

Line Driver Output

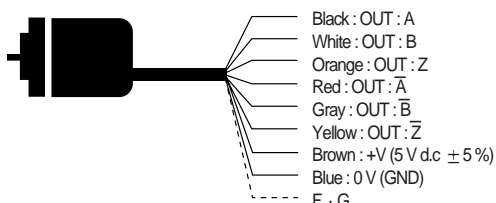

※ Please insulate unused lines

※ Metal case of encoder and Shield line must be ground connection.

Output Circuit

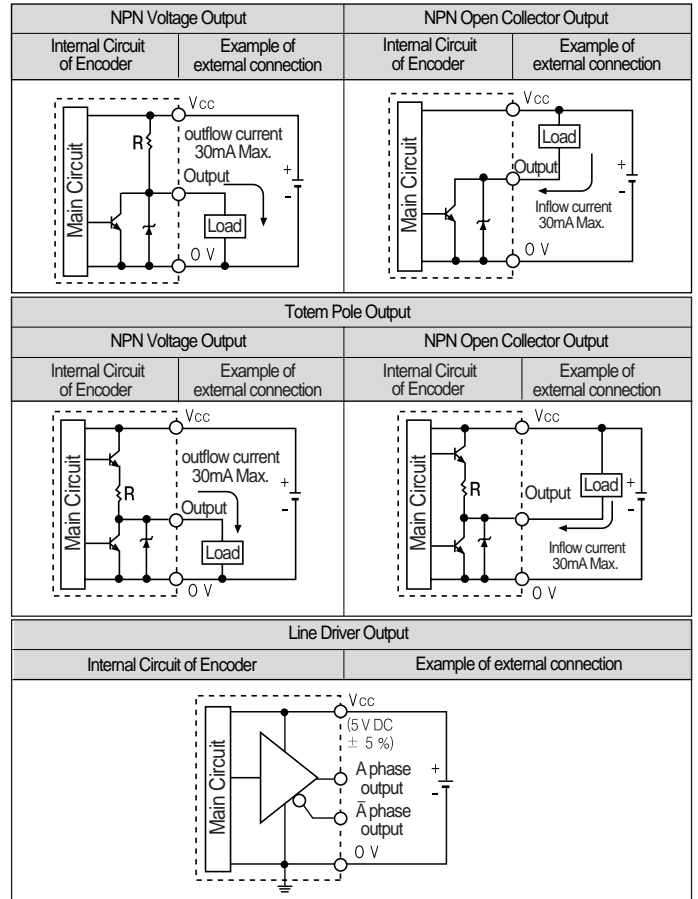

※ The output circuit of A, B, Z phase (Line drive output A, A-bar, B, B-bar, Z, Z-bar) is same.

Output wave

NPN Voltage output, NPN Open Collector Output, Totem Pole output

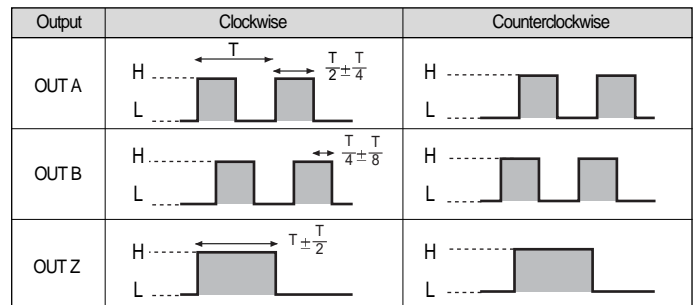

Line Driver Output

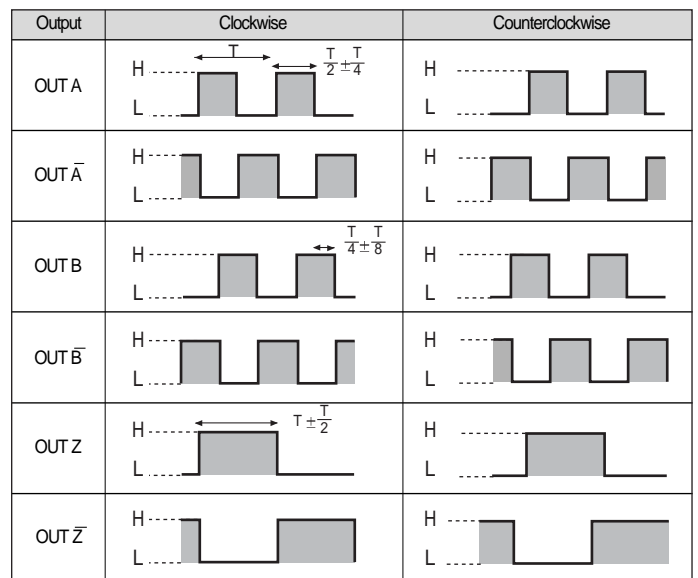

Clockwise (CW): When you are looking at the shaft of the product, it is turning in a clockwise direction.

Counterclockwise (CCW): When you are looking at the shaft of the product, it is turning in a counterclockwise.