

MANAK-LAB25

MINIATURE LINEAR DC ACTUATORS

Small motor actuator with ACME screws, built-in Micro switch and an internal diode, can automatically stop and enables the change of direction by simply reversing the applied voltage polarity. stroke length can be customized. switches are not made to be adjustable. Inversely proportional to the speed and power.

MECHANICAL DATA

- Operating temperature -20°C~+65°C
- Aluminium outer tube and stroke rod
- Protection IP54 or IP65
- 12 or 24 or 36 or 48VDC
- Preset limit switches
- Powder metal gears
- Aluminium alloy housing
- Low price
- Robust

FORCE DATA

- Max load 1200N
- Duty cycle 20% (High-speed linear 10%)
- Max static force 2300N
- Life time 50 000 complete cycles

DIMENSIONAL DRAWING

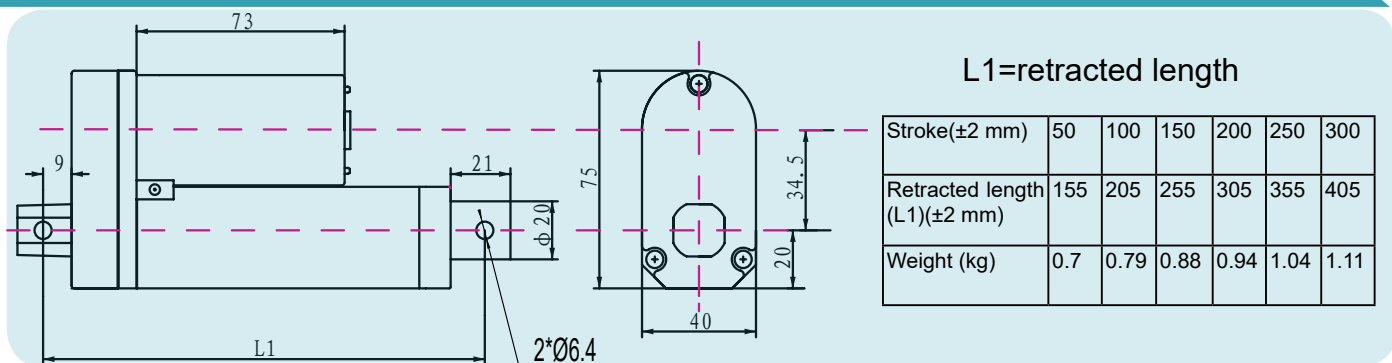

PERFORMANCE DIAGRAMS

Note: The ambient temperature of the test current is 20°C

Ratio	Screw	0 load speed	load speed	max push	max pull	static load	0 load current	load current	0 load current	load current	0 load current	load current	0 load current	load current
		MM/S	MM/S	force N	force N	N	12V	12V	24V	24V	36V	36V	48V	48V
1:10	1.75	10	7	600	450	1200	0.8	3	0.4	1.5	0.3	1	0.2	0.75
	3.175	20	15	400	300	1000	0.8	3	0.4	1.5	0.3	1	0.2	0.75
	5	30	24	200	150	600	0.8	3	0.4	1.5	0.3	1	0.2	0.75
	6	40	30	120	100	400	0.8	3	0.4	1.5	0.3	1	0.2	0.75
	7.5	50	40	100	80	300	0.8	3	0.4	1.5	0.3	1	0.2	0.75
	9	60	45	80	50	200	0.8	3	0.4	1.5	0.3	1	0.2	0.75
1:20	1.75	5	3.2	900	800	2300	0.8	3	0.4	1.5	0.3	1	0.2	0.75
	3.175	10	6.5	750	600	2000	0.8	3	0.4	1.5	0.3	1	0.2	0.75
	5	15	9	600	500	700	0.8	3	0.4	1.5	0.3	1	0.2	0.75
	6	20	13	450	400	600	0.8	3	0.4	1.5	0.3	1	0.2	0.75
	7.5	25	17	350	300	400	0.8	3	0.4	1.5	0.3	1	0.2	0.75
	9	30	21	300	250	320	0.8	3	0.4	1.5	0.3	1	0.2	0.75
1:30	1.75	3	2.2	1200	1000	2300	0.8	3	0.4	1.5	0.3	1	0.2	0.75
	3.175	6	4	900	800	2000	0.8	3	0.4	1.5	0.3	1	0.2	0.75
	5	10	6	800	750	700	0.8	3	0.4	1.5	0.3	1	0.2	0.75
	6	13	7	750	600	600	0.8	3	0.4	1.5	0.3	1	0.2	0.75
	7.5	16	10	700	600	400	0.8	3	0.4	1.5	0.3	1	0.2	0.75
	9	20	12	600	500	320	0.8	3	0.4	1.5	0.3	1	0.2	0.75
	12	26	16	450	400	200	1	3	0.5	1.5	0.3	1	0.2	0.75

HOW TO ORDER

MANAK - LAB25 - 10 . 5 . 100 - 24 - MR

Company	Type	Stroke(cm) 5...30cm	Speed(mm/s) 5...40mm/s	Load(Kgf) 20...100Kgf	Voltage(V DC) 12...48V DC	Special requirements M: Internal micro switch R: anti-rotation
---------	------	------------------------	---------------------------	--------------------------	------------------------------	--

