

TA31

series

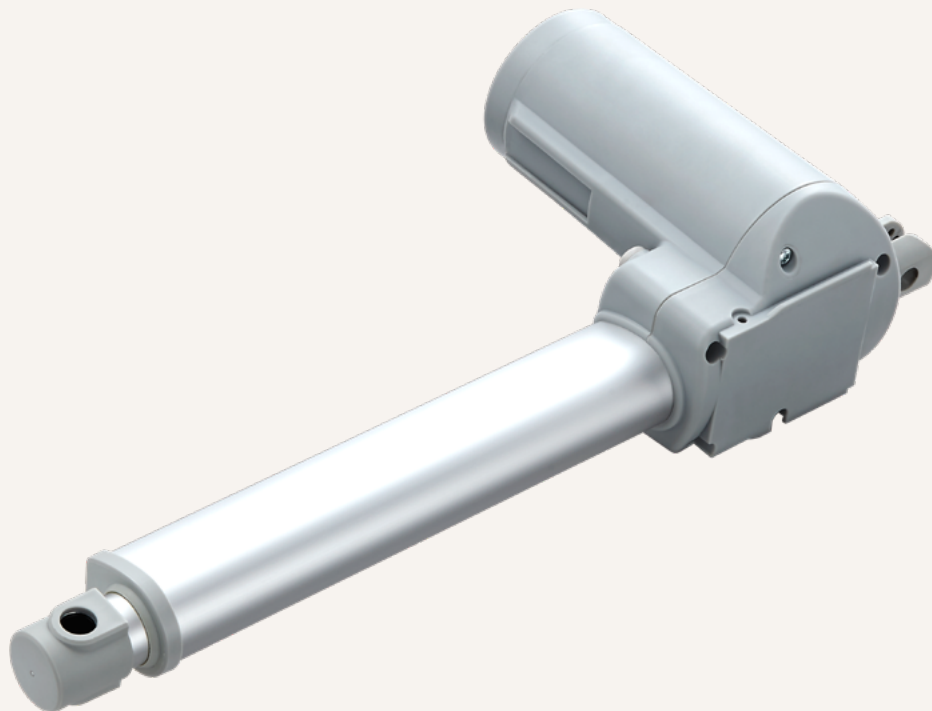

Product Segments

• Care Motion

The TA31 is one of our great medical grade linear actuators. It can lift up to 8000N and its IP rating is up to IP66W. The TA31 is a high quality solution for medical applications such as medical beds, medical chairs, or home care options.

General Features

Max. load	8,000N (push); 3,000N (pull)
Max. speed at max. load	3.7mm/s
Max. speed at no load	26.6mm/s
Retracted length	≥ Stroke + 157mm
IP rating	IP66W
Certificate	IEC60601-1, ES60601-1, IEC60601-1-2
Stroke	25~450mm
Output signals	Hall sensors
Options	Safety nut
Voltage	24V DC; 24V DC (PTC); 24V DC (3-brush motor)
Color	Black, grey
Operational temperature range at full performance	+5°C~+45°C
An economic solution with compact installation dimension Suitable for patient hoist application	

TA31 Series

Drawing

Standard Dimensions
(mm)

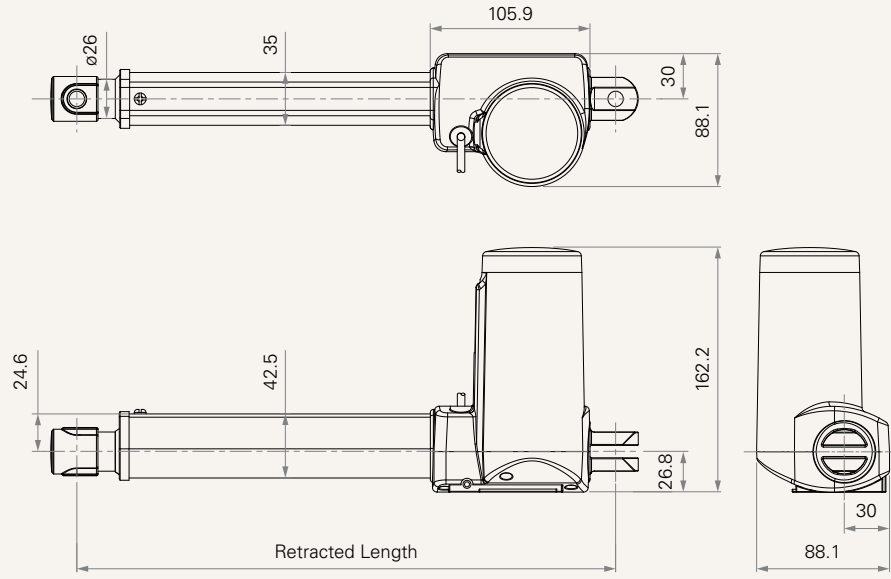

Load and Speed

CODE	Load (N)		Self Locking Force (N)	Typical Current (A)		Typical Speed (mm/s)	
	Push	Pull		No Load 32V DC	With Load 24V DC	No Load 32V DC	With Load 24V DC
Motor Speed (3800RPM, duty cycle 10%)							
B	6000	3000	6000	0.8	3.6	6.0	3.3
C	5000	3000	5000	0.8	3.6	7.8	4.5
D	3500	3000	3500	0.8	3.8	11.7	6.6
E	2000	2000	2000	0.8	3.2	23.4	13.3
F	8000	3000	8000	0.8	4.7	6.0	3.0
G	6000	3000	6000	0.8	4.1	6.9	3.6
Motor Speed (4500RPM, duty cycle 10%)							
H	5000	3000	5000	1.0	3.7	7.7	4.7
J	3500	3000	3500	1.0	4.4	13.4	7.6
K	2000	2000	2000	1.0	3.8	26.6	16.2
L	8000	3000	8000	1.0	5.4	6.6	3.7
M	6000	3000	6000	1.0	4.5	7.6	4.6

Note

- 1 Please refer to the approved drawing for the final authentic value.
- 2 This self-locking force level is reached only when a short circuit is applied on the terminals of the motor. All the control boxes have this feature built-in.
- 3 The current & speed in table are tested with 24V DC motor. With a 12V DC motor, the current is approximately twice the current measured in 24V DC; speed will be similar for both voltages.
- 4 The current & speed in table are tested when the actuator is extending under push load.
- 5 The current & speed in table and diagram are tested with control boxes, and there will be around 10% tolerance depending on different models of the control box. (Under no load condition, the voltage is around 32V DC. At rated load, the voltage output will be around 24V DC)
- 6 Standard stroke: Min. ≥ 25 mm, Max. please refer to below table.

CODE	Load (N)	Max Stroke (mm)
C, D, E	< 6000	450
H, J, K	< 6000	450
B, G, M	= 6000	450
L, F	= 8000	450

Performance Data (24V DC Motor)

Motor Speed (3800RPM, Duty Cycle 10%)

Speed vs. Load

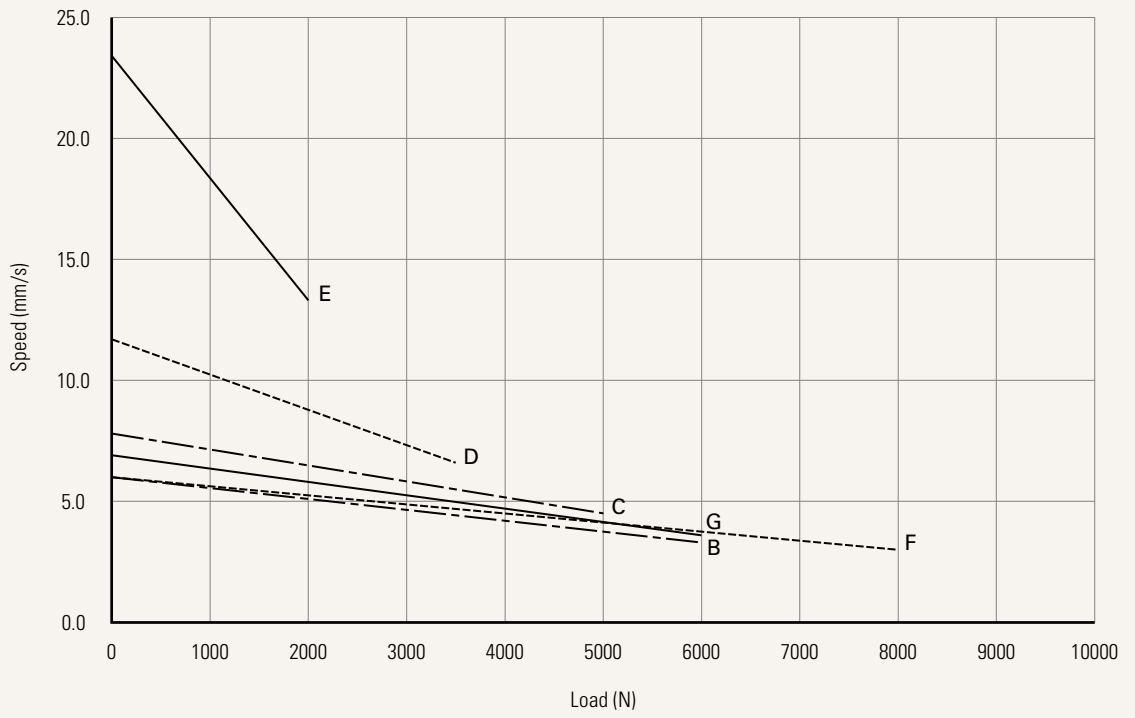

Current vs. Load

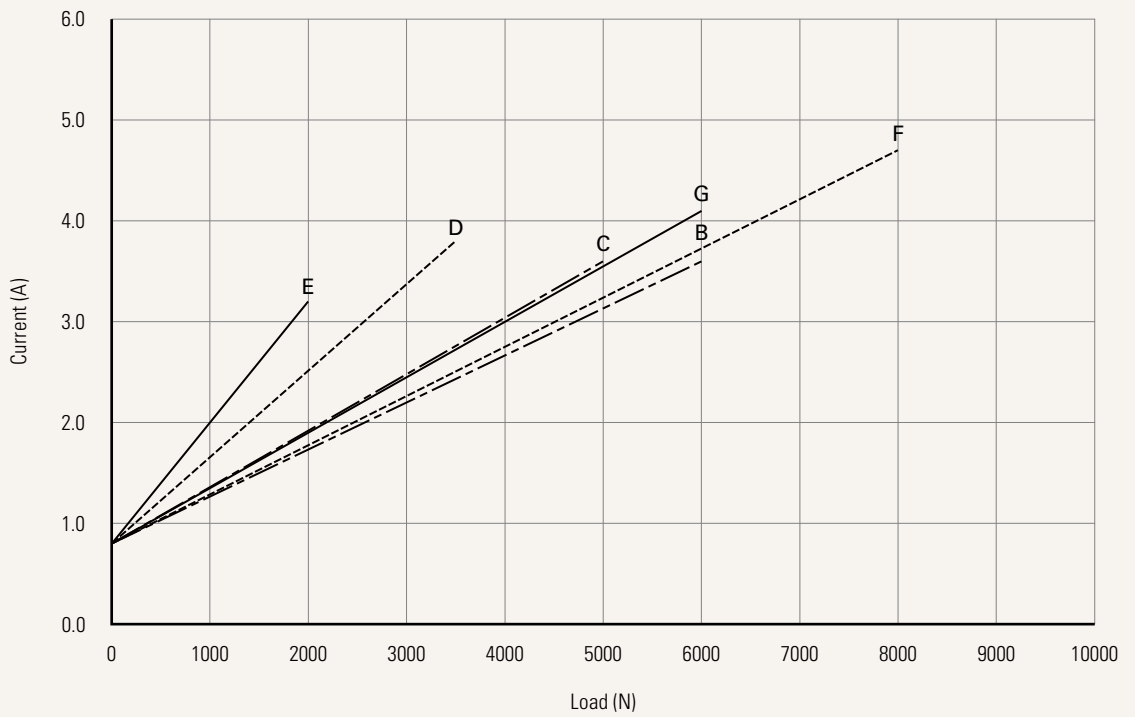

Performance Data (24V DC Motor)

Motor Speed (4500RPM, Duty cycle 10%)

Speed vs. Load

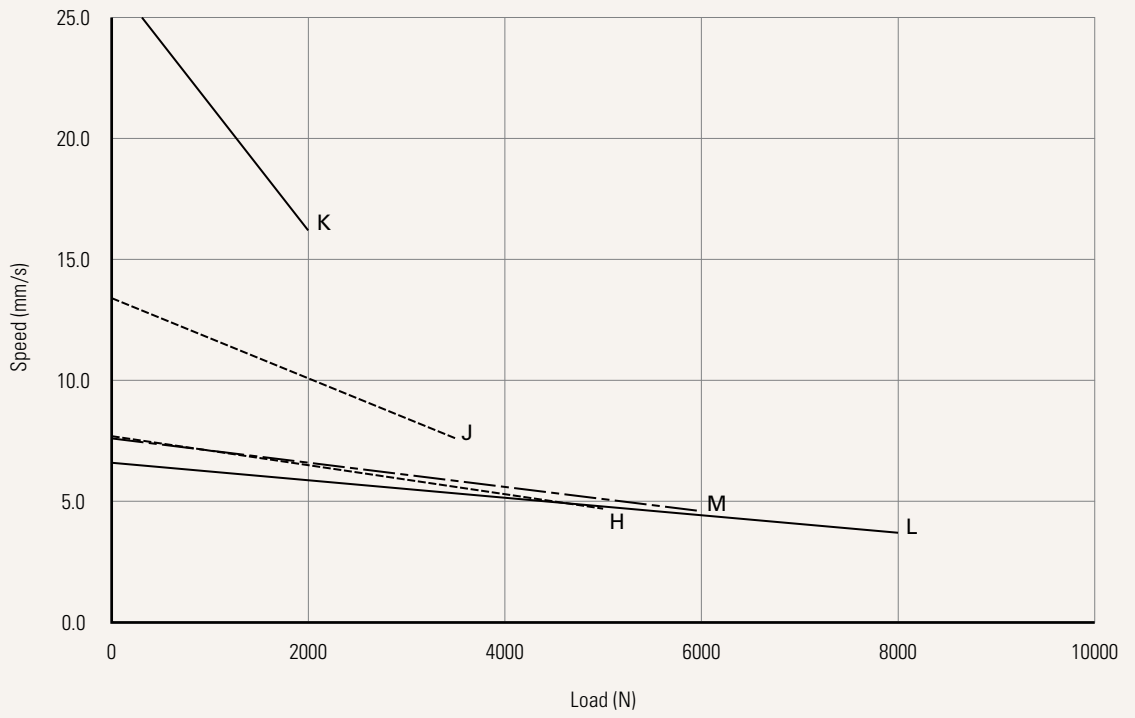

Current vs. Load

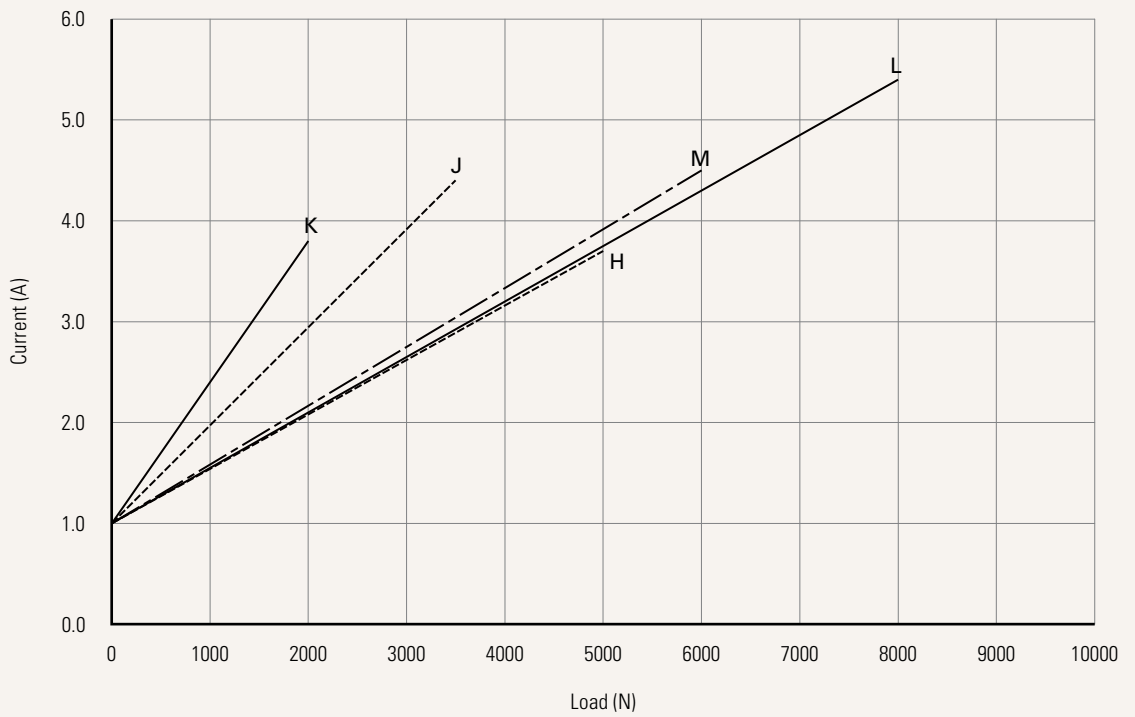

TA31 Ordering Key

TA31

Version: 20250317-Y

Voltage	2 = 24V DC	5 = 24V DC, PTC	C = 24V DC, 3-brush motor	
Load and Speed	See page 3			
Stroke (mm)	See page 3			
Retracted Length (mm)	See page 8			
Rear Attachment (mm) See page 9	2 = Plastic, U clevis, width 8.2, depth 17.0, hole 10.2 (for push < 4000N) 3 = Plastic, U clevis, width 8.2, depth 17.0, hole 12.2 (for push < 4000N) 4 = Aluminum casting, U clevis, width 8.2, depth 17.0, hole 10.2 (for push ≥ 4000N) 5 = Aluminum casting, U clevis, width 8.2, depth 17.0, hole 12.2 (for push ≥ 4000N)			
Front Attachment (mm) See page 9	1 = Punched hole on inner Aluminum tube + plastic cap, without slot, hole 10.2, plastic bush 2 = Punched hole on inner Aluminum tube + plastic cap, without slot, hole 12.2 3 = Plastic, U clevis, width 8.2, depth 20.0, hole 10.2 (for push < 4000N, pull < 2500N) 4 = Plastic, U clevis, width 8.2, depth 20.0, hole 12.2 (for push < 4000N, pull < 2500N) 5 = Punched hole on inner Aluminum tube, without slot, hole 10.2, plastic bush 6 = Punched hole on inner Aluminum tube, without slot, hole 12.2 7 = Aluminum casting, U clevis, width 6.2, depth 17.0, hole 10.2 8 = Aluminum casting, U clevis, width 6.2, depth 17.0, hole 12.2 9 = Aluminum casting, U clevis, width 6.2, depth 17.0, hole 10.2, T bush			
Direction of Rear Attachment (Counterclockwise) See page 10	1 = 0°	3 = 90°		
Color	1 = Black	2 = Pantone 428C		
IP Rating	1 = Without	2 = IP54	3 = IP66	5 = IP66W
Special Functions for Spindle Sub-Assembly	0 = Without (Standard) 1 = Safety nut		2 = Standard push only 3 = Standard push only + safety nut	
Functions for Limit Switches See page 10	1 = Two switches at full retracted / extended positions to cut current 2 = Two switches at full retracted / extended positions to cut current + third one in between to send signal 3 = Two switches at full retracted / extended positions to send signal 4 = Two switches at full retracted / extended positions to send signal + third one in between to send signal 5 = Two switches at full retracted / extended positions to send signal (Operate with control box: TC8, TC10, TC14; compatible with hall sensors)			
Output Signal	0 = Without	2 = Hall sensors * 2		
Connector (mm) See page 11	1 = DIN 6P, 90° plug 2 = Tinned leads 4 = Big 01P, plug C = Y cable (direct cut, water proof, anti-pull) J = Extension cable, not preset on motor cover (cable length 120) R = Extension cable, preset on motor cover (cable length 50)		E = Molex 8P, plug F = DIN 6P, 180° plug G = Audio plug P = Molex 8P, 90° plug, without anti-clip Q = Molex 6P, 90° plug, without anti-clip S = Molex 6P, 180° plug, without anti-clip	
Cable Length (mm)	0 = Straight, 100 1 = Straight, 500 3 = Straight, 1000 5 = Straight, 1500	6 = Straight, 2000 7 = Curly, 200 8 = Curly, 400	B-H = For direct cut system, See page 11 J = Extension cable, not preset on motor cover (cable length 120), See page 11 R = Extension cable, preset on motor cover (cable length 50), See page 11	

TA31 Patient Hoist Ordering Key

TA31

Version: 20250317-Y

Voltage	2 = 24V DC	5 = 24V DC, PTC		
Load and Speed	L = 8000N	M = 6000N		
Stroke (mm)	See page 3			
Retracted Length (mm)	See page 8			
Rear Attachment (mm)	C = Aluminum casting, U clevis, slot 8.2, depth 17.0, hole 10.2, with T-bushing See page 9			
Front Attachment (mm)	F = Aluminum casting, U clevis, slot 8.2, depth 19.0, hole 10.2, with T-bushing, manual release I = Aluminum casting, U clevis, slot 8.2, depth 39.0, hole 10.2, with plastic T-bushing, for manual release G = Aluminum casting, U clevis, slot 8.2, depth 19.0, hole 10.2, with plastic T-bushing, Without press down for manual release See page 9			
Direction of Rear Attachment (Counterclockwise)	1 = 0° See page 10			
Color	1 = Black	2 = Pantone 428C		
IP Rating	1 = Without	2 = IP54	3 = IP66	5 = IP66W
Special Functions for Spindle Sub-Assembly	6 = Mechanical push only + safety nut			
Functions for Limit Switches	1 = Two switches at full retracted / extended positions to cut current See page 10			
Output Signals	0 = Without	2 = Hall sensor * 2		
Connector	1 = DIN 6P, 90° plug F = DIN 6P, 180° plug, for TEC extension cable standard option See page 11	G = Audio plug Q = Molex 6P, 90° plug S = Molex 6P, 180° plug		
Cable Length (mm)	1 = Straight, 500	3 = Straight, 1000		

TA31 Ordering Key Appendix

Retracted Length (mm)

1. Calculate $A+B+C = Y$
2. Retracted length needs to \geq Stroke + Y

A. Front Attach.	Rear Attach.
	General
	2, 3, 4
1, 2, 5, 6	+157
3, 4	+182
7, 8, 9	+172
B, C	+180
F, G (Patient Hoist)	-
I (Patient Hoist)	-

B.			
Stroke (mm)	Load (N)		
	< 6000	= 6000	= 8000
25~150	-	-	-
151~200	-	-	+5
201~250	-	+5	+10
251~300	-	+10	+15
301~350	+5	+15	+20
351~400	+10	+20	+25
401~450	+15	+25	+30

* For stroke over 450mm, please contact our engineers.

C. Load < 5000 (N)		
Front Attach.	Spindle Function	
	0, 1	2, 3
1, 2, 5, 6	-	+5
3, 4	-	+5
7, 8, 9	-	+5
F, G (Patient Hoist)	-	-
I (Patient Hoist)	-	-

C. Load = 5000 / 6000 / 8000 (N)		
Front Attach.	Spindle Function	
	0, 1	2, 3
1, 2, 5, 6	-	+8
3, 4	-	-
7, 8, 9	-	+8
F, G (Patient Hoist)	-	-
I (Patient Hoist)	-	-

TA31 Ordering Key Appendix

Rear Attachment (mm)

2 = Plastic, U clevis, width 8.2, depth 17.0, hole 10.2 (for push < 4000N)

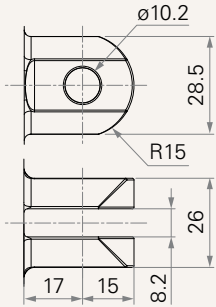

3 = Plastic, U clevis, width 8.2, depth 17.0, hole 12.2 (for push < 4000N)

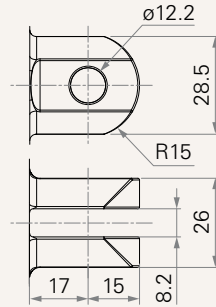

4 = Aluminum casting, U clevis, width 8.2, depth 17.0, hole 10.2 (for push ≥ 4000N)

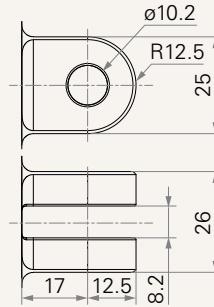

5 = Aluminum casting, U clevis, width 8.2, depth 17.0, hole 12.2 (for push ≥ 4000N)

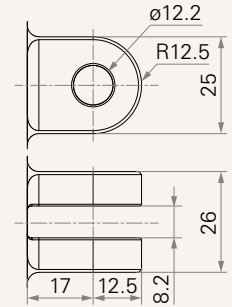

C = Aluminum casting, U clevis, slot 8.2, depth 17.0, hole 10.2, with T-bushing

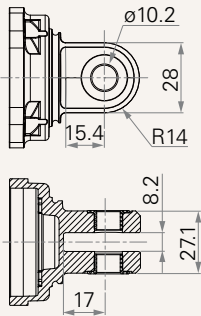

Front Attachment (mm)

1 = Punched hole on inner Aluminum tube + plastic cap, without slot, hole 10.2, plastic bush

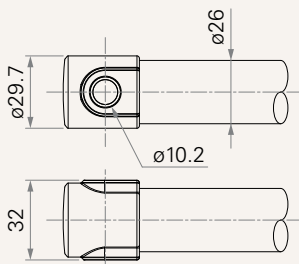

2 = Punched hole on inner Aluminum tube + plastic cap, without slot, hole 12.2

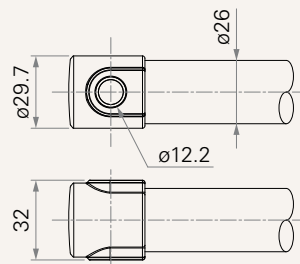

3 = Plastic, U clevis, width 8.2, depth 20.0, hole 10.2 (for push < 4000N, pull < 2500N)

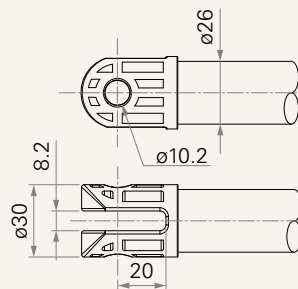

4 = Plastic, U clevis, width 8.2, depth 20.0, hole 12.2 (for push < 4000N, pull < 2500N)

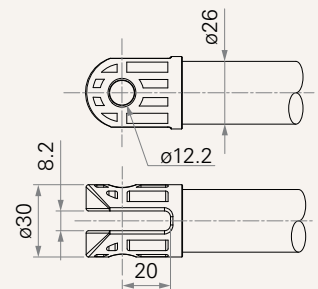

5 = Punched hole on inner Aluminum tube, without slot, hole 10.2, plastic bush

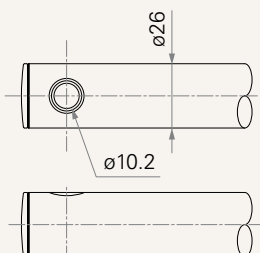

6 = Punched hole on inner Aluminum tube, without slot, hole 12.2

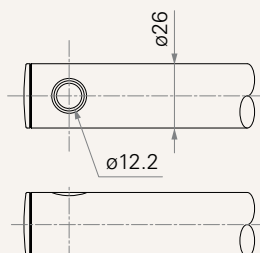

7 = Aluminum casting, U clevis, width 6.2, depth 17.0, hole 10.2

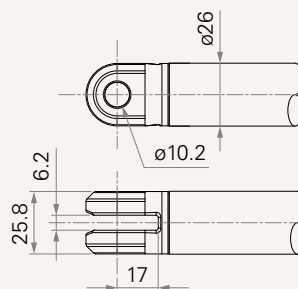

8 = Aluminum casting, U clevis, width 6.2, depth 17.0, hole 12.2

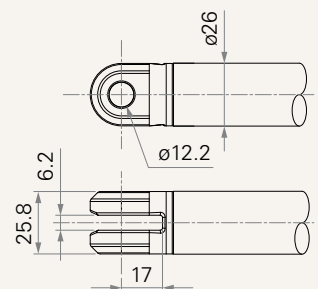

TA31 Ordering Key Appendix

Front Attachment (mm)

9 = Aluminum casting, U clevis, width 6.2, depth 17.0, hole 10.2, T bush

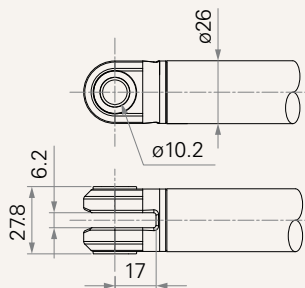

F = Aluminum casting, U clevis, slot 8.2, depth 19.0, hole 10.2, with T-bushing, manual release

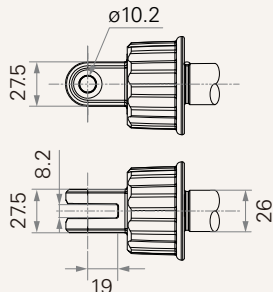

G = Aluminum casting, U clevis, slot 8.2, depth 19.0, hole 10.2, with plastic T-bushing, Without press down for manual release

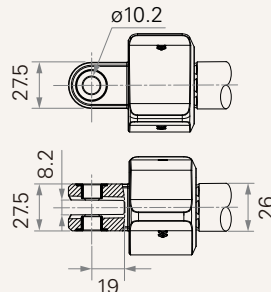

I = Aluminum casting, U clevis, slot 8.2, depth 39.0, hole 10.2, with plastic T-bushing, for manual release

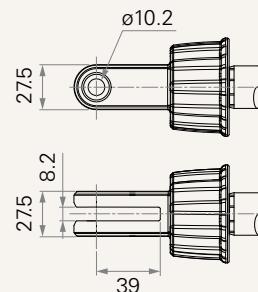

Direction of Rear Attachment (Counterclockwise)

1 = 0°

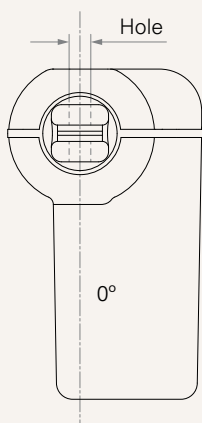

3 = 90°

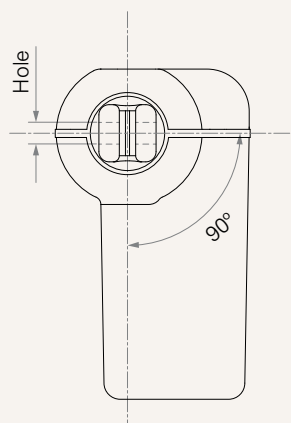

Functions for Limit Switches

Wire Definitions

CODE	Pin					
	1 (Green)	2 (Red)	3 (White)	4 (Black)	5 (Yellow)	6 (Blue)
1	extend (VDC+)	N/A	N/A	N/A	retract (VDC+)	N/A
2	extend (VDC+)	N/A	middle switch pin B	middle switch pin A	retract (VDC+)	N/A
3	extend (VDC+)	common	upper limit switch	N/A	retract (VDC+)	lower limit switch
4	extend (VDC+)	common	upper limit switch	medium limit switch	retract (VDC+)	lower limit switch
5	extend (VDC+)	N/A	upper limit switch	common	retract (VDC+)	lower limit switch

TA31 Ordering Key Appendix

Connector (mm)

1 = DIN 6P, 90° plug

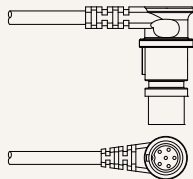

2 = Tinned leads



4 = Big 01P, plug

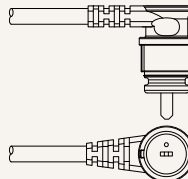

C = Y cable (direct cut, water proof, anti-pull)

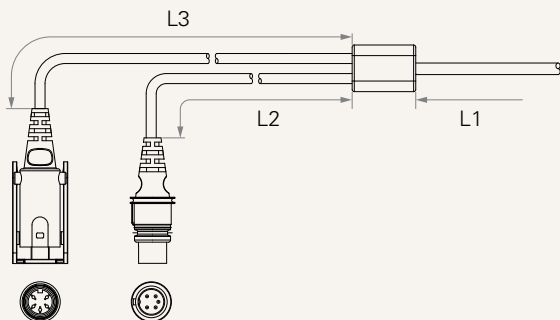

Cable Length for Direct Cut System (mm)

CODE	L1	L2	L3
B	100	100	100
C	100	1000	400
D	100	2700	500
E	1000	100	100
F	100	600	1000
G	1500	1000	1000
H	100	100	1200

J = Extension cable, not preset on motor cover (cable length 120)

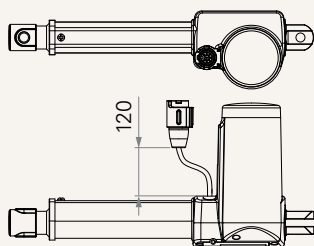

R = Extension cable, preset on motor cover (cable length 50)

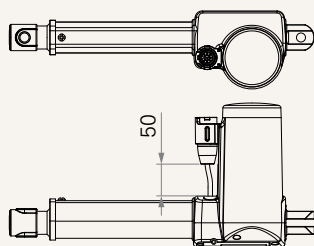

E = Molex 8P, plug

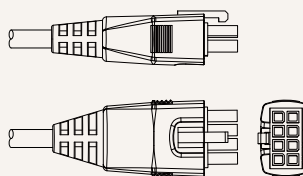

F = DIN 6P, 180° plug



G = Audio plug



P = Molex 8P, 90° plug, without anti-clip

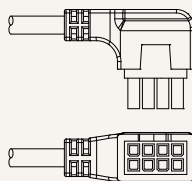

Q = Molex 6P, 90° plug, without anti-clip

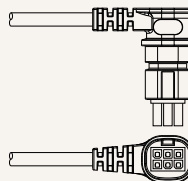

S = Molex 6P, 180° plug, without anti-clip

